



Chipsmall Limited consists of a professional team with an average of over 10 year of expertise in the distribution of electronic components. Based in Hongkong, we have already established firm and mutual-benefit business relationships with customers from,Europe,America and south Asia,supplying obsolete and hard-to-find components to meet their specific needs.

With the principle of "Quality Parts,Customers Priority,Honest Operation,and Considerate Service",our business mainly focus on the distribution of electronic components. Line cards we deal with include Microchip,ALPS,ROHM,Xilinx,Pulse,ON,Everlight and Freescale. Main products comprise IC,Modules,Potentiometer,IC Socket,Relay,Connector.Our parts cover such applications as commercial,industrial, and automotives areas.

We are looking forward to setting up business relationship with you and hope to provide you with the best service and solution. Let us make a better world for our industry!



## Contact us

Tel: +86-755-8981 8866 Fax: +86-755-8427 6832

Email & Skype: info@chipsmall.com Web: www.chipsmall.com

Address: A1208, Overseas Decoration Building, #122 Zhenhua RD., Futian, Shenzhen, China



## High Voltage Protection T/R Switch

### Features

- ▶ Up to  $\pm 100\text{V}$  input voltage protection
- ▶ Low on resistance -  $15\Omega$  typical
- ▶ Fast switching speed
- ▶ Effectively, a simple two terminal device
- ▶ No external supplies needed

### Applications

- ▶ Medical ultrasound imaging
- ▶ NDT applications
- ▶ Fast resettable fuses
- ▶ High side switches
- ▶ Data acquisition

### General Description

The Supertex MD0100 is a high voltage, two terminal, bi-directional, current-limiting protection device. The two terminals are interchangeable. It is designed to protect a low noise receiver from the high voltage transmit pulses in ultrasound applications and is commonly referred to as a T/R (transmit and receive) switch.

The MD0100 can be considered as a normally closed switch with a typical switching resistance of  $15\Omega$  that allows small signals to pass. Once the voltage drop across the two terminals exceeds a nominal value of  $\pm 2.0\text{V}$ , the device will start to turn off. In the off state, the MD0100 can withstand up to  $\pm 100\text{V}$  across its terminals. A small amount of current, typical of  $200\mu\text{A}$ , is allowed to flow through.

The applications for the MD0100 are not limited to just ultrasound. It can also be used for resettable fuses to protect power lines, output short circuit protection, and data acquisition. The MD0100 is available in the SOT-89 package as a single channel device for ease of assembly. It is also available in a  $4.0 \times 4.0\text{mm}$  8-Lead DFN package as a two channel device for high density requirements.

### Typical Application Circuit

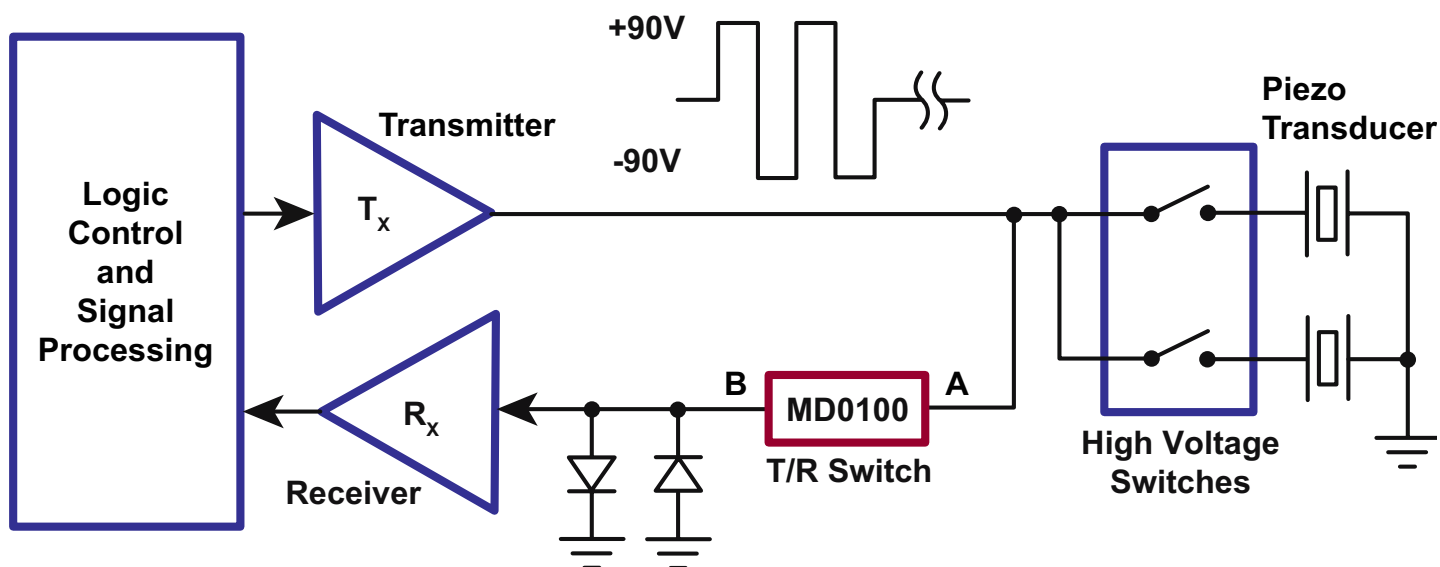

## Ordering Information

Part Number	Package Options	Packing
MD0100DK6-G (Dual Channel)	8-Lead (4x4) DFN	3000/Reel
MD0100N8-G (Single Channel)	3-Lead TO-243AA (SOT-89)	2000/Reel

-G denotes a lead (Pb)-free / RoHS compliant package

## Absolute Maximum Ratings<sup>1</sup>

Parameter	Value
$V_{A-B}$ , differential voltage drop	0 to $\pm 110V$
Maximum junction temperature	+125°C
Storage temperature range	-65°C to 150°C
Power dissipation, 8-Lead DFN <sup>2</sup>	1.1W
Power dissipation, SOT-89 <sup>2</sup>	1.6W

**Notes:**

1. Absolute Maximum Ratings are those values beyond which damage to the device may occur. Functional operation under these conditions is not implied. Continuous operation of the device at the absolute rating level may affect device reliability. All voltages are referenced to device ground.

2. Mounted on FR4 board, 25mm x 25mm x 1.57mm

## Typical Thermal Resistance

Package	$\theta_{ja}$
8-Lead DFN	44°C/W
3-Lead TO-243AA (SOT-89)	133°C/W

## Pin Configuration

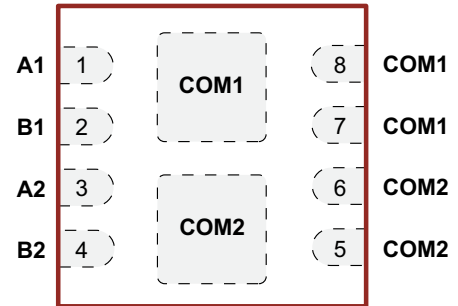

8-Lead DFN  
(top view)  
(Pads are at bottom of device)

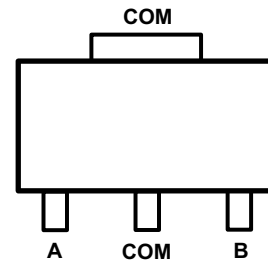

SOT-89

## Product Marking

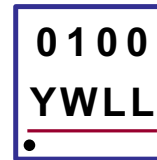

Y = Last Digit of Year Sealed  
W = Code for Week Sealed  
LL = Lot Number  
— = "Green" Packaging

**8-Lead DFN**

Package may or may not include the following marks: Si or

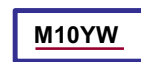

Y = Last Digit of Year Sealed  
W = Code for Week Sealed  
— = "Green" Packaging

**SOT-89**

Package may or may not include the following marks: Si or

## Electrical Characteristics ( $T_j = 25^\circ C$ , unless otherwise specified)

Sym	Parameter	Min	Typ	Max	Units	Conditions
$V_{A-B}$	Max. differential input voltage from A to B	$\pm 100$	-	-	V	$I_{A-B} = \pm 500\mu A$
$R_{SW}$	Switch ON resistance from A to B	-	15	-	$\Omega$	$I_{A-B} = \pm 5.0mA$
$V_{TRIP}$	$V_{A-B}$ trip point to turn off	-	$\pm 1.0$	$\pm 2.0$	V	---
$V_{OFF}$	Switch turn off voltage	-	$\pm 2.0$	-	V	$I_{A-B} = \pm 1.0mA$
$I_{A-B(OFF)}$	Switch off current	-	$\pm 200$	$\pm 300$	$\mu A$	$V_{A-B} = \pm 100V$
$I_{PEAK}$	Peak switching current	-	$\pm 60$	-	mA	See Fig. 8



**Electrical Characteristics** ( $T_J = 25^\circ\text{C}$ , unless otherwise specified)

Sym	Parameter	Min	Typ	Max	Units	Conditions
$T_{OFF}$	Turn off time	-	-	20	ns	See Fig. 2, 3 & 4
$T_{ON}$	Turn on time	-	-	20	ns	See Fig. 5, 6 & 7
$C_{SW(ON)}$	Switch ON capacitance from A to B	-	21	-	pF	SW = ON
$C_{SW(OFF)}$	Switch OFF capacitance from A to B	-	15	-	pF	$V_{SW} = 25\text{V}$
BW	Small signal bandwidth	-	100	-	MHz	$R_{LOAD} = 50\Omega$
$T_J$	Operating junction temperature	-40	-	+125	$^\circ\text{C}$	---

**Block Diagram**

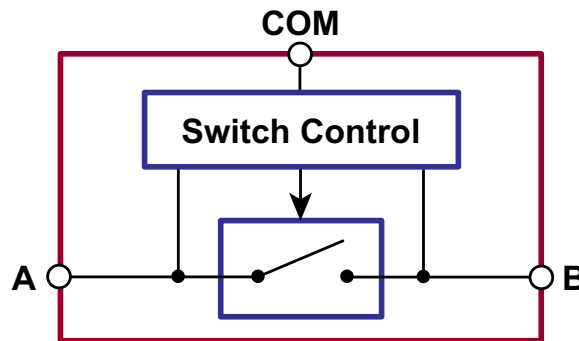

**Typical I-V Characteristics**

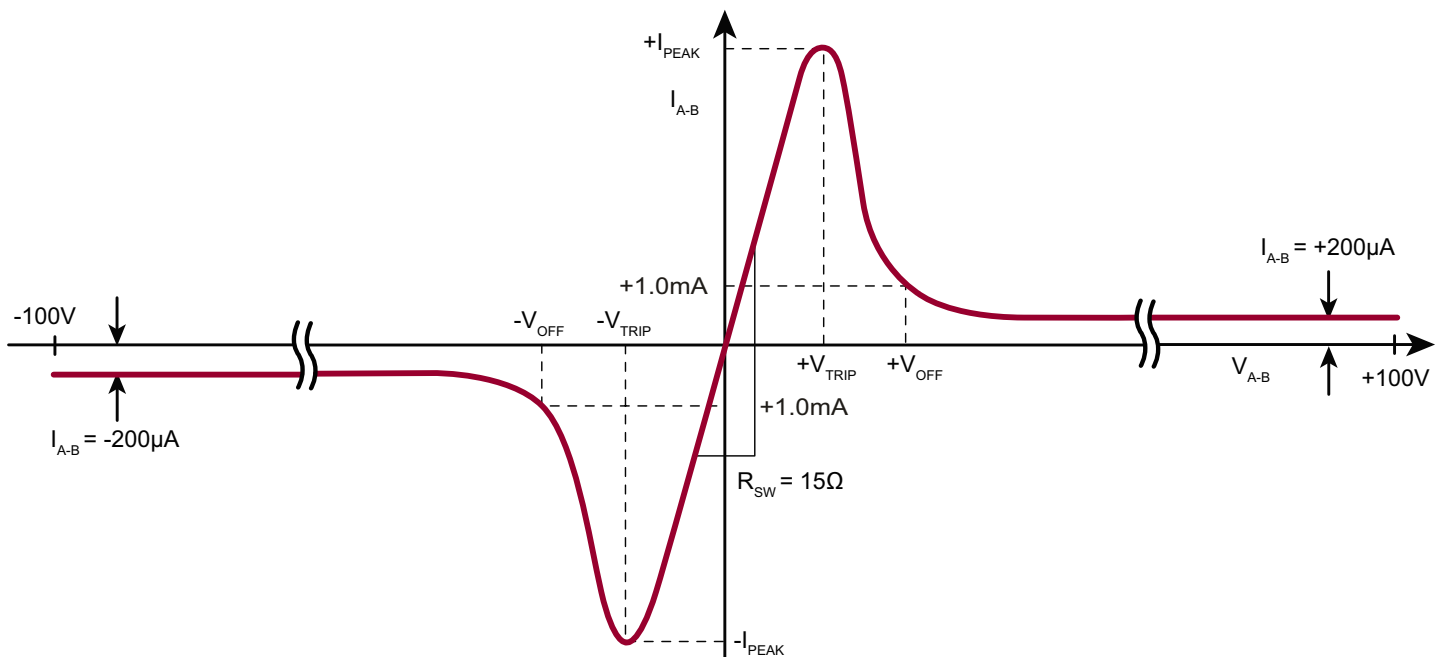

## Functional Description

The Supertex MD0100 can be considered as a normally closed switch controlled by a switch control. (Refer to the block diagram.) The switch control monitors the voltage drop across terminals A and B. If the voltage difference is greater than  $\pm 2.0V$ , the T/R switch will start to open. Once in the open state, there is a small amount of current flowing through the T/R switch, 200uA, to detect if the high voltage is still present or not. The T/R switch will not close until the voltage across terminal A and B drops within  $\pm 2.0V$ . A pair of back-to-back diodes from the receive side of the switch to ground are needed to complete the circuit and to allow the initial peak current (about 60mA) to flow through the switch so it can drop  $\pm 2.0V$ . If the diodes are not present, then there is no current path and the voltage drop across terminal A and B will be less than  $\pm 2.0V$ , so the switch will remain in the closed position.

The other purpose of the diode is to clamp voltage spikes to  $\pm 0.7V$  during transmit cycle. A low voltage diode, for example 1.0V diode, is sufficient since it will only see  $\pm 0.7V$ . A BAV99T dual diode from Diodes, Inc. was used in our test circuit.

## On Resistance

When the voltage across terminals A and B is within  $\pm 2.0V$ , the switch is in the receive mode, and the  $R_{ON}$  is typically 15 $\Omega$ . Once the voltage across terminals A and B is greater than  $\pm 2.0V$ , the switch is in the transmit mode and blocks the high voltage pulses from passing through to the receiver and damaging it.

The MD0100 does not require any power supply. There are only two active pins; one connects to the transmitter side and the other one connects to the receiver side.

## Switch Capacitance

The typical switch ON capacitance ( $C_{SW(ON)}$ ) is 21pF. This is measured from A to B or B to A when the switch is ON.

The switch OFF capacitance is a function of the voltage across the T/R switch. The  $C_{SW(OFF)}$  is about 12 to 19 pF for 10V to 100V of the transmit voltage. Please see Figure 1 for the C-V curve of the  $C_{SW(OFF)}$ .

Figure 1:  $C_{SW(OFF)}$  vs  $V_{SW}$

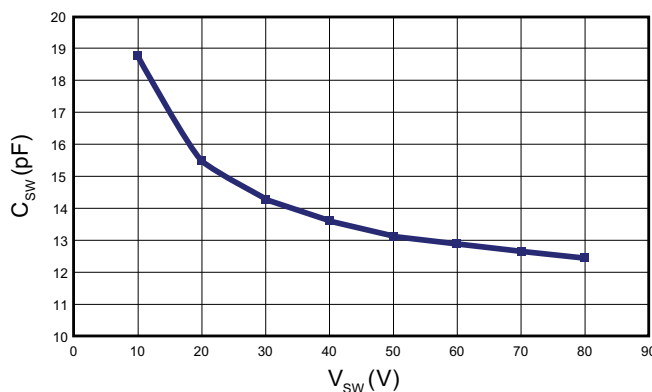

## $T_{ON}$ and $T_{OFF}$ Time

The  $T_{ON}$  and  $T_{OFF}$  of the MD0100 are less than 20ns, which provide a fast switch between the transmit mode and the receive mode. The  $T_{ON}$  and  $T_{OFF}$  are input rise/fall time dependent. The MD0100 turns ON and OFF faster when the rise and fall times of the transmit pulse are faster. On the other hand, the switch turns ON and OFF slower if the rise and fall times of the transmit pulse are slower. The  $T_{OFF}$  and  $T_{ON}$  set up are shown in Figure 2 and Figure 5 respectively.

Figure 2: Test set up for  $T_{OFF}$

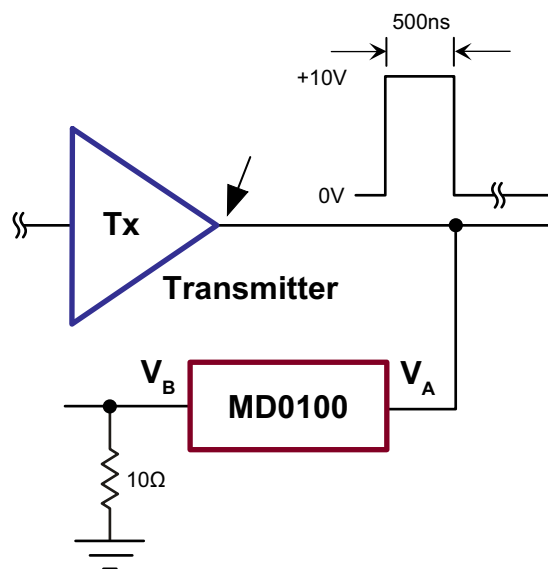

Figure 3:  $T_{OFF}$  Timing Diagram

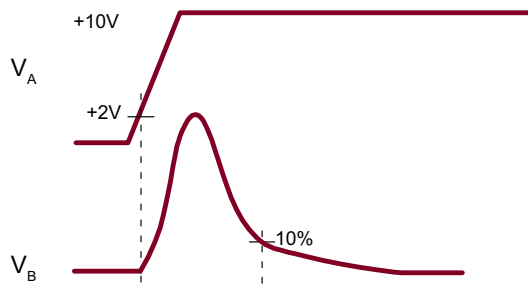

Figure 6:  $T_{ON}$  Timing Diagram

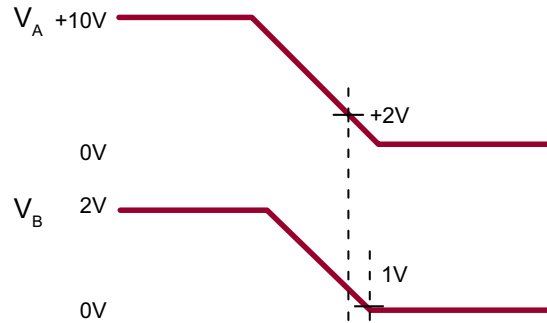

Figure 4:  $T_{OFF}$  at  $V_A = 10V$

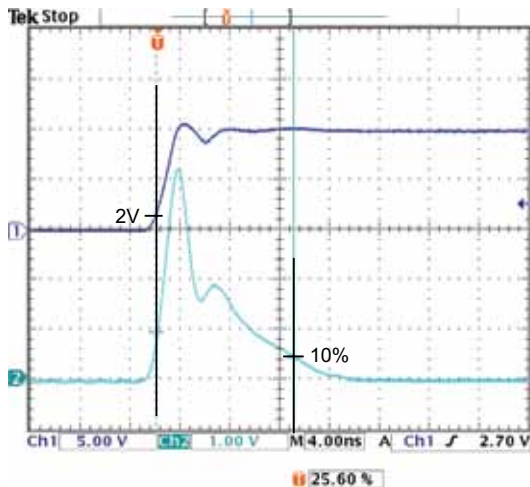

Figure 4 shows the actual waveform and measurement of the  $T_{OFF}$ .  $T_{OFF}$  is measured from 2V of the  $V_A$  to 10% of the  $V_B$ . From the above waveform, the  $T_{OFF}$  is 11ns.

Figure 7:  $T_{ON}$  at  $V_A = 10V$

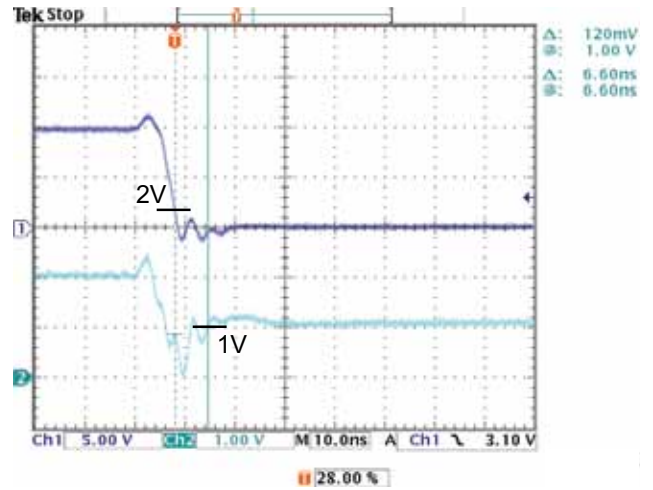

Figure 7 shows the actual waveform and measurement of the  $T_{ON}$ . The  $T_{ON}$  is measured from 2V of the  $V_A$  to 1V of the  $V_B$ . From the above waveform, the  $T_{ON}$  is 6.6ns.

Figure 5: Test Set Up for  $T_{ON}$

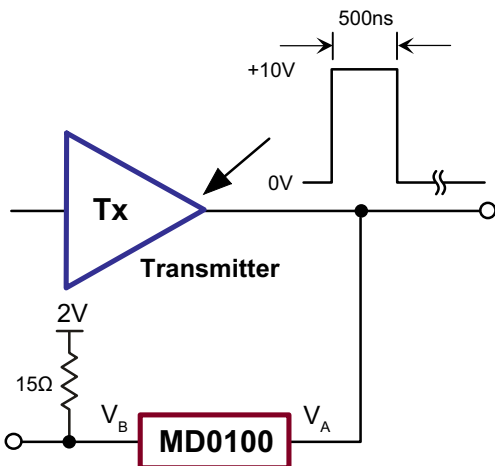

Figure 8: Test Set Up for  $I_{PEAK}$

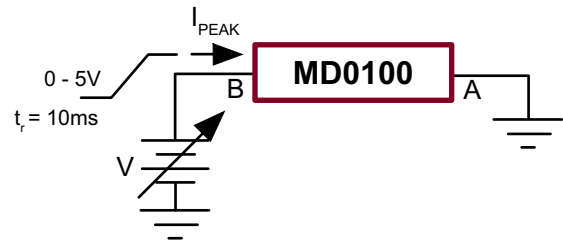

Figure 9: Typical Application Circuit

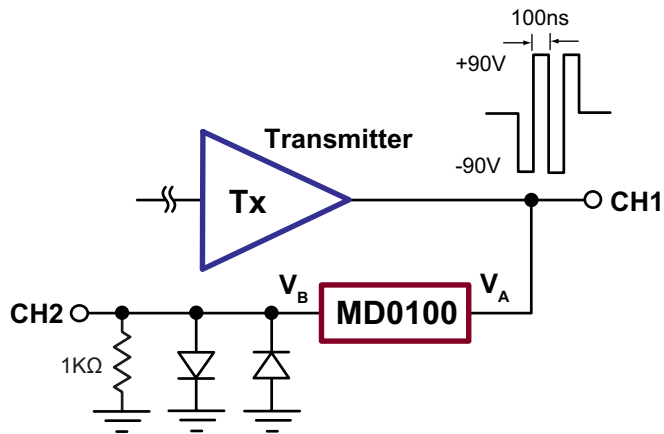

Figure 10: Typical Waveform

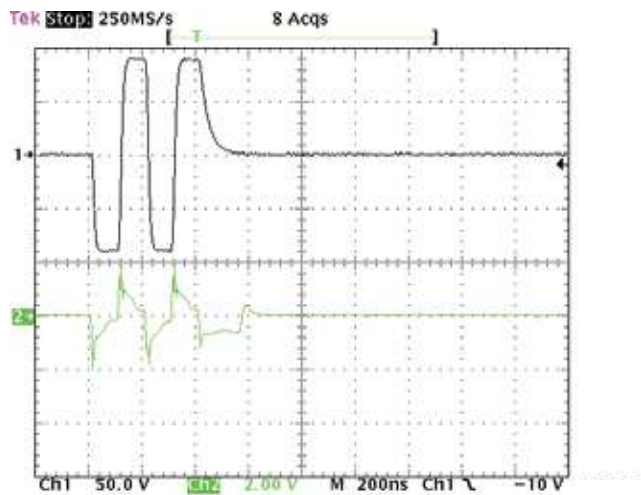

Figure 10 shows the waveforms of  $V_A$  and  $V_B$  of the test circuit shown in Figure 9. There is a small bump of about 0.5V at the tail of the  $V_B$  signal because the transmit signal falls into the  $\pm 2.0V$  range, and the MD0100 turns back ON again. Figure 11 shows a magnified view of the  $V_A$ .

Figure 11: Typical Waveform

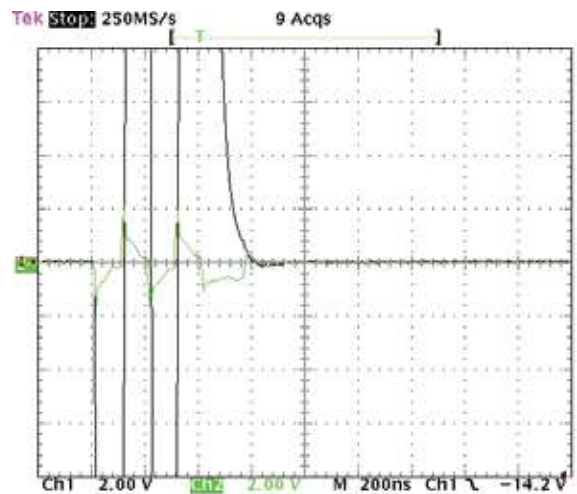

Figure 11 shows  $V_A$  and  $V_B$  in the same voltage scale, 2.0V/DIV.

**Pin Description (8-Lead DFN)**

Pin	Name	Description
1	A1	Switch terminal A1
2	B1	Switch terminal B1
3	A2	Switch terminal A2
4	B2	Switch terminal B2
5	COM2	Leave floating
6	COM2	
7	COM1	Leave floating
8	COM1	
Heat Slug 1	COM1	Leave floating
Heat Slug 2	COM2	Leave floating

**Pin Description (SOT-89)**

Name	Description
A	Switch terminal A
COM	Leave floating
B	Switch terminal B



# 8-Lead DFN Package Outline (K6)

4.00x4.00mm body, 1.00mm height (max), 1.00mm pitch (dual pad)

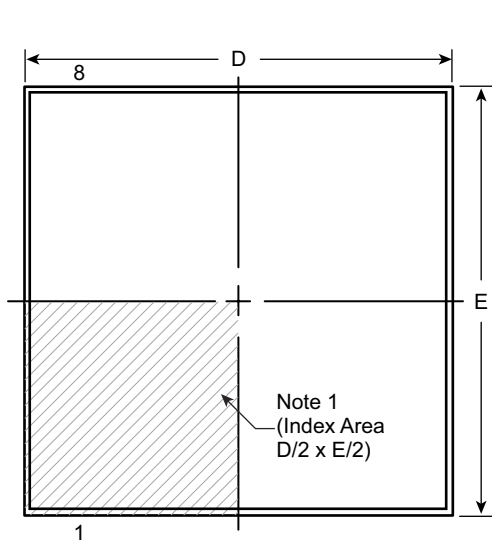

**Top View**

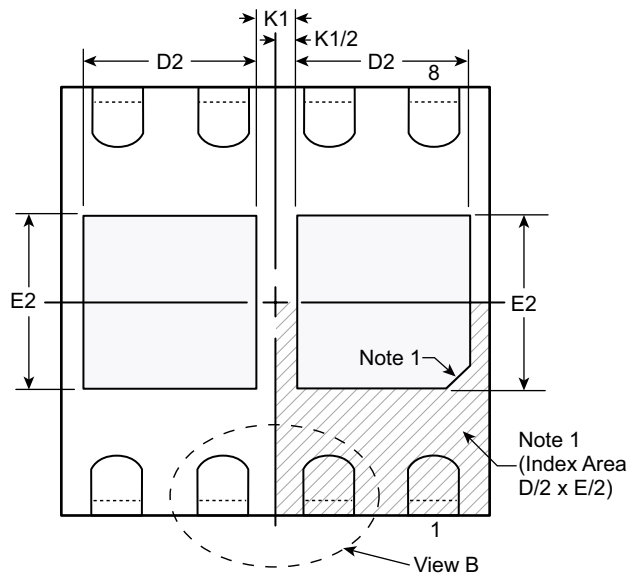

**Bottom View**

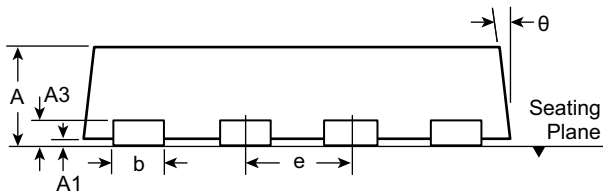

**Side View**

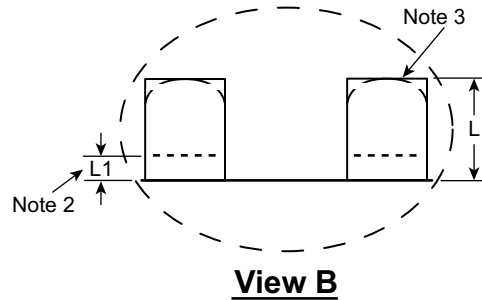

**View B**

**Notes:**

1. A Pin 1 identifier must be located in the index area indicated. The Pin 1 identifier can be: a molded mark/identifier; an embedded metal marker; or a printed indicator.
2. Depending on the method of manufacturing, a maximum of 0.15mm pullback (L1) may be present.
3. The inner tip of the lead may be either rounded or square.

Symbol	A	A1	A3	b	D	D2	E	E2	e	K1	L	L1	θ	
Dimension (mm)	MIN	0.80	0.00	0.20 REF	0.25	3.90	1.35	3.90	1.35	1.00 BSC	0.50 REF	0.40	0.00	0°
	NOM	0.90	-		0.30	4.00	1.45	4.00	1.45			0.50	-	-
	MAX	1.00	0.05		0.35	4.10	1.55	4.10	1.55			0.60	0.15	14°

Drawings not to scale

Supertex Doc. #: DSPD-8DFNK64x4P100, Version C010813

### 3-Lead TO-243AA (SOT-89) Package Outline (N8)

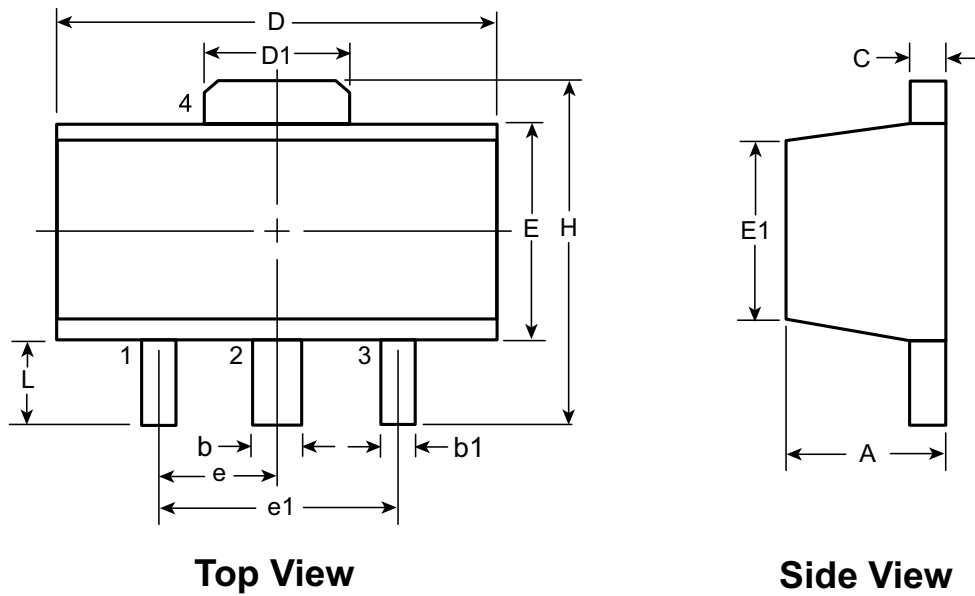

Symbol	A	b	b1	C	D	D1	E	E1	e	e1	H	L		
Dimensions (mm)	MIN	1.40	0.44	0.36	0.35	4.40	1.62	2.29	2.00 <sup>†</sup>	1.50 BSC	3.00 BSC	3.94	0.73 <sup>†</sup>	
	NOM	-	-	-	-	-	-	-	-			-	-	-
	MAX	1.60	0.56	0.48	0.44	4.60	1.83	2.60	2.29			4.25	1.20	

JEDEC Registration TO-243, Variation AA, Issue C, July 1986.

<sup>†</sup> This dimension differs from the JEDEC drawing

**Drawings not to scale.**

**Supertex Doc. #:** DSPD-3TO243AAN8, Version F111010.

(The package drawing(s) in this data sheet may not reflect the most current specifications. For the latest package outline information go to <http://www.supertex.com/packaging.html>.)

**Supertex inc.** does not recommend the use of its products in life support applications, and will not knowingly sell them for use in such applications unless it receives an adequate "product liability indemnification insurance agreement." **Supertex inc.** does not assume responsibility for use of devices described, and limits its liability to the replacement of the devices determined defective due to workmanship. No responsibility is assumed for possible omissions and inaccuracies. Circuitry and specifications are subject to change without notice. For the latest product specifications refer to the **Supertex inc.** (website: <http://www.supertex.com>)