



Chipsmall Limited consists of a professional team with an average of over 10 year of expertise in the distribution of electronic components. Based in Hongkong, we have already established firm and mutual-benefit business relationships with customers from,Europe,America and south Asia,supplying obsolete and hard-to-find components to meet their specific needs.

With the principle of "Quality Parts,Customers Priority,Honest Operation,and Considerate Service",our business mainly focus on the distribution of electronic components. Line cards we deal with include Microchip,ALPS,ROHM,Xilinx,Pulse,ON,Everlight and Freescale. Main products comprise IC,Modules,Potentiometer,IC Socket,Relay,Connector.Our parts cover such applications as commercial,industrial, and automotives areas.

We are looking forward to setting up business relationship with you and hope to provide you with the best service and solution. Let us make a better world for our industry!



## Contact us

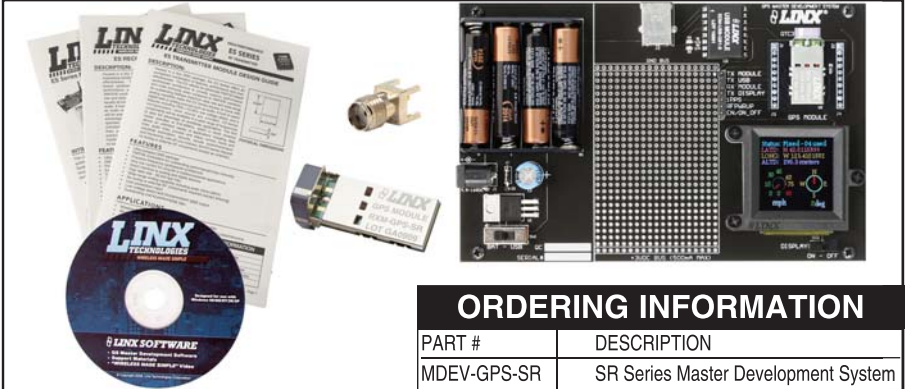
Tel: +86-755-8981 8866 Fax: +86-755-8427 6832

Email & Skype: info@chipsmall.com Web: www.chipsmall.com

Address: A1208, Overseas Decoration Building, #122 Zhenhua RD., Futian, Shenzhen, China



## SR Series Master Development System User's Guide



## INTRODUCTION

The Linx SR Series RF modules offer a simple, efficient, and cost-effective method of adding GPS capabilities to any product. The Master Development System is intended to give a designer all the tools necessary to correctly incorporate the SR Series into an end product. The development boards themselves serve several important functions:

- **Rapid Module Evaluation** - The boards allow the performance of the Linx SR Series modules to be evaluated quickly in a user's environment.
- **Design Benchmark** - During the design process of your product, the boards provide a known benchmark against which the performance of your own design may be judged.
- **Application Development** - An on-board prototyping area is provided to allow a designer to develop applications directly on the development board. All signal lines are available on a header for easy connection to the designer's circuits.

The Master Development System includes 1 assembled development board, 2 SR Series receivers\*, 4 AAA batteries, and full documentation.

*\*One part is soldered to the board, one extra is for use on your first prototype board.*

# SR SERIES RECEIVER DEVELOPMENT BOARD

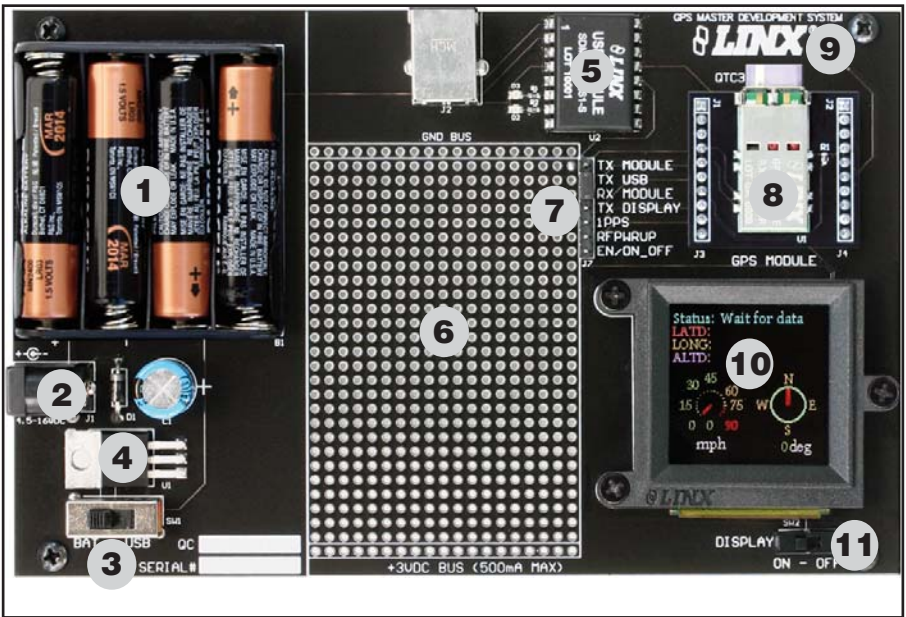


Figure 1: SR Series Receiver Development Board

1. Four AAA Batteries
2. DC Power Jack
3. Power Switch
4. Voltage Regulator
5. USB Interface Module
6. Prototype Area
7. Break-Out Header
8. SR Series Receiver Daughter Board
9. CR2032 Backup Battery (on the back)
10. OLED Display
11. OLED Display Power Switch

## TROUBLESHOOTING

If the board fails to work out of the box, then try the following:

- Check the batteries to make sure they are not dead.
- Check to make sure that the power switch is in the correct position.
- Make sure that the jumper is set correctly.

If all of these appear to be in order, please call 800-736-6677 or e-mail [techsupport@linxtechnologies.com](mailto:techsupport@linxtechnologies.com) for technical support.

# INITIAL SETUP

Unpack the development system and install the AAA and coin-cell batteries. The power switch can select between the battery pack / DC power jack or USB if the board is plugged into a USB bus. To use the display, turn the OLED display power switch on. The development board is now ready for use. After turning on the power, the module will determine its current position. Please note, the time required for an initial fix or after long periods of storage will be considerably greater than in subsequent operation. Please refer to the module's data guide for complete information regarding time-to-first-fix (TTFF). To protect the display and extend its life, turn the display off before turning the board off.

# THE PROTOTYPING AREA

In addition to its evaluation functions, the board may also be used for actual product development. It features a prototyping area to facilitate the addition of application-specific circuitry. The prototyping area contains a large area of plated through-holes so that external circuitry can be placed on the board. The holes are set at 0.100" on center with a 0.040" diameter, making it easy to add most industry-standard SIP and DIP packages to the board.

External circuitry can be easily interfaced with the SR receiver through the breakout header (J7) to the right of the prototyping area. A jumper shunt has been provided to control the routing of data into the GPS module. By default the jumper is set for operation with the on-board USB module. When communicating with the GPS module using your own components this jumper shunt should be removed. At the bottom of the prototyping area is a row connected to the 3V power supply and at the top is a row connected to ground.

**NOTE:** The on-board 3-volt regulator has approximately 300mA of headroom available for additional circuitry. If added circuitry requires a higher current, the user must add an additional regulator to the prototype area or power the board from an external supply.

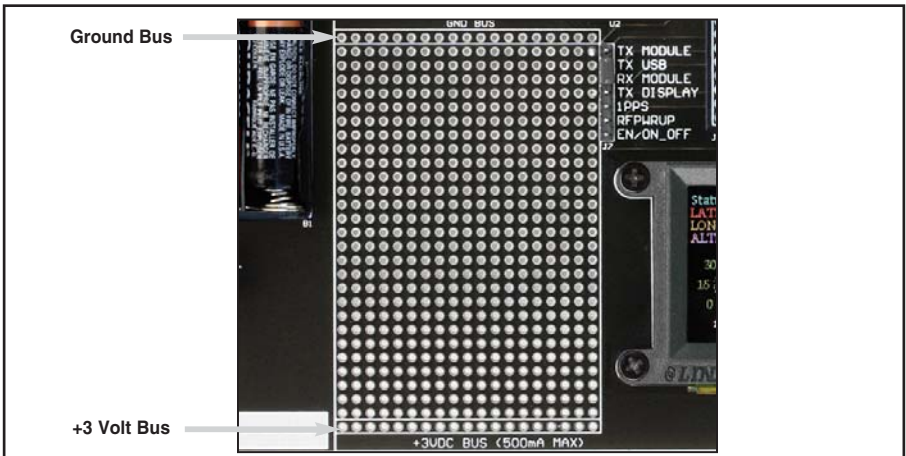


Figure 2: The Development Board Prototyping Area

## THE GPS RECEIVER SECTION

The receiver module is mounted on a daughter board which plugs into headers on the main development board.

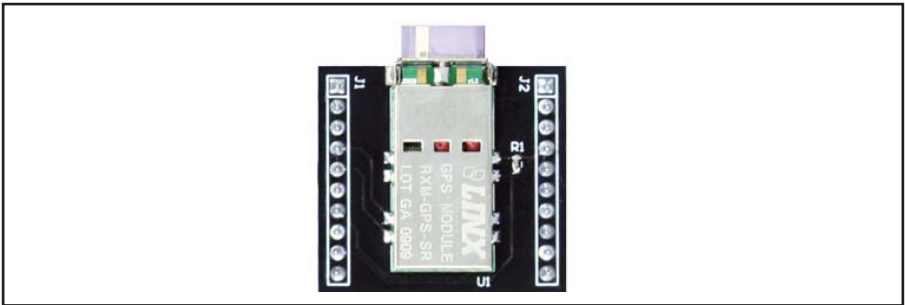


Figure 3: The Development Board GPS Receiver Section

On the bottom of the main board is a CR2032 coin cell battery that provides power to the RTC and SRAM when the receiver is powered down. This allows the receiver to start up and obtain a position fix faster. This cell will provide about two years of operation.

## THE USB SECTION

The development board features a Linx QS Series USB module for interface to a PC. This allows the board to be used with the supplied development software or with custom software developed by the user.

Drivers for the USB module are included on the software CD in the kit or may be downloaded from [www.linxtechnologies.com](http://www.linxtechnologies.com). Additional information on using the QS Series USB module can also be found on the website.

The USB connection also allows the board to be powered by the USB bus instead of batteries. This can be convenient during development to eliminate the need for frequent battery replacement.

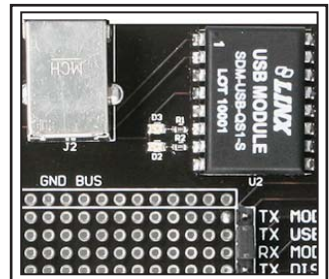


Figure 4: The USB Section

Output data from the GPS module is connected directly to the USB module, but data into the GPS module is split. This is to prevent data collisions between the USB module and any circuitry added to the prototyping area. To route serial data from the USB module to the serial data receive line on the GPS module, use the supplied jumper to connect the TX USB and RX MODULE lines on the breakout header as shown in the adjoining diagram. Remove this jumper for use with external circuitry. The pin marked TX DISPLAY is for Linx use and should be left unconnected.

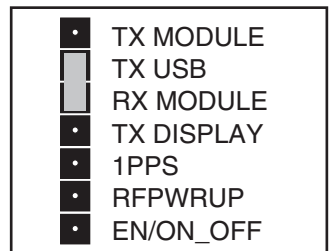


Figure 5: Jumper Configuration

# THE DISPLAY SECTION

The SR Series Master Development System features an OLED screen that displays the navigation information from the GPS module. This allows the development board to act as a stand-alone evaluation system without the need for any additional software.



Figure 6: The Development Board Display Section

The display is driven by an on-board microcontroller located under the display. Data from the GPS module is connected directly to this microcontroller. The microcontroller receives data at the receiver's default 9,600bps. **If the receiver's baud rate is changed, it will not be able to communicate with the microcontroller.**

The display and microcontroller pull about 100mA when fully powered, so a power switch is supplied to deactivate the display area when not in use, saving battery life. To protect the display and extend its life, be sure to turn the display section off before turning off the main power to the board.

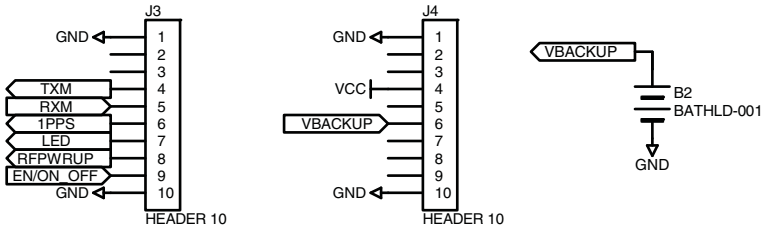
# MASTER DEVELOPMENT SOFTWARE

The development system is supplied with Windows-based software that communicates with the development board through the USB module. This software displays the information from the GPS module in the different NMEA formats and the satellite information, signal strength, and positions are displayed graphically. If the PC is connected to the internet, the software plots the current location on Google Maps. Full details are in the software's User's Guide.

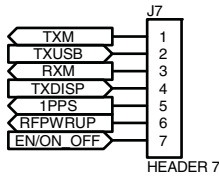


Figure 7: Master Development Software

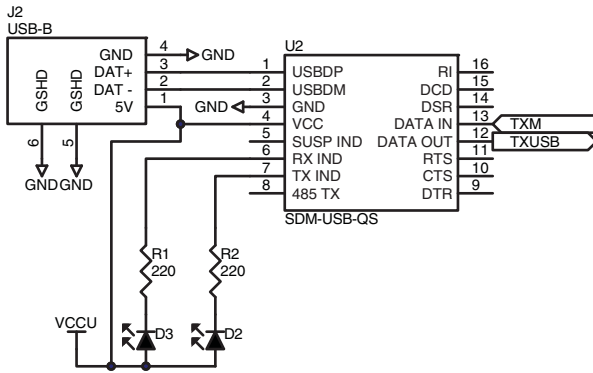
## RECEIVER SECTION



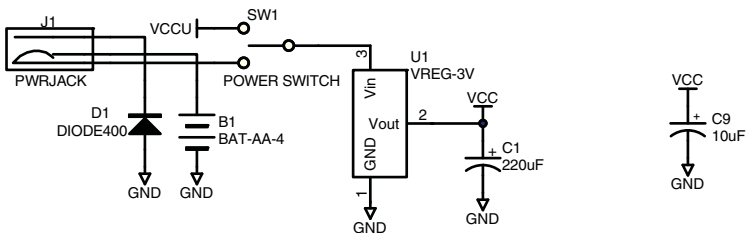
## HEADER SECTION



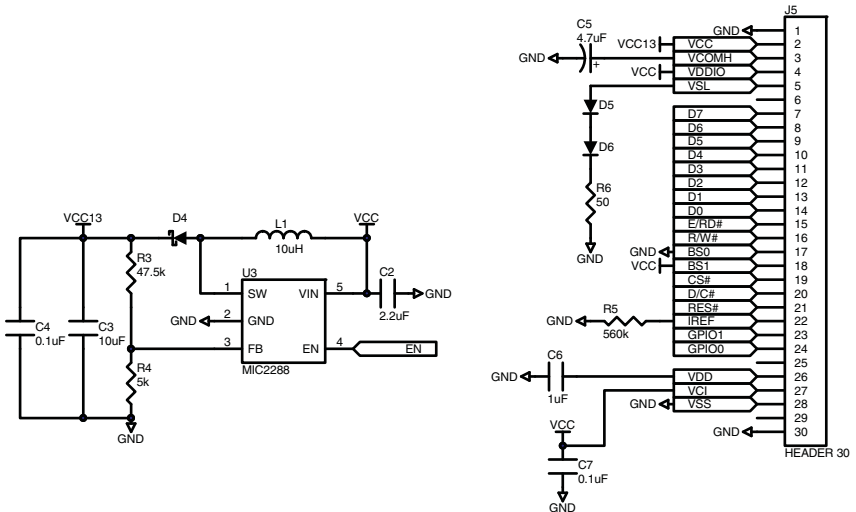
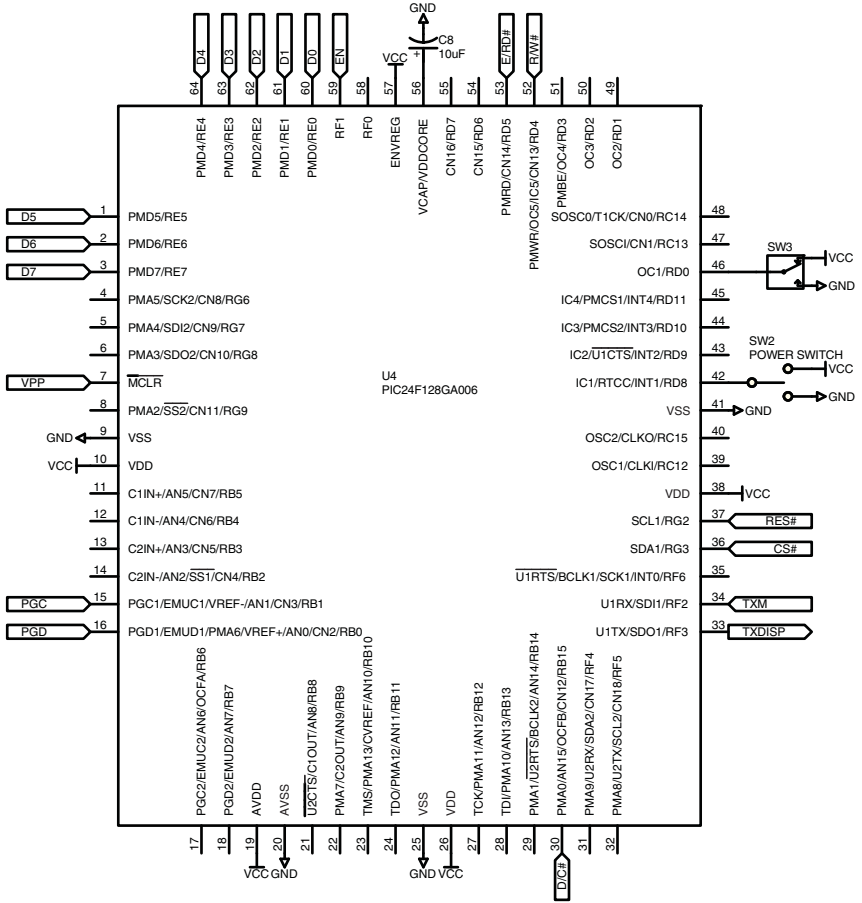
## USB SECTION



## POWER SUPPLY SECTION



# DISPLAY SECTION







## U.S. CORPORATE HEADQUARTERS

### **LINX TECHNOLOGIES, INC.**

**159 ORT LANE  
MERLIN, OR 97532**

**PHONE: (541) 471-6256**

**FAX: (541) 471-6251**

**[www.linxtechnologies.com](http://www.linxtechnologies.com)**

### **Disclaimer**

---

Linx Technologies is continually striving to improve the quality and function of its products. For this reason, we reserve the right to make changes to our products without notice. The information contained in this Data Guide is believed to be accurate as of the time of publication. Specifications are based on representative lot samples. Values may vary from lot-to-lot and are not guaranteed. "Typical" parameters can and do vary over lots and application. Linx Technologies makes no guarantee, warranty, or representation regarding the suitability of any product for use in any specific application. It is the customer's responsibility to verify the suitability of the part for the intended application. NO LINX PRODUCT IS INTENDED FOR USE IN ANY APPLICATION WHERE THE SAFETY OF LIFE OR PROPERTY IS AT RISK.

Linx Technologies DISCLAIMS ALL WARRANTIES OF MERCHANTABILITY AND FITNESS FOR A PARTICULAR PURPOSE. IN NO EVENT SHALL LINX TECHNOLOGIES BE LIABLE FOR ANY OF CUSTOMER'S INCIDENTAL OR CONSEQUENTIAL DAMAGES ARISING IN ANY WAY FROM ANY DEFECTIVE OR NON-CONFORMING PRODUCTS OR FOR ANY OTHER BREACH OF CONTRACT BY LINX TECHNOLOGIES. The limitations on Linx Technologies' liability are applicable to any and all claims or theories of recovery asserted by Customer, including, without limitation, breach of contract, breach of warranty, strict liability, or negligence. Customer assumes all liability (including, without limitation, liability for injury to person or property, economic loss, or business interruption) for all claims, including claims from third parties, arising from the use of the Products. The Customer will indemnify, defend, protect, and hold harmless Linx Technologies and its officers, employees, subsidiaries, affiliates, distributors, and representatives from and against all claims, damages, actions, suits, proceedings, demands, assessments, adjustments, costs, and expenses incurred by Linx Technologies as a result of or arising from any Products sold by Linx Technologies to Customer. Under no conditions will Linx Technologies be responsible for losses arising from the use or failure of the device in any application, other than the repair, replacement, or refund limited to the original product purchase price. Devices described in this publication may contain proprietary, patented, or copyrighted techniques, components, or materials. Under no circumstances shall any user be conveyed any license or right to the use or ownership of such items.

---