



Chipsmall Limited consists of a professional team with an average of over 10 year of expertise in the distribution of electronic components. Based in Hongkong, we have already established firm and mutual-benefit business relationships with customers from,Europe,America and south Asia,supplying obsolete and hard-to-find components to meet their specific needs.

With the principle of “Quality Parts,Customers Priority,Honest Operation,and Considerate Service”,our business mainly focus on the distribution of electronic components. Line cards we deal with include Microchip,ALPS,ROHM,Xilinx,Pulse,ON,Everlight and Freescale. Main products comprise IC,Modules,Potentiometer,IC Socket,Relay,Connector.Our parts cover such applications as commercial,industrial, and automotives areas.

We are looking forward to setting up business relationship with you and hope to provide you with the best service and solution. Let us make a better world for our industry!



Contact us

Tel: +86-755-8981 8866 Fax: +86-755-8427 6832

Email & Skype: info@chipsmall.com Web: www.chipsmall.com

Address: A1208, Overseas Decoration Building, #122 Zhenhua RD., Futian, Shenzhen, China



Model MDP-ST
Double Banana Plug with Solder Turret Terminals

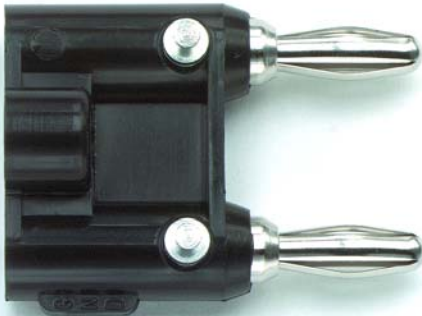

Model MDP-ST
Double Banana Plug with Solder Turret Terminals

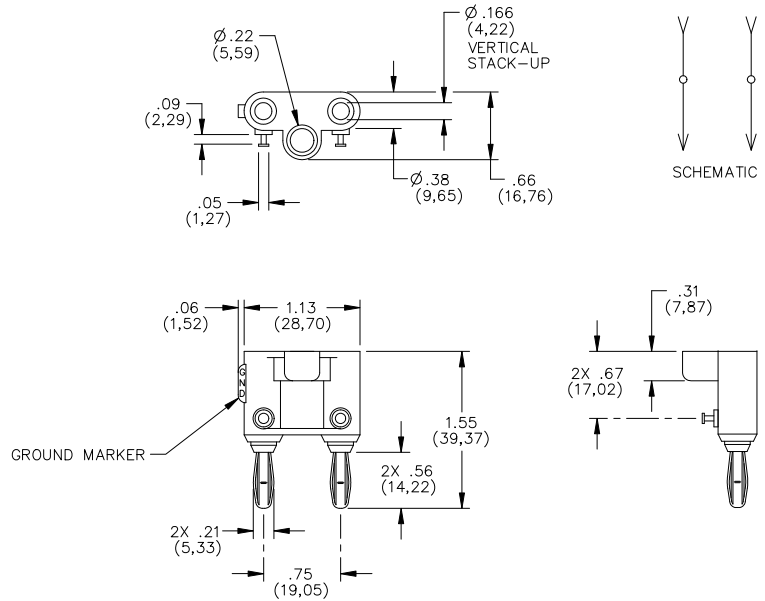

Features

- Simplified attachment of cables or small components by means of solder turrets.
- For test versatility, banana plugs can be vertically stacked to the banana plug.
- Banana plug spring is Beryllium Copper for long insertion life.

Materials

Banana Plug: Body – Brass, Nickel Plated
 Spring – Beryllium Copper, Nickel Plated
 Insulation: Polypropylene, Color: Black
 Marking: “MDP-ST”, “POMONA ELECTRONICS CO, INC. POMONA, CALIF.”

Ratings

Operating Temperature: +55°C. (+122°F.) Max.
 Operating Voltage: Hand-held testing: 30 VAC/60 VDC Max.
 Hands free testing in controlled voltage environments: 5000 WVDC.
 Current: 15 Amps

Ordering Information

Model: MDP-ST
 Color option is black only

USA: Sales: 800-490-2361
 Technical Support: technicalsupport@pomonatest.com
 Fax: 425-446-5844
Europe: 31-(0) 40 2675 150 **International:** 425-446-5500
Where to Buy: www.pomonaelectronics.com

All dimensions are in inches. Tolerances (except noted): .xx = ±.02” (.51 mm), .xxx = ±.005” (.127 mm). All specifications are to the latest revisions. Specifications are subject to change without notice. Registered trademarks are the property of their respective companies.