



Chipsmall Limited consists of a professional team with an average of over 10 year of expertise in the distribution of electronic components. Based in Hongkong, we have already established firm and mutual-benefit business relationships with customers from,Europe,America and south Asia,supplying obsolete and hard-to-find components to meet their specific needs.

With the principle of “Quality Parts,Customers Priority,Honest Operation,and Considerate Service”,our business mainly focus on the distribution of electronic components. Line cards we deal with include Microchip,ALPS,ROHM,Xilinx,Pulse,ON,Everlight and Freescale. Main products comprise IC,Modules,Potentiometer,IC Socket,Relay,Connector.Our parts cover such applications as commercial,industrial, and automotives areas.

We are looking forward to setting up business relationship with you and hope to provide you with the best service and solution. Let us make a better world for our industry!



## Contact us

Tel: +86-755-8981 8866 Fax: +86-755-8427 6832

Email & Skype: info@chipsmall.com Web: www.chipsmall.com

Address: A1208, Overseas Decoration Building, #122 Zhenhua RD., Futian, Shenzhen, China



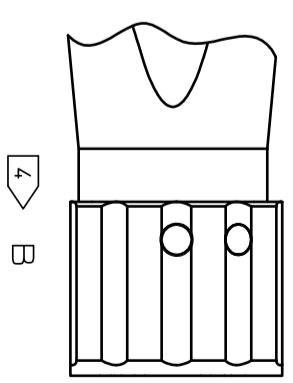
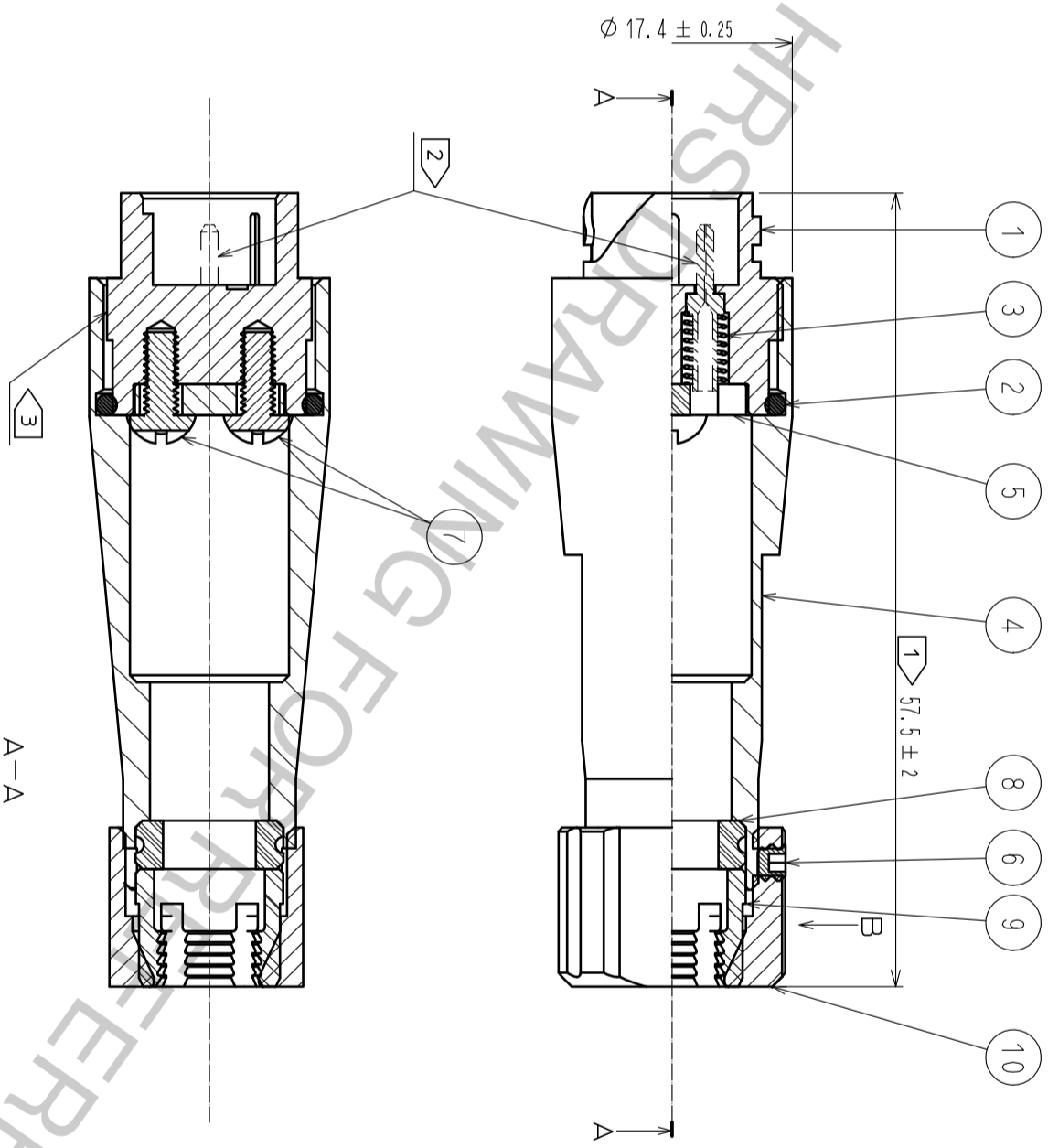
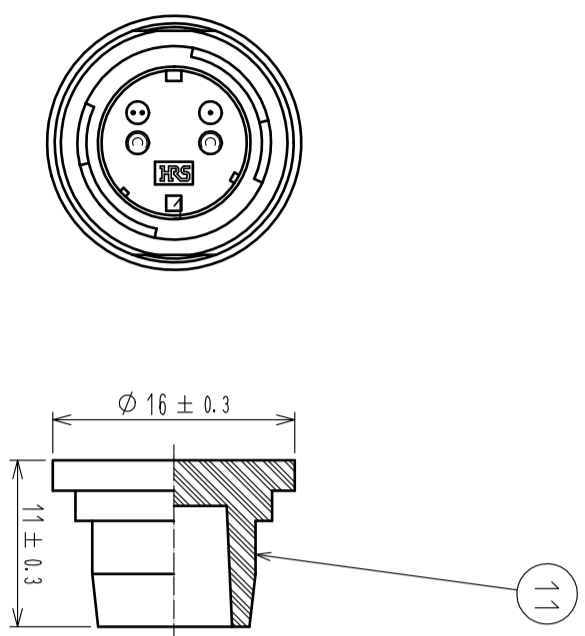

NOTE

- 1 These are indicates the dimensions of after assembling
- 2 Ferrules are not included in this product. MU Ferrules are sold separately.
- 3 Apply adhesive to around the threads of R-shell-(part No.1) before tighten Hood(part No.4).
- 4 Clamp ring has two holes for fixing hexagon socket screw.  
Tighten the screw at visible either hole with tightening torque 25N·cm. or either hole if both holes are visible.

NO.	MATERIAL	FINISH	REMARKS	NO.	MATERIAL	FINISH	REMARKS
6	STAINLESS STEEL			11	SILICONE RUBBER	COLOR:BLACK	
5	PBT RESIN	COLOR:BLACK		10	ZINC ALLOY DIE CASTING	CHROME PLATING(COLOR:BLACK)	
4	ALUMINUM ALLOY	ANODIC OXIDE COATING		9	PA RESIN	COLOR:WHITE	
3	PLANO WIRE	ZINC PLATING * BAKING		8	CHLOROPRENE RUBBER	COLOR:BLACK	
2	NITRILE BUTADIENE RUBBER	COLOR:BLACK		7	STAINLESS STEEL		
1	ZINC ALLOY DIE CASTING	CHROME PLATING(COLOR:BLACK)					

UNITS	SCALE	COUNT	DESCRIPTION OF REVISIONS	DESIGNED	CHECKED	DATE
mm	2 : 1					

<b>HRS</b> HIROSE ELECTRIC CO., LTD.	APPROVED : MT. SHIBUTANI	18.03.29	DRAWING NO.	EDC-177477-32-00
	CHECKED : MT. SHIBUTANI	18.03.29	PART NO.	MF10B-WJ6.5CH01-0200(32)
	DESIGNED : SI. MATSUMOTO	18.03.29	CODE	CL709-1035-5-32
	DRAWN : SI. MATSUMOTO	18.03.29	NO.	1