



Chipsmall Limited consists of a professional team with an average of over 10 year of expertise in the distribution of electronic components. Based in Hongkong, we have already established firm and mutual-benefit business relationships with customers from,Europe,America and south Asia,supplying obsolete and hard-to-find components to meet their specific needs.

With the principle of “Quality Parts,Customers Priority,Honest Operation,and Considerate Service”,our business mainly focus on the distribution of electronic components. Line cards we deal with include Microchip,ALPS,ROHM,Xilinx,Pulse,ON,Everlight and Freescale. Main products comprise IC,Modules,Potentiometer,IC Socket,Relay,Connector.Our parts cover such applications as commercial,industrial, and automotives areas.

We are looking forward to setting up business relationship with you and hope to provide you with the best service and solution. Let us make a better world for our industry!



Contact us

Tel: +86-755-8981 8866 Fax: +86-755-8427 6832

Email & Skype: info@chipsmall.com Web: www.chipsmall.com

Address: A1208, Overseas Decoration Building, #122 Zhenhua RD., Futian, Shenzhen, China



MFA350 Series

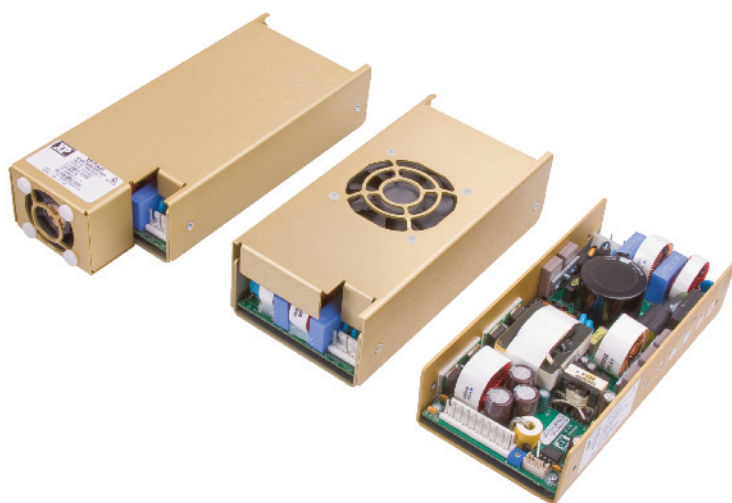

- Screw Terminals Available
- U Channel & Cover Fan Formats
- High Power Density 11.1 W/in³
- 5 V Standby & 12 V Fan Outputs
- Active Current Share
- Remote On/Off
- AC & DC OK Signals
- -10 °C to +70 °C Operation
- Level B Conducted Emissions

The MFA350 has been designed with multiple mechanical options to facilitate its integration into a wide range of applications. Designers of these systems demand higher power from AC-DC units in industry-standard formats as processing power and functionality grows within tight space constraints. The MFA350 delivers over 350 W across the full universal AC input range from an industry-standard 3.2 x 6.8 inch (81.3 x 172.7 mm) footprint. It is 1.5 inches (38.1 mm) high and achieves 11.1 Watts per cubic inch power density without compromising performance or functionality.

With efficiency up to 88% at full load, the MFA350 operates up to 50 °C ambient and up to 70 °C ambient with derating. The main output is 12, 24 or 48 VDC but each power supply also has a 5 V, 0.3 A standby output and a 12 V, 1A output for powering fans. The unit incorporates a fully featured signal set including AC OK/DC OK, remote on/off and active current sharing.

Models and Ratings

Output Voltage V1	Maximum Output Current	Fan Output ⁽²⁾ V2	Standby Supply V3	Max Power 13 CFM Airflow	Model Number ⁽¹⁾
12.0 VDC	29.0 A	12 V/1 A	5 V/0.3 A	361 W	MFA350PS12
24.0 VDC	14.5 A	12 V/1 A	5 V/0.3 A	361 W	MFA350PS24
48.0 VDC	7.3 A	12 V/1 A	5 V/0.3 A	364 W	MFA350PS48

Notes

- Units supplied with AMP/TE connections for J1 & J2 as standard. Add suffix '-S' to model number to replace with screw terminals. Add suffix '-TF' for covered version with top fan and suffix '-EF' for covered version with end fan. Example:- MFA350PS12-STF, 12V unit fitted with screw terminals and top fan.
- Not available for -TF & -EF versions.

Input Characteristics

Characteristic	Minimum	Typical	Maximum	Units	Notes & Conditions
Input Voltage - Operating	85		264	VAC	Derate output power 10% < 90 VAC
Input Frequency	47	50/60	63	Hz	
Power Factor		>0.9			EN61000-3-2 class A EN61000-3-2 class C for loads ≥20%
Input Current - No Load		100		mA	
Input Current - Full Load		3.6/1.8		A	115/230 VAC
Inrush Current			60	A	230 VAC cold start
Earth Leakage Current		1		mA	230 VAC/50 Hz
Input Protection	T6.3A/250V internal fuse in line				

Output Characteristics

Characteristic	Minimum	Typical	Maximum	Units	Notes & Conditions
Output Voltage - V1	12		48	VDC	See Models and Ratings table
Initial Set Accuracy			±1 ^(V1) , ±5 ^(V2) & ±3 ^(V3)	%	
Output Voltage Adjustment	±10			%	
Minimum Load	0				No minimum load required
Start Up Delay		1	2	s	90 VAC full load (see fig. 1)
Hold Up Time	16	20		ms	90 VAC full load (see fig. 2 & 3)
Drift			±0.2	%	After 20 min warm up
Line Regulation			±0.5 ^(V1) , ±3 ^(V2) & ±3 ^(V3)	%	
Load Regulation			±1 ^(V1) , ±5 ^(V2) & ±3 ^(V3)	%	0-100% load. V2 10-100% load
Transient Response - V1			4	%	Recovery within 1% in less than 500 μs for a 50-75% and 75-50% load step
Over/Undershoot - V1			1	%	(see fig. 4)
Ripple & Noise			1 ^(V1 & V3) & 2 ^(V2)	% pk-pk	20 MHz bandwidth (see fig. 6 & 7)
Overvoltage Protection	115		140	%	Vnom DC. Output 1 only, recycle input to reset
Overload Protection	110		140	% I nom	Output 1 only, auto reset (see fig. 5)
Short Circuit Protection					Continuous
Temperature Coefficient			0.05	%/°C	
Overtemperature Protection		75		°C	Thermal sensor under PCB

Start Up Delay From AC Turn On

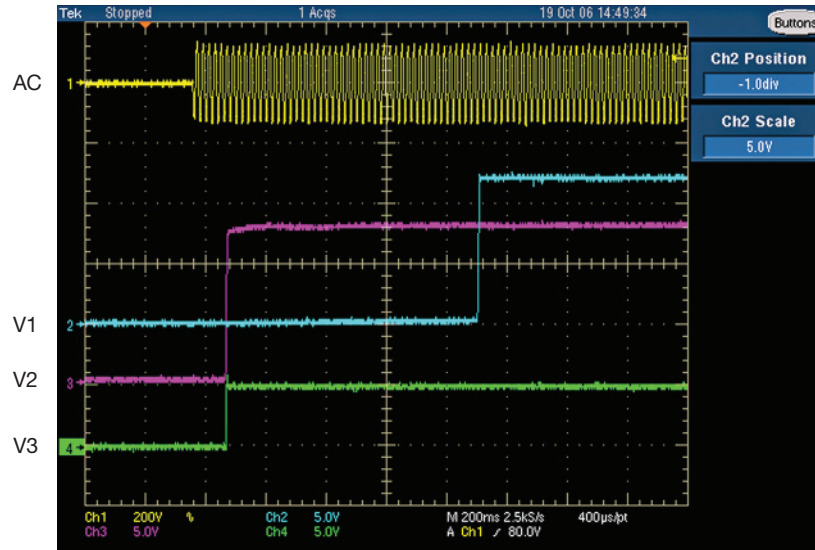

Figure 1
Example of start up all outputs

Hold Up Time From Loss of AC

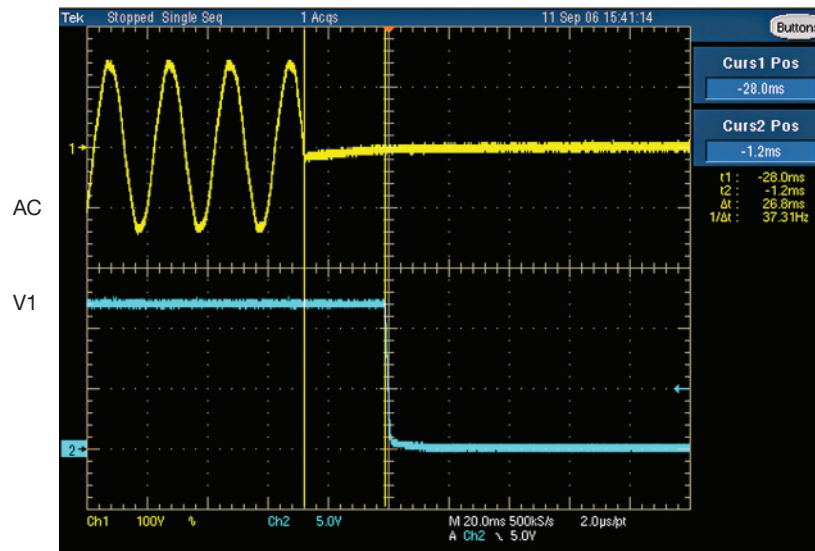

Figure 2
V1 hold up at full load with 90 VAC input (26.8 ms)

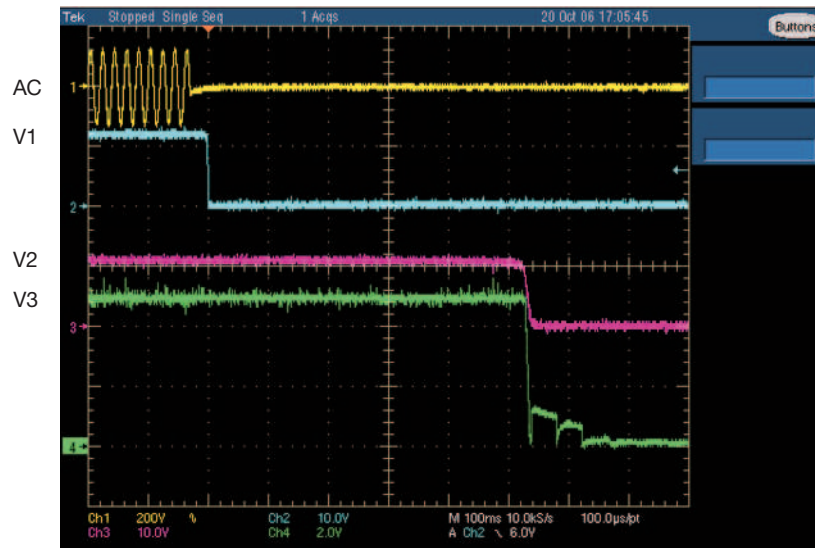

Figure 3
Full load 90 VAC input

Output Overshoot

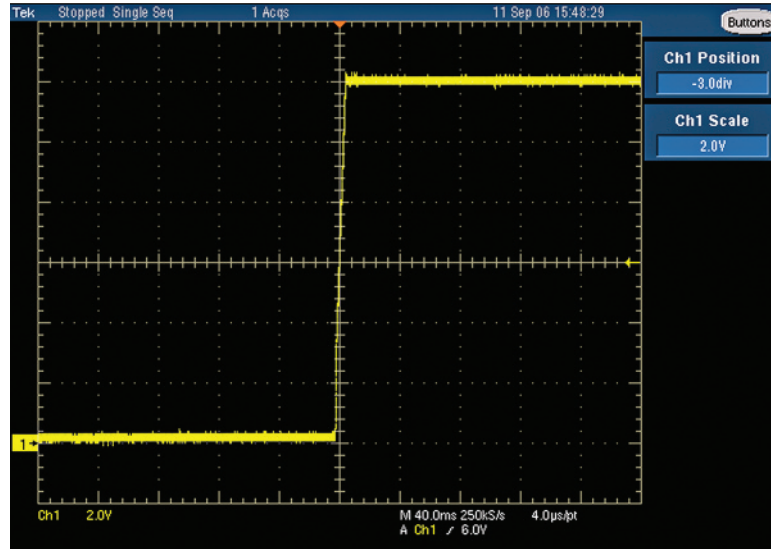

Figure 4
Typical Output Overshoot
(MFA350PS12)

Output Overload Characteristic

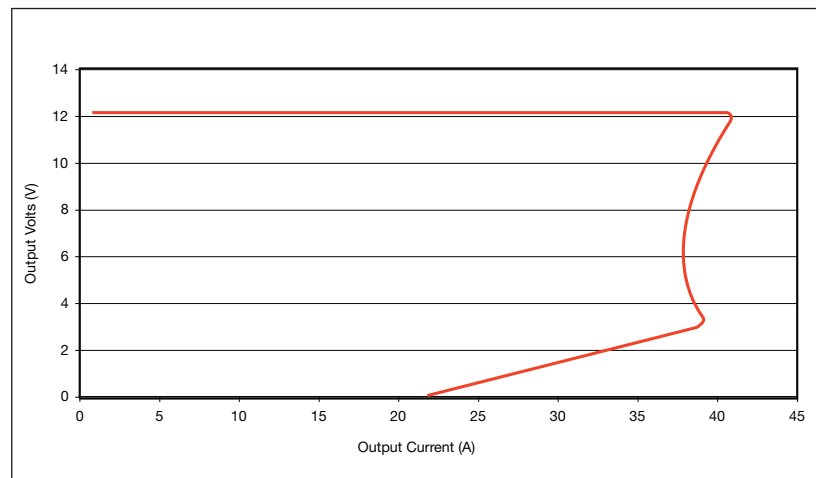

Figure 5

Output Ripple & Noise

Figure 6
V1 MFA350PS12 (full load)
80 mV pk-pk ripple. 20 MHz BW

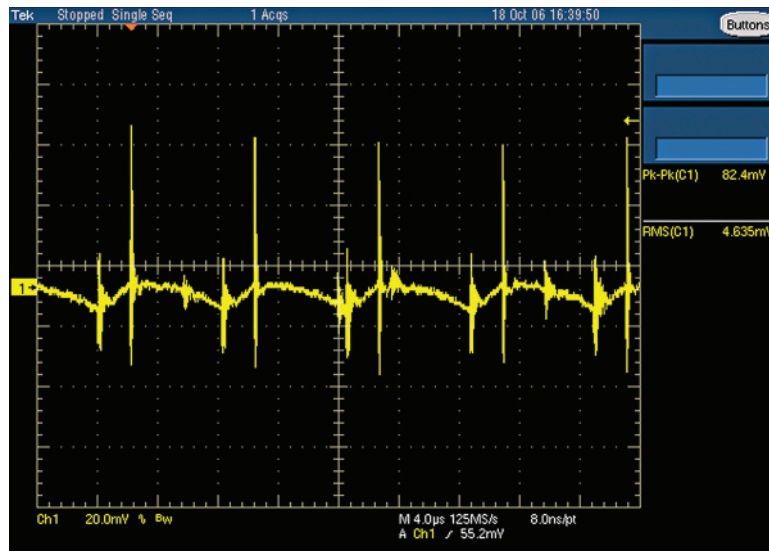
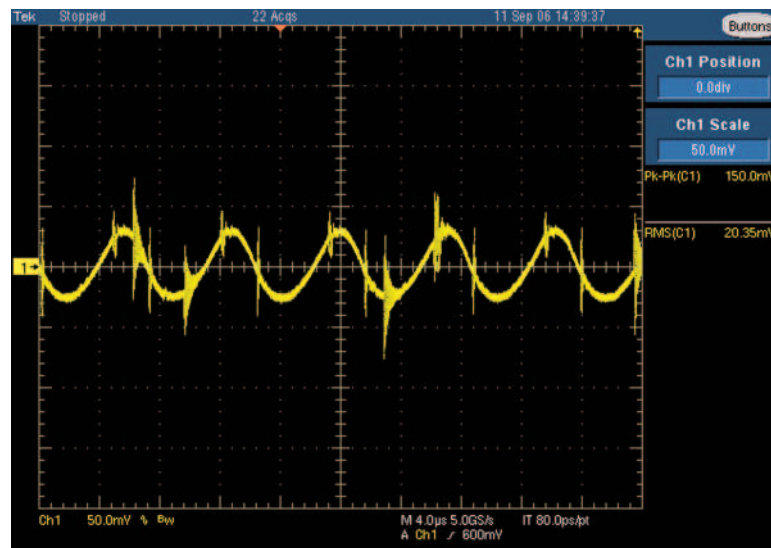

Figure 7
V1 MFA350PS48 (full load)
150 mV pk-pk ripple. 20 MHz BW



General Specifications

Characteristic	Minimum	Typical	Maximum	Units	Notes & Conditions
Efficiency		86		%	Full load (see fig. 8 & 9)
Isolation: Input to Output Input to Ground Output to Ground	3000			VAC	
	1500			VAC	
	100			VDC	
Switching Frequency: PFC Main Converter		62		kHz	
		157		kHz	
Power Density			11.1	W/in ³	
Mean Time Between Failure		460		kHrs	MIL-HDBK-217F, Notice 2 +25 °C GB
Weight			1.35 (612)	lb (g)	

Characteristic	Notes & Conditions
Signals	
AC OK/Powerfail	Open collector referenced to output 0V, transistor normally off when AC is good (see fig. 10, 16, 17 & 18) AC OK: Provides ≥ 5 ms warning of loss of output from AC failure
DC OK	Open collector referenced to 0V, transistor normally off when DC is good (see fig. 11, 19 & 20). Provides warning of DC output failure
Remote On/Off (Inhibit/Enable)	Remotely switches outputs off, can also be configured as enable (see fig.12)
Current Share	Up to 3 supplies can be connected in parallel. Output current is shared within 10% at full load. Derate overall output current to 90% when used in parallel (see fig.13, 14 & 15)
Remote Sense	Compensates for 0.5 V total voltage drop

Efficiency Versus Load

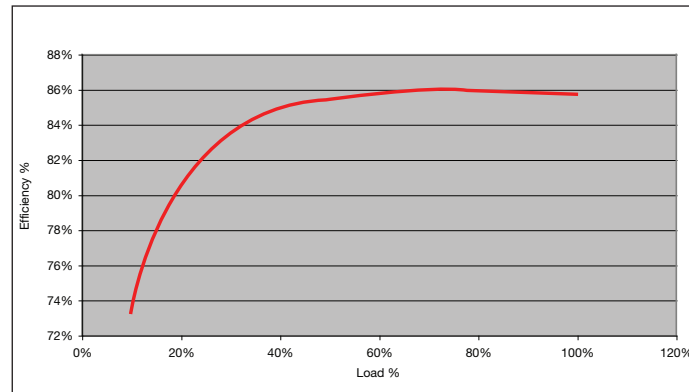

Figure 8
MFA350PS12 @ 230 VAC

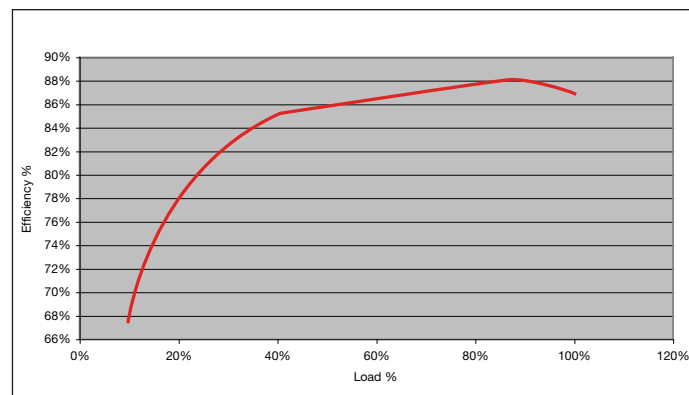
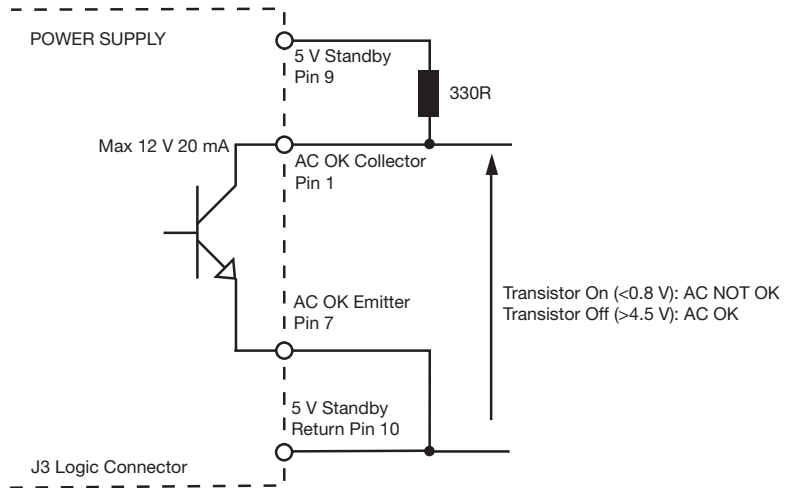

Figure 9
MFA350PS48 @ 230 VAC

Signals

AC OK/Power Fail

Figure 10



DC OK

Figure 11

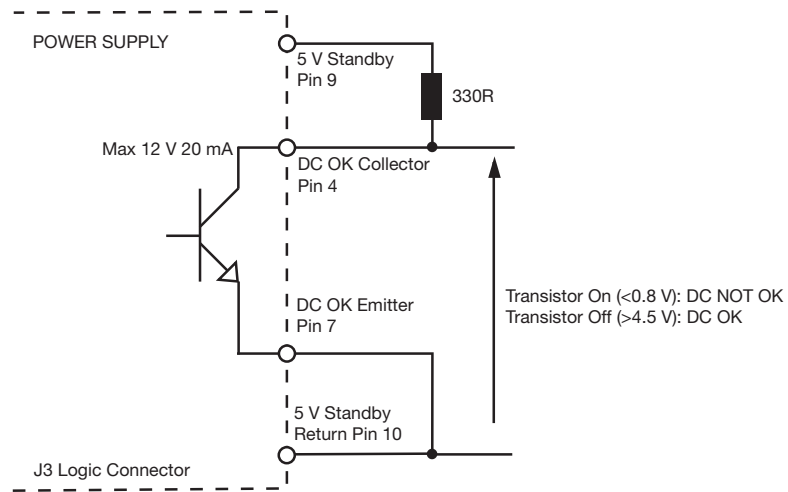

Remote On/Off (Inhibit)

Figure 12

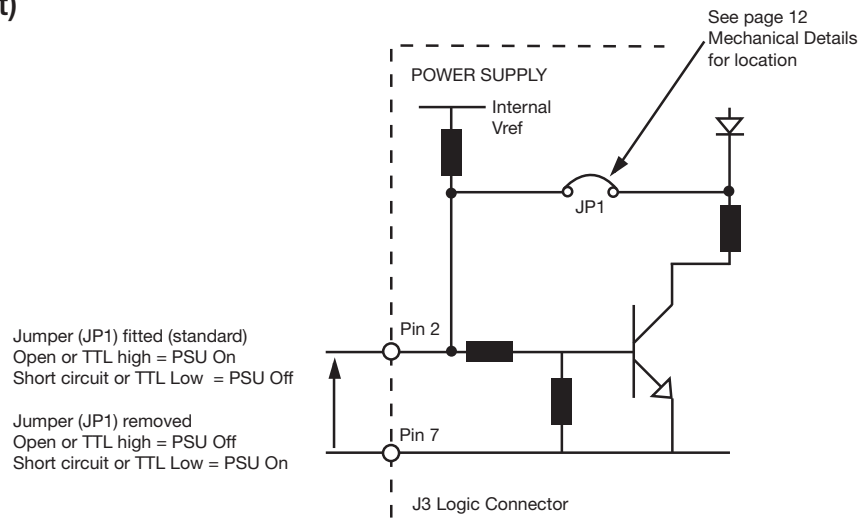

Signals

Parallel Load & Current Share Connections

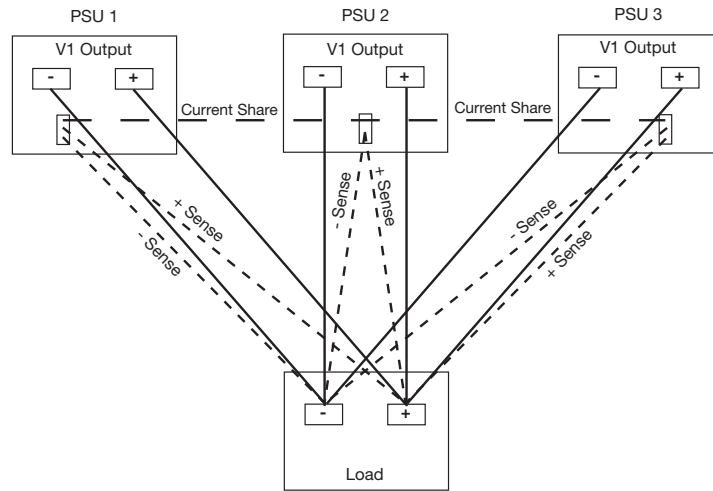

Figure 13

Parallel AC OK Connection (DC OK follows same format)

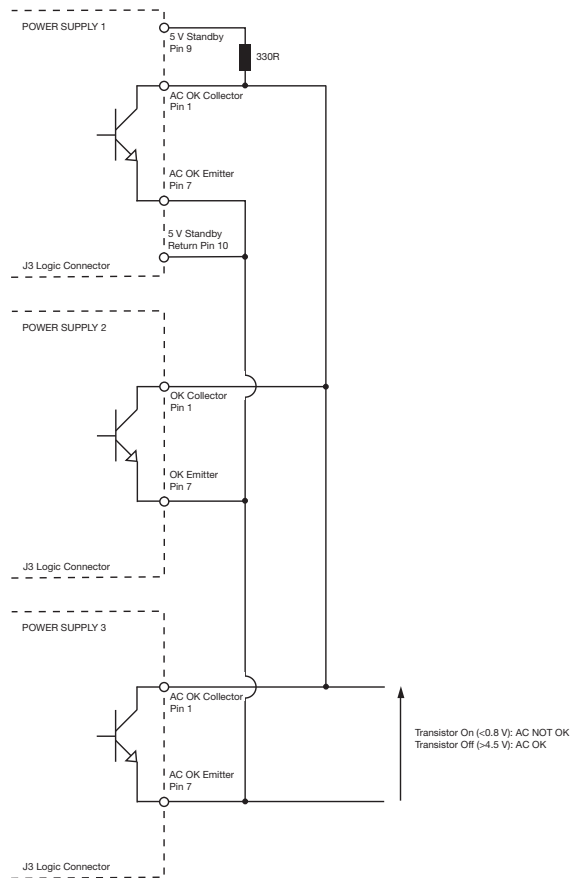

Figure 14

Parallel Remote On/Off (Inhibit) Connection

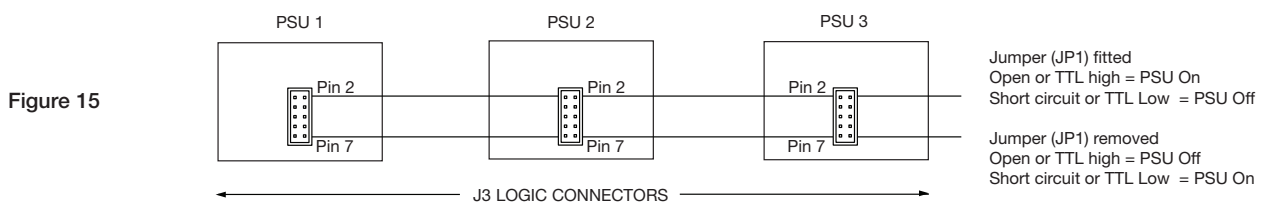

Figure 15

Signals

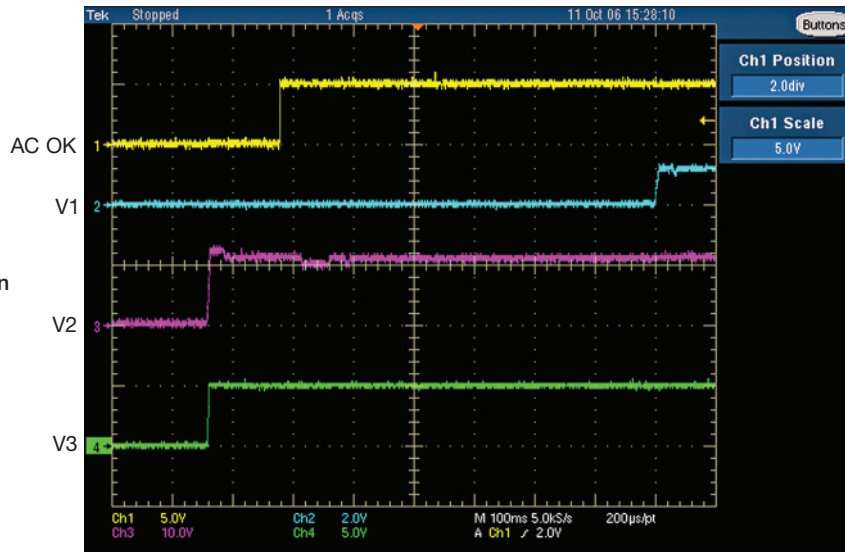

Figure 16
AC OK signal at AC switch on

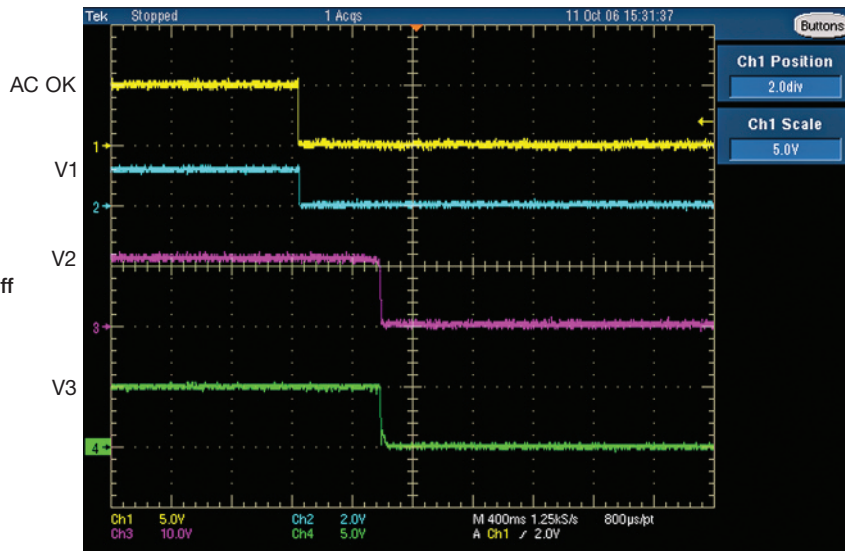

Figure 17
AC OK signal at AC switch off

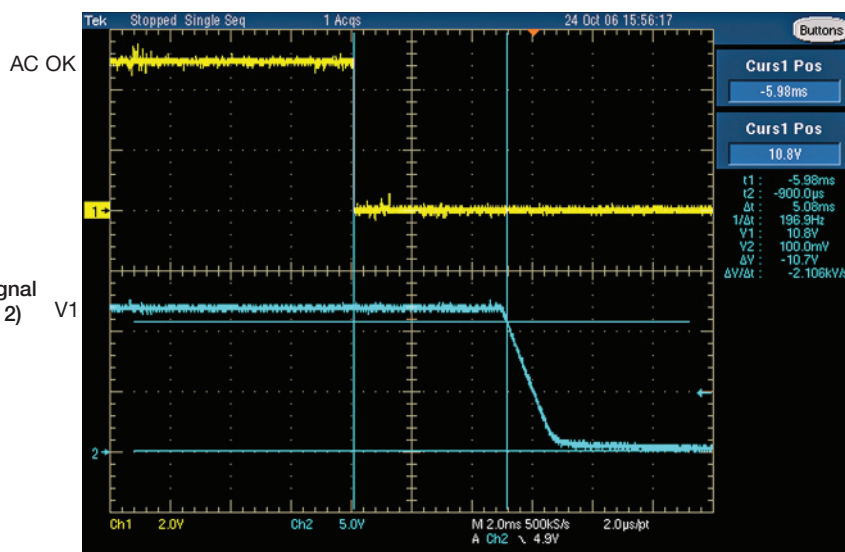

Figure 18
V1 warning time at AC OK signal
90 VAC full load (MFA350PS12)

Signals

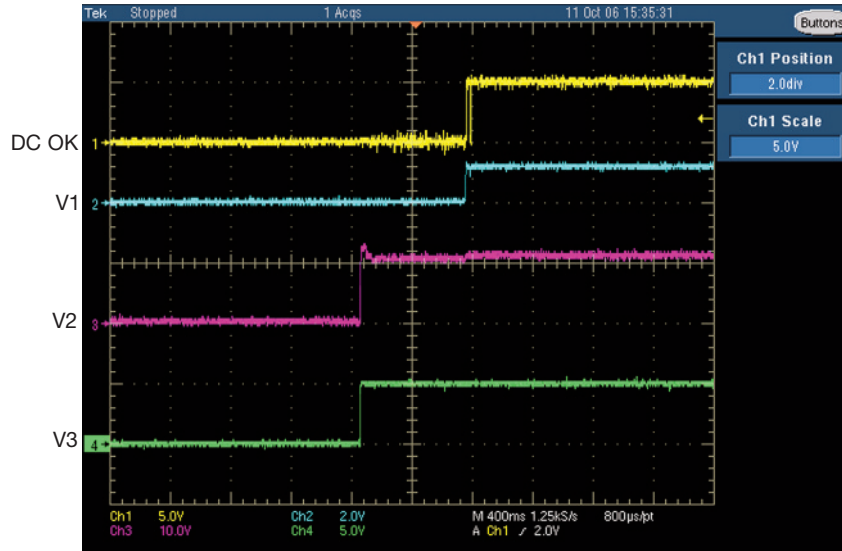

Figure 19
DC OK at AC switch on

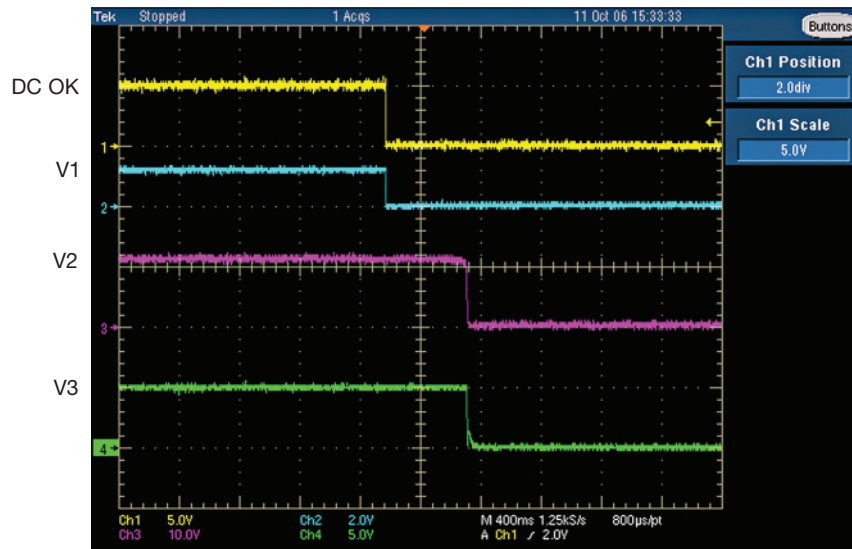

Figure 20
DC OK at AC switch off

Environmental

Characteristic	Minimum	Typical	Maximum	Units	Notes & Conditions
Operating Temperature	-10		+70	°C	Derate linearly from +50 °C at 2.5%/°C to 50% at 70 °C when forced cooled. See Thermal Considerations.
Storage Temperature	-20		+85	°C	
Cooling	13			CFM	U Channel Version. -TF & -EF models have integral fan. See Thermal Considerations for U Channel.
Humidity	5		95	%RH	Non-condensing
Operating Altitude			3000	m	
Shock					3 x 30 g/11 ms shocks in both +ve & -ve directions along the 3 orthogonal axis, total 18 shocks.
Vibration					Single axis 10-500 Hz at 2 g x 10 sweeps

Electromagnetic Compatibility - Immunity

Phenomenon	Standard	Test Level	Criteria	Notes & Conditions
Harmonic Current	EN61000-3-2	Class A		
		Class C		For loads ≥20%
EFT	EN61000-4-4	3	A	
Surges	EN61000-4-5	Installation Class 3	A	
Conducted	EN61000-4-6	10 V rms	A	
Dips and Interruptions	EN61000-4-11	30% 10 ms	A	
		60% 100 ms	B	
		100% 5000 ms	B	

Electromagnetic Compatibility - Emissions

Phenomenon	Standard	Test Level	Criteria	Notes & Conditions
Conducted	EN55022	Class B		See fig. 21
Radiated	EN55022	Class A		
Voltage Fluctuations	EN61000-3-3			

Typical EMC Plot

Figure 21

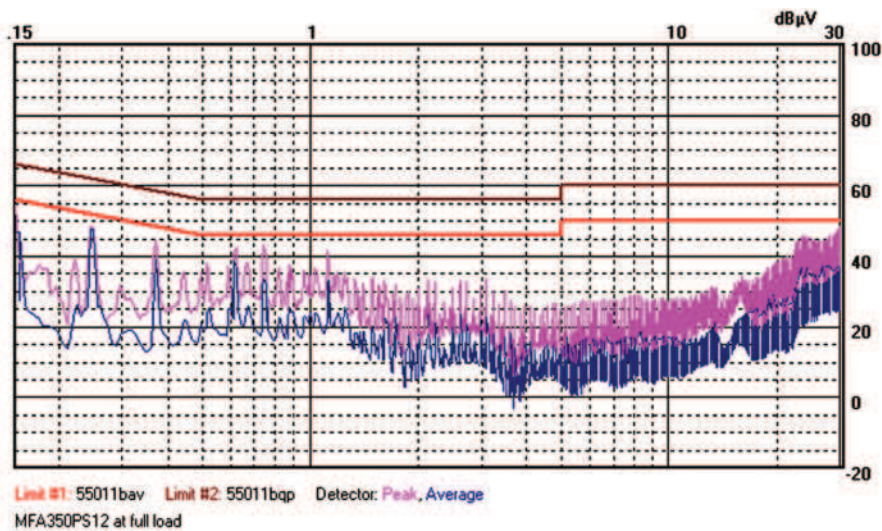

Safety Agency Approvals

Safety Agency	Safety Standard	Category
CB Report	CSA #1790948 IEC60950-1:2001	Information Technology
CSA	CSA certificate #179094 CSA22.2 No. 60950-1-05	Information Technology
UL	UL File #E139109 UL60950-1 (2003)	Information Technology
TUV	TUV Certificate #B 07 02 57396 024 EN60950-1/A11:2004	Information Technology
CE	LVD	

Mechanical Details

U Channel Version

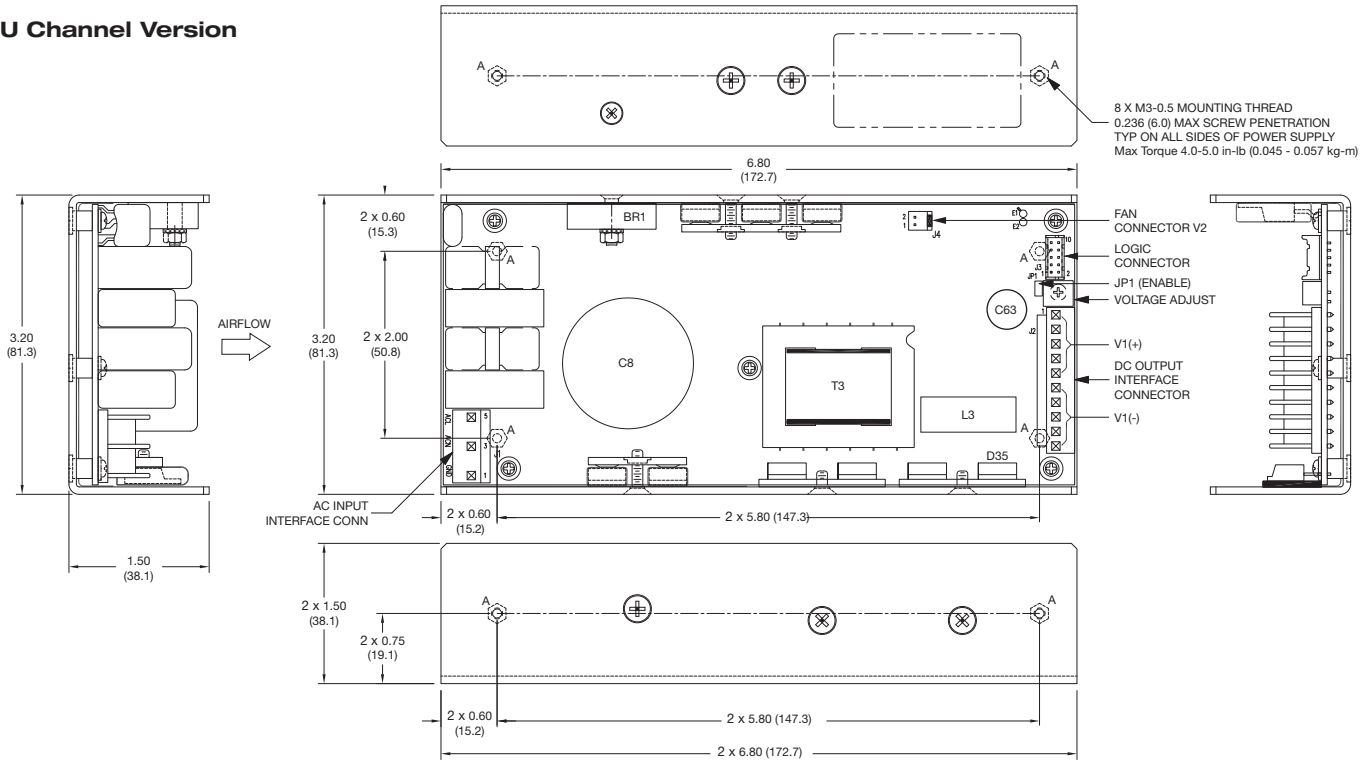

Top Fan Version (Suffix TF)

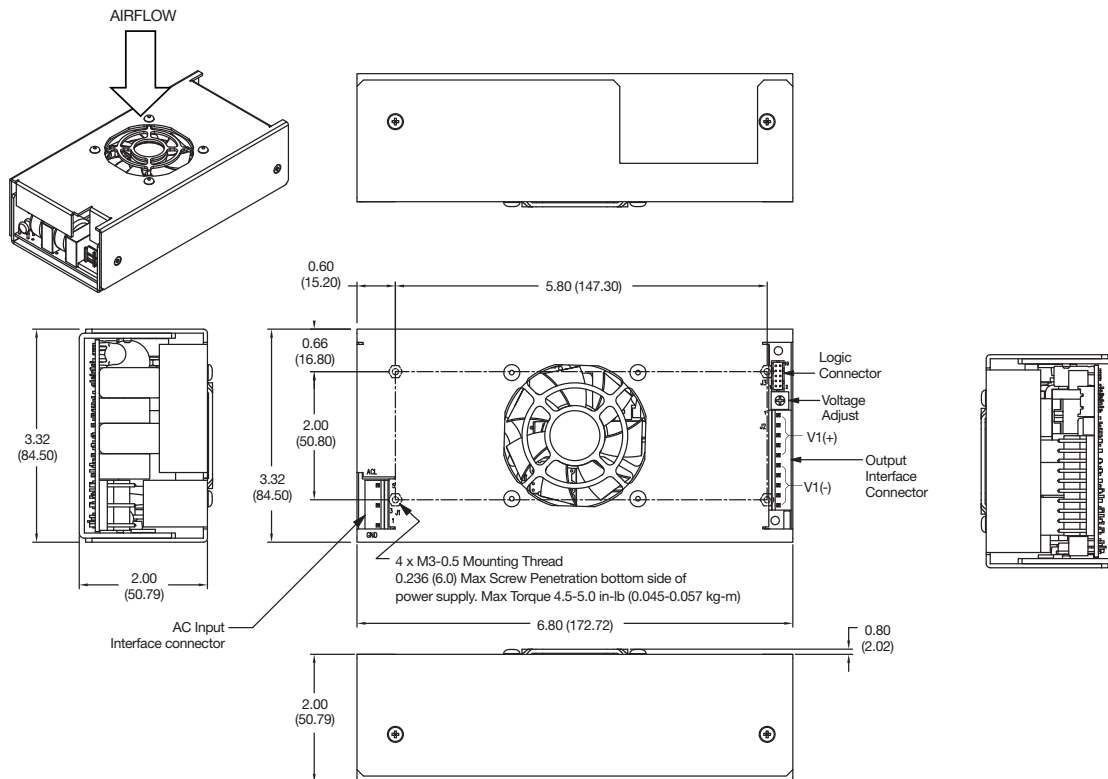

Notes

1. All dimensions in inches (mm).
2. Tolerance: X.XX = ±0.02 (±0.50), X.XXX = ±0.01 (±0.25)

Mechanical Details

End Fan Version (Suffix EF)

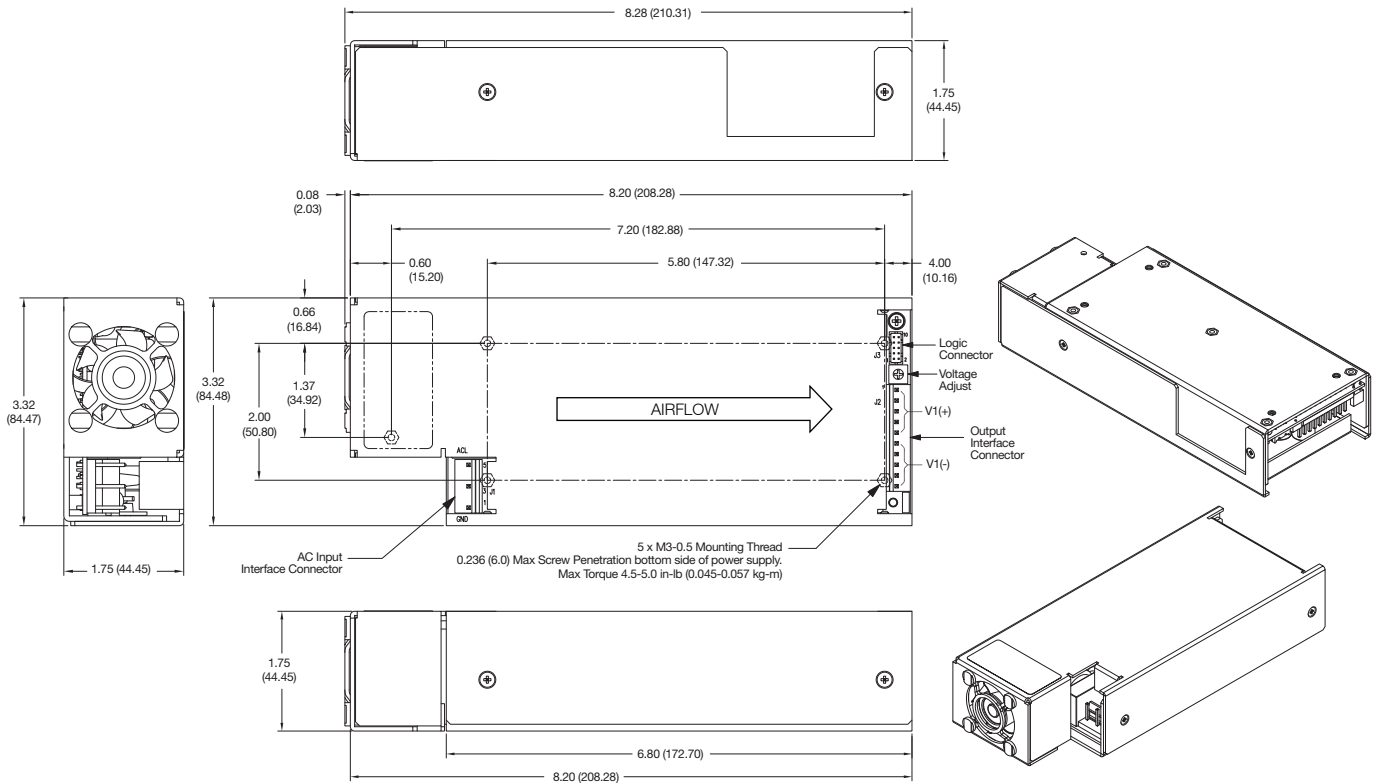

Notes

1. All dimensions in inches (mm).
2. Tolerance: X.XX = ± 0.02 (± 0.50), X.XXX = ± 0.01 (± 0.25)

Mechanical Details - Pin Connections

PIN CONNECTIONS AC INPUT J1 AMP/TE CONN = 640445-5	
1	GND
3	Neutral
5	Line

Mating Parts:
AMP/TE CONN Housing =
640250-5
Contact 350980-1

Option '-S' screw terminals
Phoenix Contact:
MKDS 1/5-3.81 or similar
accepts 26-16 AWG wire
(contacts 2 & 4 removed)

Max Torque 1.73 in-lb
(0.02 kg-m)

PIN CONNECTIONS DC OUTPUT J2 AMP/TE CONN = 1-640445-0	
1	+V1
2	+V1
3	+V1
4	+V1
5	+V1
6	-V1
7	-V1
8	-V1
9	-V1
10	-V1

Mating Parts:
AMP/TE CONN = 1-640250-0
Contact 350980-1

Option '-S' screw terminals
2 x Phoenix Contact:
MKDS 1/5-3.81 or similar
accepts 26-16 AWG wire

Max Torque 1.73 in-lb (0.02 kg-m)

PIN CONNECTIONS LOGIC CONNECTOR J3 JST B10B-PHDSS (LF) (SN)	
1	AC OK
2	ROF (Inhibit/Enable)
3	Current Share
4	DC OK
5	Not used
6	+Sense
7	-Sense
8	Not Used
9	5 V Standby V3
10	5 V Standby Return V3

Mating Parts:
JST Housing PHDR-10VS
Contact SPHD-001T-P0.5

PIN CONNECTIONS FAN OUTPUT J4 Molex 22-04-1021	
1	-V2
2	+V2

Mating Parts:
Molex Housing 22-01-1024
Contact 08-70-0057

Thermal Considerations (U Channel)

In order to ensure correct and reliable operation of the PSU in the most adverse conditions permitted in the end-use equipment, the temperature of the components listed in the table below must not be exceeded. See drawing on page 12 for component locations. Temperature should be monitored using K type thermocouples placed on the hottest part of the component (out of any direct air flow).

Temperature Measurements (Ambient ≤ 50 °C)	
Component	Max Temperature °C
T3	90 °C
BR1	105 °C
D35	85 °C
L3	90 °C

Service Life

The estimated service life of the MFA350 is determined by the cooling arrangements and load conditions experienced in the end application. Due to the uncertain nature of the end application this estimated service life is based on the actual measured temperature of two key capacitors within the product when installed in the end application. The highest of the two component temperatures should be used. The graph below expresses the estimated lifetime for a given component temperature and assumes continuous operation at this temperature.

Estimated Service Life vs Component Temperature

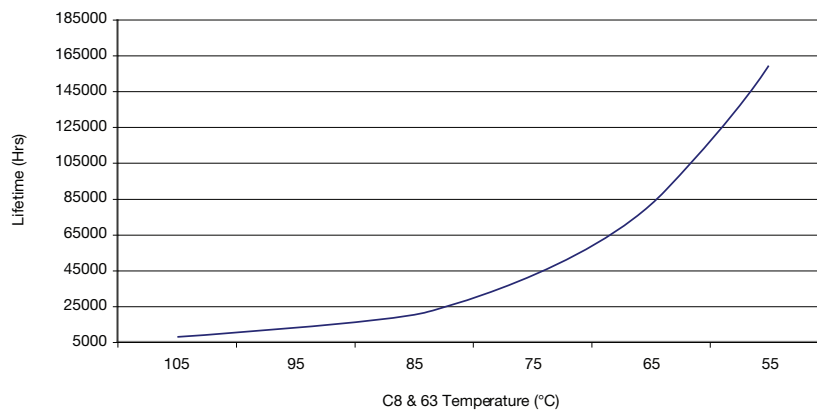

MFA420 Series

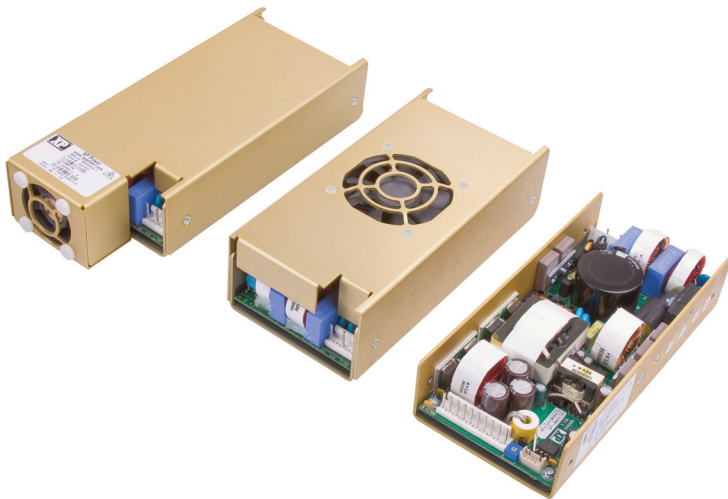

- Screw Terminals Available
- U Channel & Cover Fan Formats
- High Power Density 13.3 W/in³
- 5 V Standby & 12 V Fan Outputs
- Active Current Share
- Remote On/Off
- AC & DC OK Signals
- -10 °C to +70 °C Operation
- Level B Conducted Emissions

The MFA420 has been designed with multiple mechanical options to facilitate its integration into a wide range of applications. Designers of these systems demand higher power from AC-DC units in industry-standard formats as processing power and functionality grows within tight space constraints. The MFA420 delivers over 420 W across the full universal AC input range from an industry-standard 3.2 x 6.8 inch (81.3 x 172.7 mm) footprint. It is 1.5 inches (38.1 mm) high and achieves 13.3 Watts per cubic inch power density without compromising performance or functionality.

With efficiency up to 88% at full load, the MFA420 operates up to 50 °C ambient and up to 70 °C ambient with derating. The main output is 12, 24 or 48 VDC but each power supply also has a 5 V, 0.3 A standby output and a 12 V, 1A output for powering fans. The unit incorporates a fully featured signal set including AC OK/DC OK, remote on/off and active current sharing.

Models and Ratings

Output Voltage V1	Maximum Output Current	Fan Output V2 ⁽²⁾	Standby Supply V3	Max Power 13 CFM Airflow	Model Number ⁽¹⁾
12.0 VDC	35.0 A	12 V/1 A	5 V/0.3 A	434 W	MFA420PS12
24.0 VDC	17.5 A	12 V/1 A	5 V/0.3 A	434 W	MFA420PS24
48.0 VDC	8.8 A	12 V/1 A	5 V/0.3 A	436 W	MFA420PS48

Notes

- Units supplied with Molex connections for J1 & J2 as standard. Add suffix '-S' to model number to replace with screw terminals. Add suffix '-TF' for covered version with top fan and suffix '-EF' for covered version with end fan. Example:- MFA420PS12-STF, 12V unit fitted with screw terminals and top fan.
- Not available for -TF & -EF versions.

Input Characteristics

Characteristic	Minimum	Typical	Maximum	Units	Notes & Conditions
Input Voltage - Operating	85		264	VAC	Derate output power 10% < 90 VAC
Input Frequency	47	50/60	63	Hz	
Power Factor		>0.9			EN61000-3-2 class A EN61000-3-2 class D
Input Current - No Load		100		mA	
Input Current - Full Load		3.6/1.8		A	115/230 VAC
Inrush Current			60	A	230 VAC cold start
Earth Leakage Current		1		mA	230 VAC/50 Hz
Input Protection	T6.3A/250 V internal fuse in line				

Output Characteristics

Characteristic	Minimum	Typical	Maximum	Units	Notes & Conditions
Output Voltage - V1	12		48	VDC	See Models and Ratings table
Initial Set Accuracy			$\pm 1^{(V1)}$, $\pm 5^{(V2)}$ & $\pm 3^{(V3)}$	%	
Output Voltage Adjustment	± 10			%	
Minimum Load	0				No minimum load required
Start Up Delay		1	2	s	90 VAC full load (see fig. 1)
Hold Up Time	16	20		ms	90 VAC full load (see fig. 2 & 3)
Drift			± 0.2	%	After 20 min warm up
Line Regulation			$\pm 0.5^{(V1)}$, $\pm 3^{(V2)}$ & $\pm 3^{(V3)}$	%	
Load Regulation			$\pm 1^{(V1)}$, $\pm 5^{(V2)}$ & $\pm 3^{(V3)}$	%	0-100% load. V2 10-100% load
Transient Response - V1			4	%	Recovery within 1% in less than 500 μ s for a 50-75% and 75-50% load step
Over/Undershoot - V1			1	%	(see fig. 4)
Ripple & Noise			$1^{(V1 \& V3)}$ & $2^{(V2)}$	% pk-pk	20 MHz bandwidth (see fig. 6 & 7)
Overvoltage Protection	115		140	%	Vnom DC. Output 1 only, recycle input to reset
Overload Protection	110		140	% I nom	Output 1 only, auto reset (see fig. 5)
Short Circuit Protection					Continuous
Temperature Coefficient			0.05	%/°C	
Overtemperature Protection		75		°C	Thermal sensor under PCB

Start Up Delay From AC Turn On

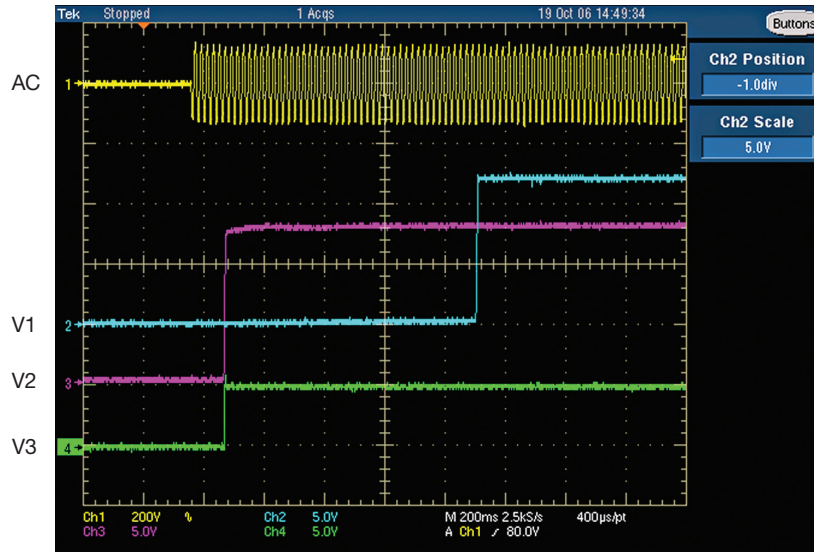

Figure 1
Example of start up all outputs
(taken from MFA350PS12)

Hold Up Time From Loss of AC

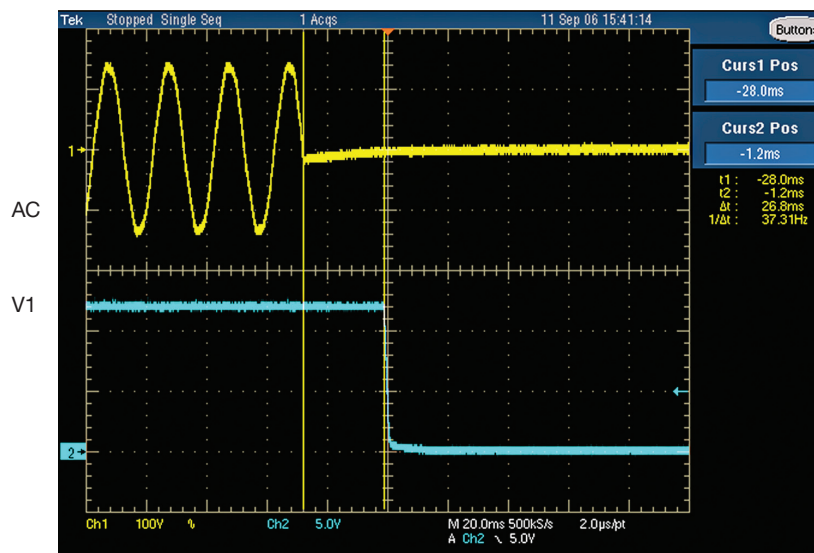

Figure 2
V1 hold up at full load with
90 VAC input (26.8 ms)
(taken from MFA350PS12)

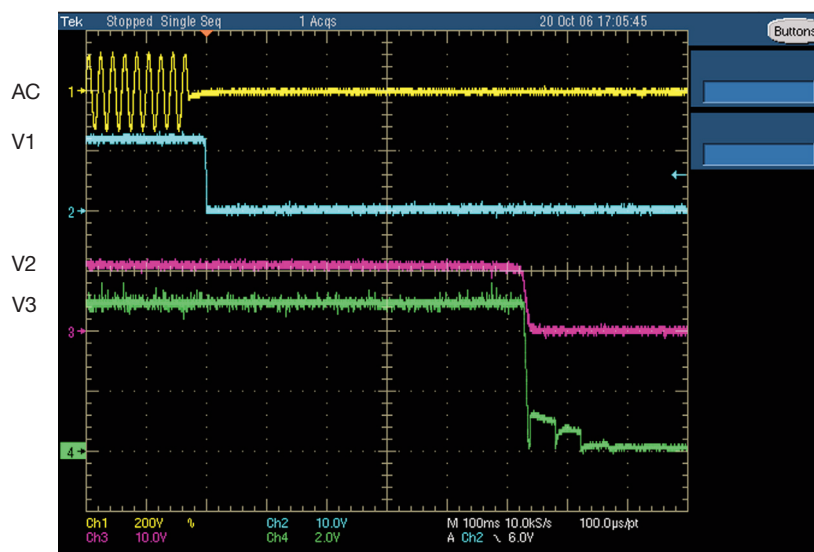

Figure 3
Full load 90 VAC input
(taken from MFA350PS12)

Output Overshoot

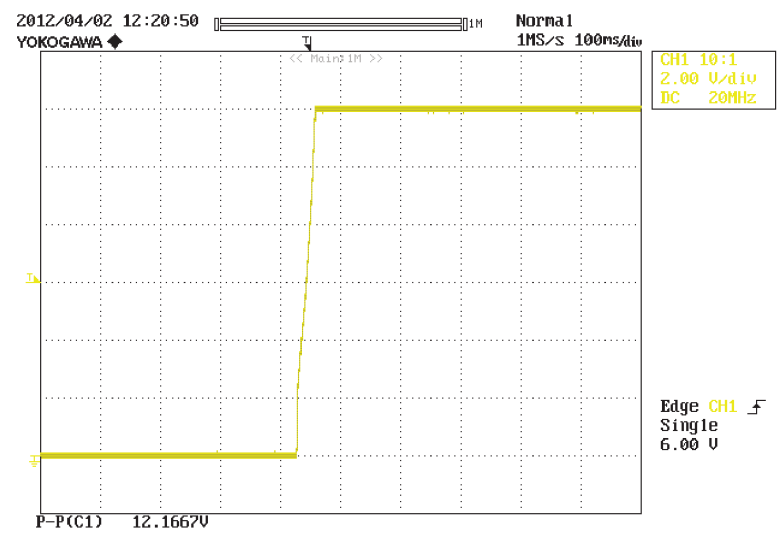

Figure 4
Typical Output Overshoot
(MFA420PS12)

Output Overload Characteristic

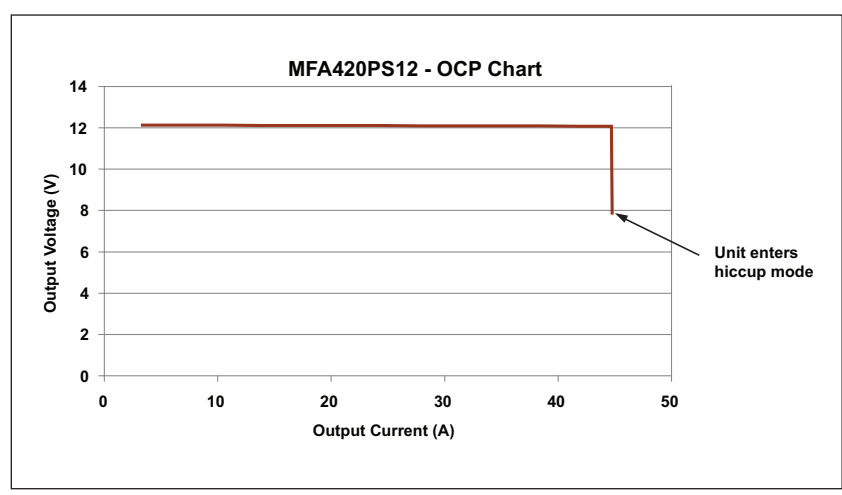

Figure 5
Typical output overload
(MFA420PS12)

Output Ripple & Noise

Figure 6
V1 MFA420PS12 (full load)
45 mV pk-pk ripple. 20 MHz BW

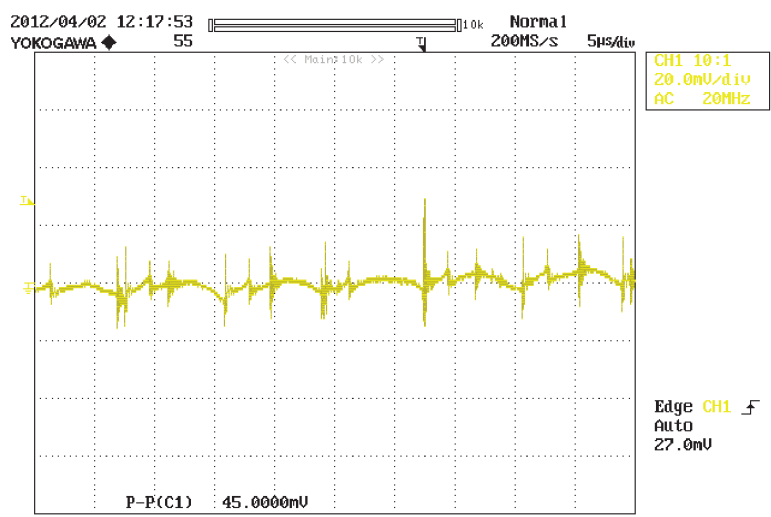
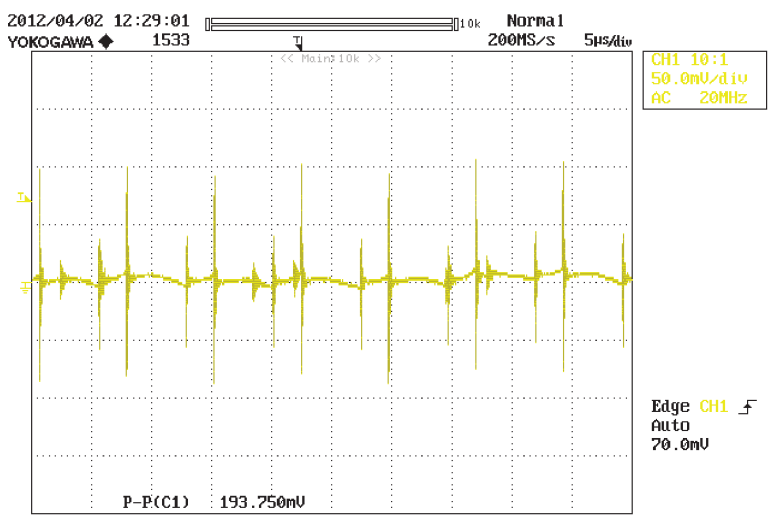

Figure 7
V1 MFA420PS48 (full load)
194 mV pk-pk ripple. 20 MHz BW



General Specifications

Characteristic	Minimum	Typical	Maximum	Units	Notes & Conditions
Efficiency		86		%	Full load (see fig. 8 & 9)
Isolation: Input to Output Input to Ground Output to Ground	3000			VAC	
	1500			VAC	
	100			VDC	
Switching Frequency: PFC Main Converter		78		kHz	
		120		kHz	
Power Density			11.1	W/in ³	
Mean Time Between Failure		420		kHrs	MIL-HDBK-217F, Notice 2 +25 °C GB
Weight			1.35 (612)	lb (g)	

Characteristic	Notes & Conditions
Signals	
AC OK/Powerfail	Open collector referenced to output 0V, transistor normally off when AC is good (see fig. 10, 16, 17 & 18) AC OK: Provides ≥ 5 ms warning of loss of output from AC failure
DC OK	Open collector referenced to 0 V, transistor normally off when DC is good (see fig. 11, 19 & 20). Provides warning of DC output failure
Remote On/Off (Inhibit/Enable)	Remotely switches outputs off, can also be configured as enable (see fig.12)
Current Share	Up to 3 supplies can be connected in parallel. Output current is shared within 10% at full load. Derate overall output current to 90% when used in parallel (see fig.13, 14 & 15)
Remote Sense	Compensates for 0.5 V total voltage drop

Efficiency Versus Load

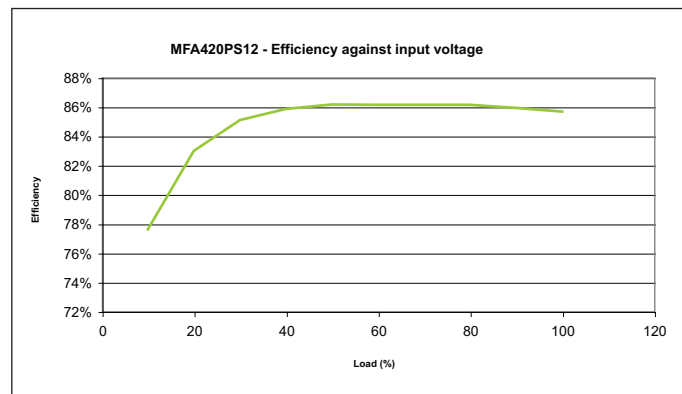

Figure 8
MFA420PS12 @ 230 VAC

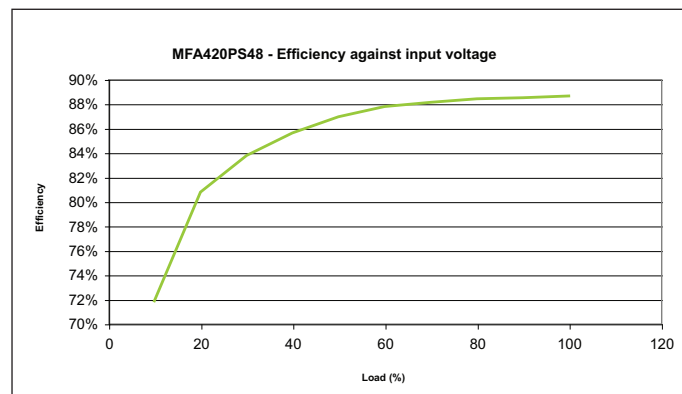
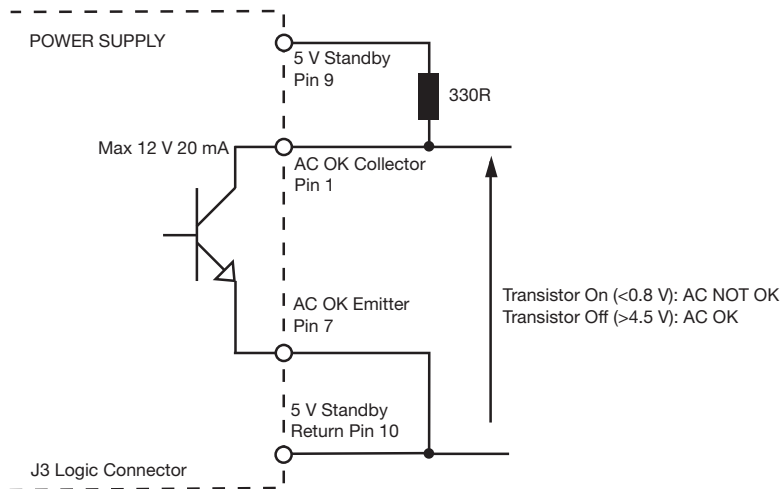

Figure 9
MFA420PS48 @ 230 VAC

Signals

AC OK/Power Fail

Figure 10



DC OK

Figure 11

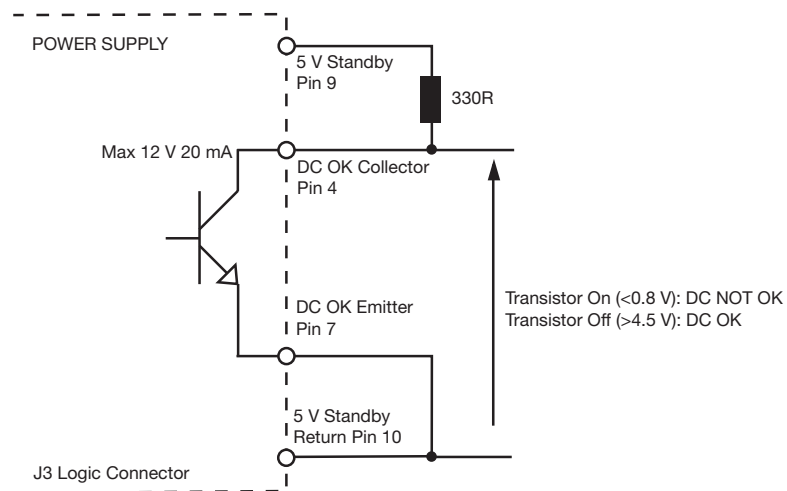

Remote On/Off (Inhibit)

Figure 12

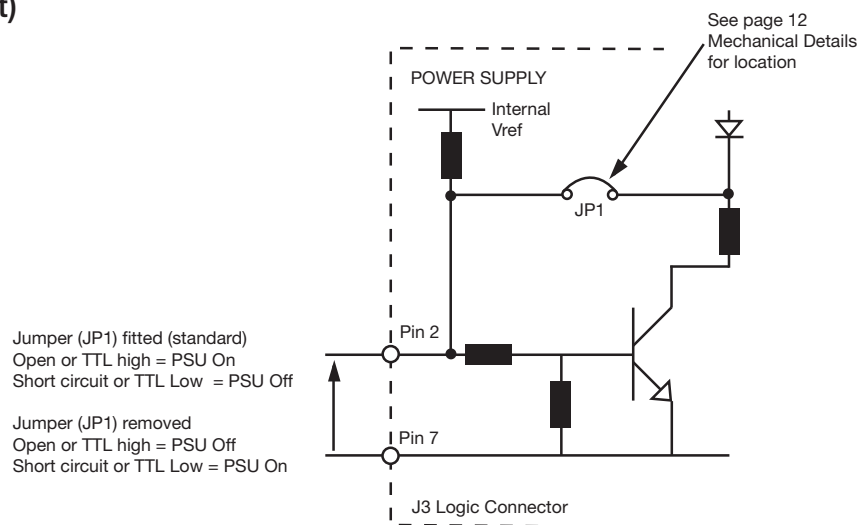

Signals

Parallel Load & Current Share Connections

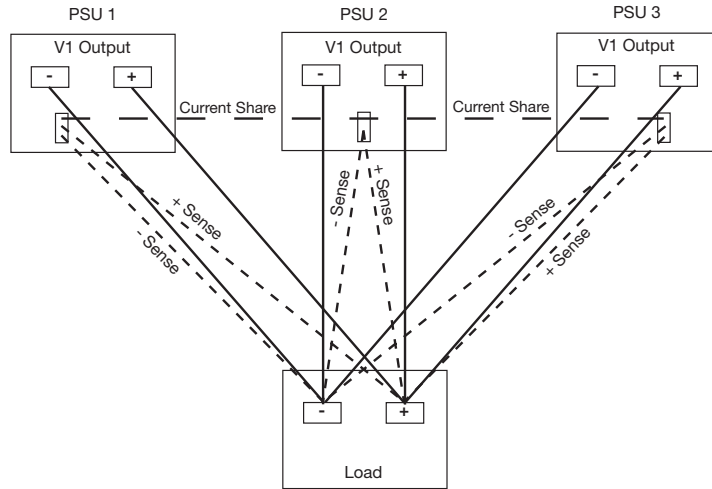

Figure 13

Parallel AC OK Connection (DC OK follows same format)

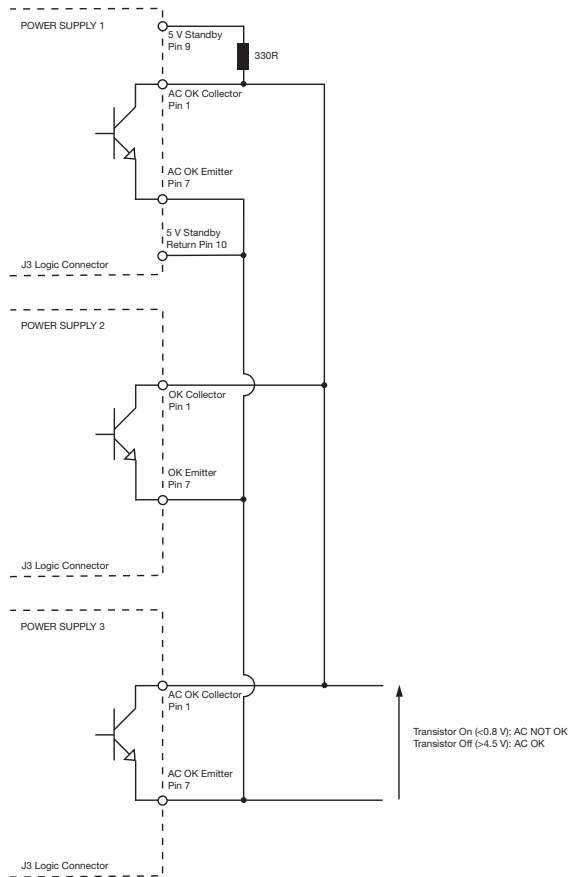

Figure 14

Parallel Remote On/Off (Inhibit) Connection

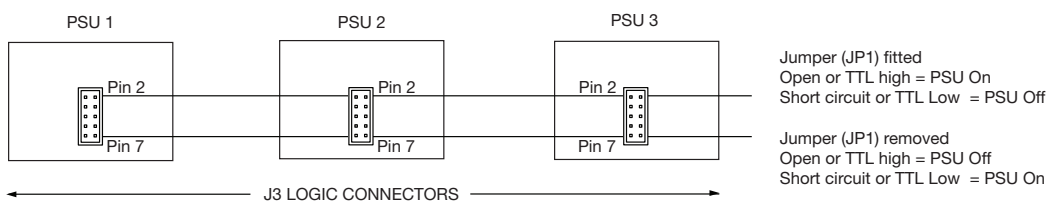

Figure 15

Signals

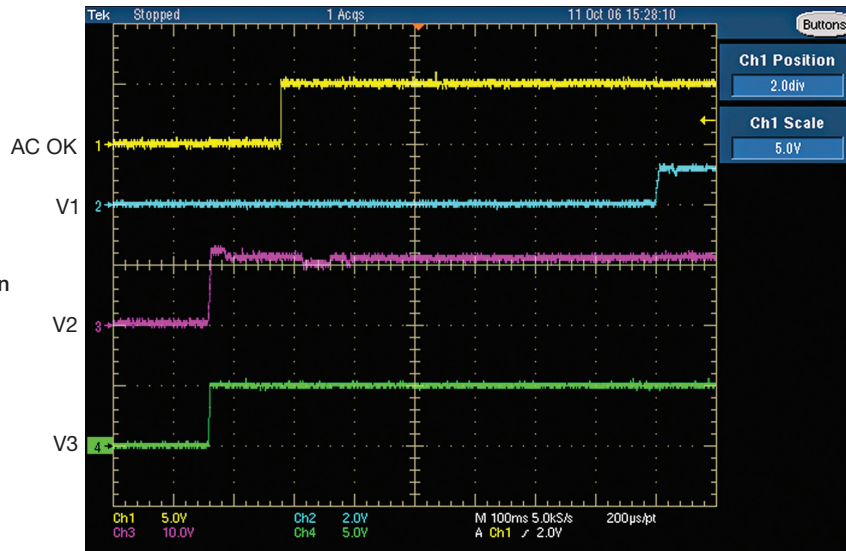

Figure 16
AC OK signal at AC switch on
(taken from MFA350PS12)

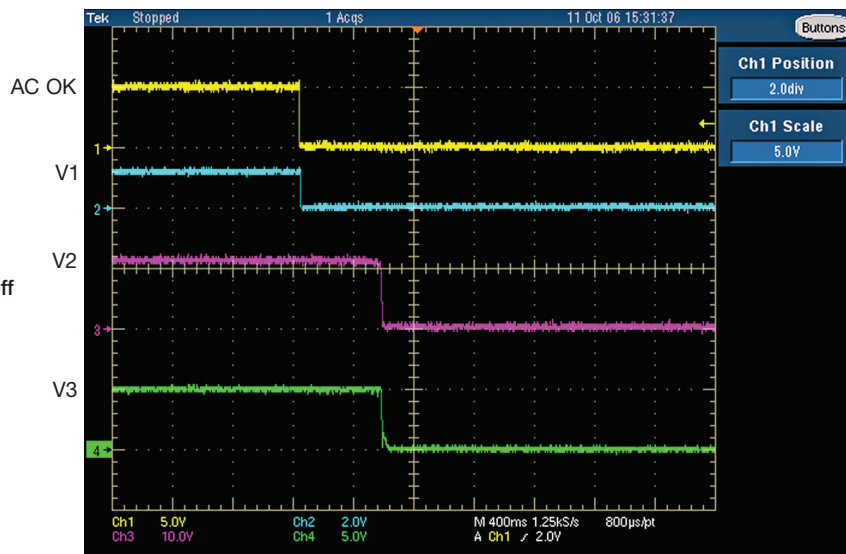

Figure 17
AC OK signal at AC switch off
(taken from MFA350PS12)

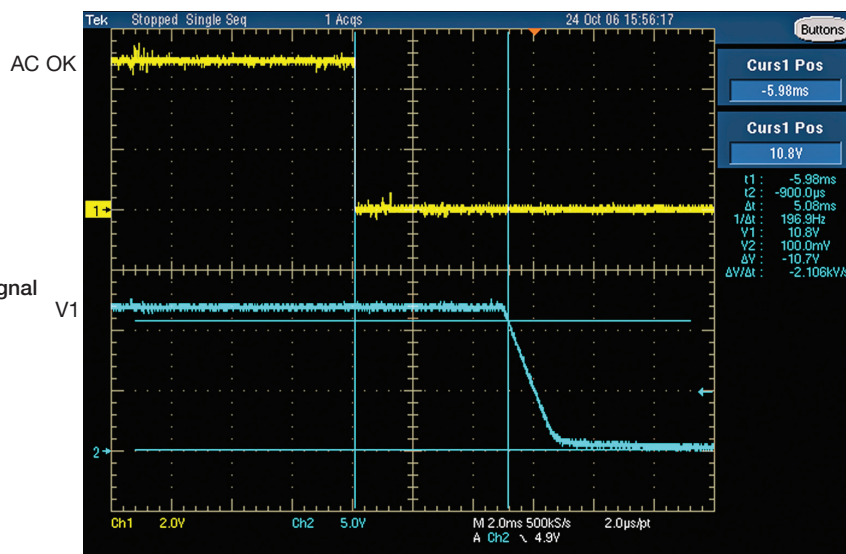

Figure 18
V1 warning time at AC OK signal
90 VAC full load
(taken from MFA350PS12)

Signals

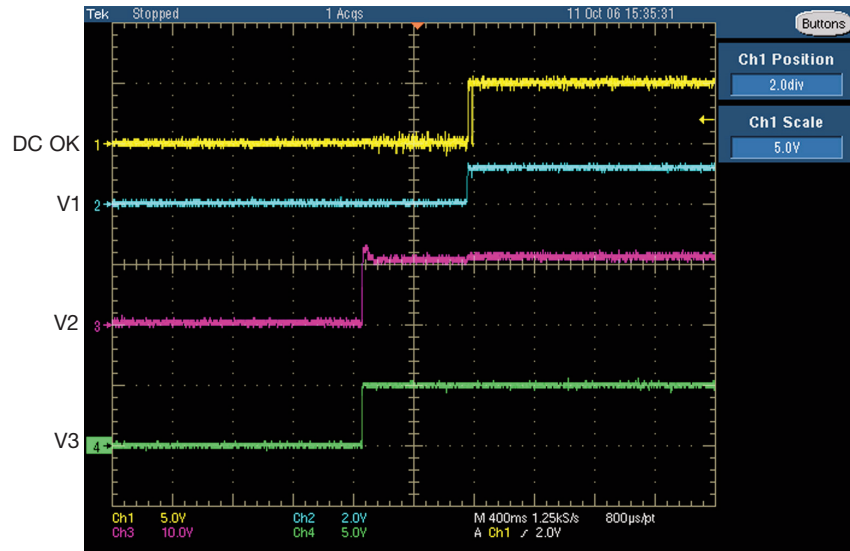

Figure 19
DC OK at AC switch on
(taken from MFA350PS12)

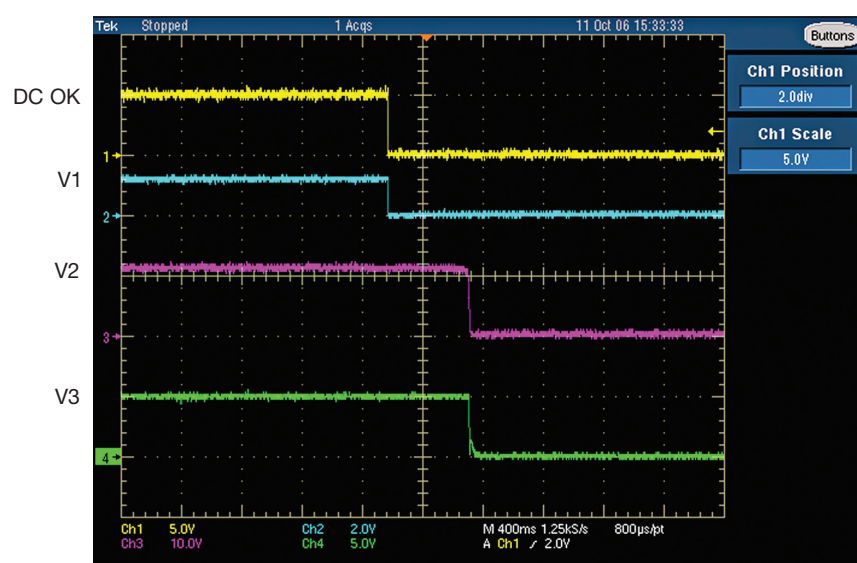

Figure 20
DC OK at AC switch off
(taken from MFA350PS12)

Environmental

Characteristic	Minimum	Typical	Maximum	Units	Notes & Conditions
Operating Temperature	-10		+70	°C	Derate linearly from +50 °C at 2.5%/°C to 50% at 70 °C when forced cooled. See Thermal Considerations.
Storage Temperature	-20		+85	°C	
Cooling	13			CFM	U Channel Version. -TF & -EF models have integral fan. See Thermal Considerations for U Channel.
Humidity	5		95	%RH	Non-condensing
Operating Altitude			3000	m	
Shock					3 x 30 g/11 ms shocks in both +ve & -ve directions along the 3 orthogonal axis, total 18 shocks.
Vibration					Single axis 10-500 Hz at 2 g x 10 sweeps

Electromagnetic Compatibility - Immunity

Phenomenon	Standard	Test Level	Criteria	Notes & Conditions
Harmonic Current	EN61000-3-2	Class A		
		Class D		
EFT	EN61000-4-4	3	A	
Surges	EN61000-4-5	Installation Class 3	A	
Magnetic Immunity	EN61000-4-8	Class 3	A	
Dips and Interruptions	EN61000-4-11	30% 10 ms	A	
		60% 100 ms	B	
		100% 5000 ms	B	

Electromagnetic Compatibility - Emissions

Phenomenon	Standard	Test Level	Criteria	Notes & Conditions
Conducted	EN55022	Class B		See fig. 21
Radiated	EN55022	Class A		
Voltage Fluctuations	EN61000-3-3			

Typical EMC Plot

Figure 21

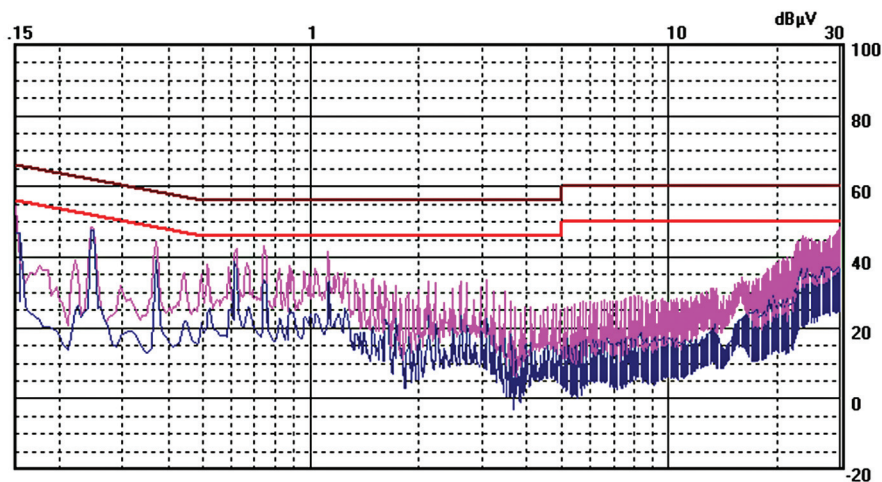

Limit #1: 55011bav Limit #2: 55011bqp Detector: Peak, Average
MFA350PS12 at full load

Safety Agency Approvals

Safety Agency	Safety Standard	Category
CB Report	UL US/14622B/UL IEC60950-1:2005 Ed. 2	Information Technology
UL	UL File #E139109 UL60950-1 (2005) 2nd Edition	Information Technology
TUV	TUV Certificate #B 1101 57396 087 EN60950-1/A11:2009	Information Technology
CE	LVD	