



Chipsmall Limited consists of a professional team with an average of over 10 year of expertise in the distribution of electronic components. Based in Hongkong, we have already established firm and mutual-benefit business relationships with customers from,Europe,America and south Asia,supplying obsolete and hard-to-find components to meet their specific needs.

With the principle of “Quality Parts,Customers Priority,Honest Operation,and Considerate Service”,our business mainly focus on the distribution of electronic components. Line cards we deal with include Microchip,ALPS,ROHM,Xilinx,Pulse,ON,Everlight and Freescale. Main products comprise IC,Modules,Potentiometer,IC Socket,Relay,Connector.Our parts cover such applications as commercial,industrial, and automotives areas.

We are looking forward to setting up business relationship with you and hope to provide you with the best service and solution. Let us make a better world for our industry!



Contact us

Tel: +86-755-8981 8866 Fax: +86-755-8427 6832

Email & Skype: info@chipsmall.com Web: www.chipsmall.com

Address: A1208, Overseas Decoration Building, #122 Zhenhua RD., Futian, Shenzhen, China



HANDLE KIT

BUL10249

REV. D

ASSEMBLY INSTRUCTIONS FOR LATCH KITS

ASSEMBLY INSTRUCTIONS

- A) MARK AND DRILL DOOR AT LOCATIONS DISPLAYED IN THE DRILLING DETAIL.
- B) MOUNT GASKET TO HANDLE (PART 1) . SLIP THREADED SHAFT THROUGH .866" (22.5mm) DIA. HOLE IN DOOR AND HOLD ONTO HANDLE. FASTEN HANDLE TO DOOR USING SCREW, WASHERS AND NUT SUPPLIED (PART 2). NOTE: HANDLE CAN BE MADE TO OPEN CLOPCKWISE OR COUNTER - CLOCKWISE BY CHANGING POSITION OF DOG LOCATED UNGER HANDLE ESCUTCHEON.
- C) SLIP SPACER (PART 4) THAT COMES WITH HANDLE OVER SHAFT.
- D) SLIP CAM (PART 3) OVER SHAFT, PINS FACING UP AND LATCH FACING OUT 90 DEGREES TO HANDLE.
- E) TIGHTEN M12 CENTER- LOCK NUT AND FLAT WASHER (PART 5) AS SHOWN.

NOTE: FOR LEFT HAND HANDLE MOUNT HARDWARE OPPOSITE.

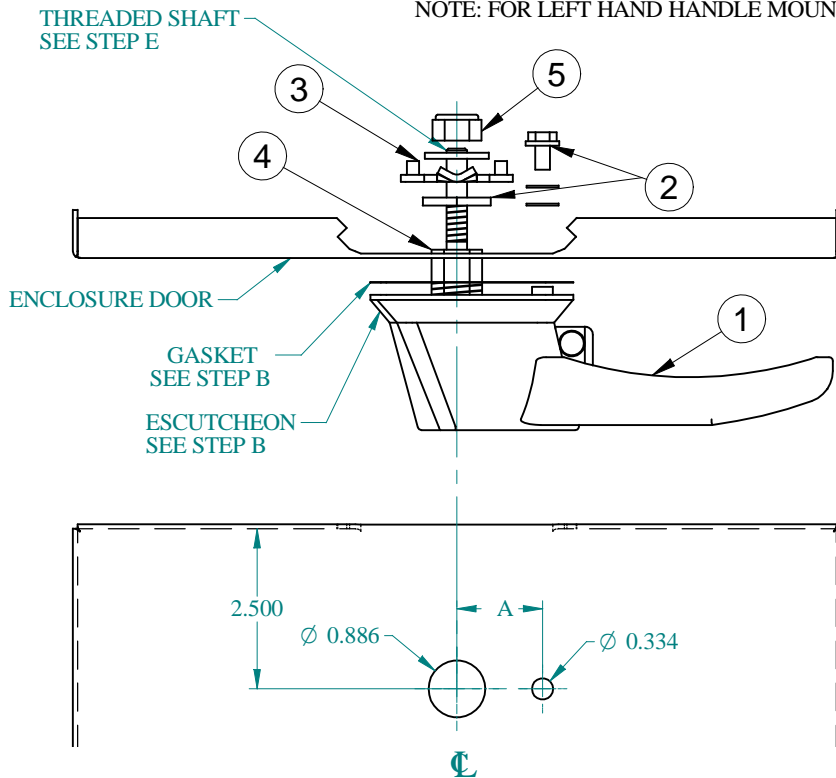

DRILLING DETAIL TOP VIEW

PHK1	8" HANDLE W/PADLOCK
PHKL1	8" HANDLE W/PADLOCK/KEYLOCK
PHKD1	8" HANDLE W/PADLOCK/DEFEATER
MHKL1	6" HANDLE W/PADLOCK/KEYLOCK
MHK1	6" HANDLE W/PADLOCK
MHKD1	6" HANDLE W/PADLOCK/DEFEATER
MHKLSS1	6" SS HANDLEW/PADLOCK/KEYLOCK
MHKSS1	6" SS HANDLE W/PADLOCK
MHKDSS1	6" SS HANDLE W/PADLOCK/DEFEATER

PART	A
6" HANDLE	1.338" (34mm)
8" HANDLE	1.417" (36mm)

PART#	QTY.	DESCRIPTION
1	1	PAD LOCKING HANDLE
2	1	HANDLE HARDWARE (SCREW, WASHERS, NUT AND GASKET)
3	1	CAM
4	1	INTERNAL SPACER
5	1	HEX NUT M10 CTR-LOCK AND FLAT WASHER

