



Chipsmall Limited consists of a professional team with an average of over 10 year of expertise in the distribution of electronic components. Based in Hongkong, we have already established firm and mutual-benefit business relationships with customers from,Europe,America and south Asia,supplying obsolete and hard-to-find components to meet their specific needs.

With the principle of "Quality Parts,Customers Priority,Honest Operation,and Considerate Service",our business mainly focus on the distribution of electronic components. Line cards we deal with include Microchip,ALPS,ROHM,Xilinx,Pulse,ON,Everlight and Freescale. Main products comprise IC,Modules,Potentiometer,IC Socket,Relay,Connector.Our parts cover such applications as commercial,industrial, and automotives areas.

We are looking forward to setting up business relationship with you and hope to provide you with the best service and solution. Let us make a better world for our industry!



Contact us

Tel: +86-755-8981 8866 Fax: +86-755-8427 6832

Email & Skype: info@chipsmall.com Web: www.chipsmall.com

Address: A1208, Overseas Decoration Building, #122 Zhenhua RD., Futian, Shenzhen, China



General Description

The Micrel MIC2204 is a high-efficiency, 2MHz PWM synchronous buck switching regulator. Power conversion efficiency of above 95% is easily obtainable over a wide range of applications. A proprietary internal compensation technique ensures stability with the smallest possible inductor and ceramic output capacitor.

The MIC2204 operates from 2.3V to 5.5V input and features internal power MOSFETs that can supply over 600mA of output current with output voltages down to 1V. The MIC2204 implements a constant 2MHz pulse-width-modulation (PWM) control scheme which reduces spurious noise in sensitive RF and communication applications. Additionally, the MIC2204 can be synchronized to an external clock, or multiple MIC2204s can easily be daisy-chained with the SYNCLOCK feature.

The MIC2204 has a high bandwidth loop (typ. 200kHz) which allows ultra-fast transient response times. This is very useful when powering applications that require fast dynamic responses, such as the CPU cores and RF circuitry in high-performance cellular phones and PDAs.

The MIC2204 is available in 10-pin MSOP and 3mm × 3mm MLF™-10L package options with an operating junction temperature range from -40°C to 125°C .

Features

- Input voltage range: 2.3V to 5.5V
- Output down to 1V/ 600mA
- 2MHz PWM operation
- Ultra-fast transient response (typical 200kHz GBW)
- Internal compensation
- All ceramic capacitors
- >95% efficiency
- Fully integrated MOSFET switches
- Easily synchronized to external clock
- SYNCLOCK feature to daisy-chain multiple 2204s
- <340µA quiescent current
- Logic controlled micropower shutdown
- Thermal shutdown and current limit protection
- 10-pin MSOP and 3mm×3mm MLF™-10L
- -40°C to +125°C junction temperature range

Applications

- High-efficiency portable power
- Cellular phones
- PDAs
- 802.11 WLAN power supplies
- RF power supplies
- Li Ion battery powered applications

Typical Application

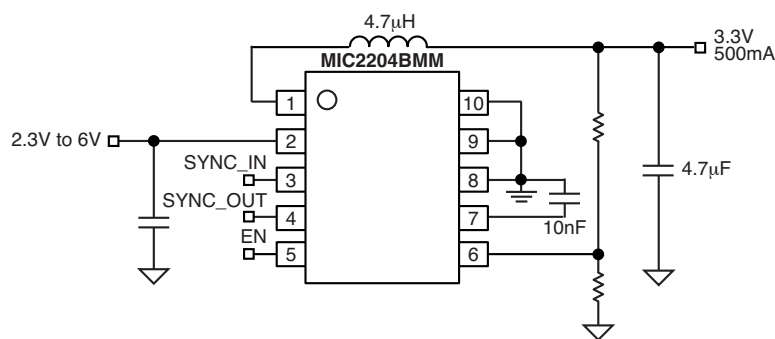

Adjustable Output Synchronous Buck Converter

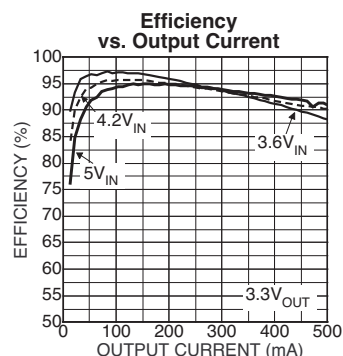

Ordering Information

Part Number	Voltage	Junction Temp. Range	Package	Lead Finish
MIC2204BMM	Adjustable	-40°C to +125°C	10-pin MSOP	Standard
MIC2204YMM	Adjustable	-40°C to +125°C	10-pin MSOP	Lead-Free
MIC2204BML	Adjustable	-40°C to +125°C	10-pin MLF™	Standard
MIC2204YML	Adjustable	-40°C to +125°C	10-pin MLF™	Lead-Free

Pin Configuration

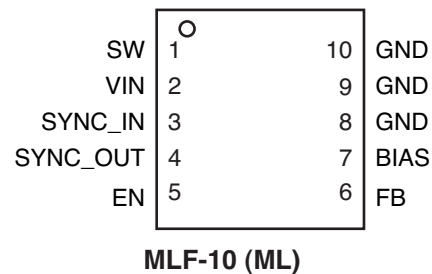
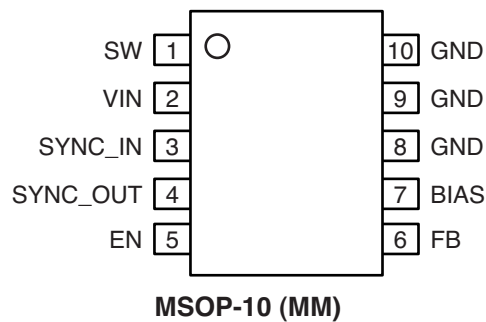

Pin Description

Pin Number	Pin Name	Pin Function
1	SW	Switch (Output): Internal power MOSFET output switches.
2	VIN	Supply Voltage (Input): Requires bypass capacitor to GND.
3	SYNC_IN	SYNC_IN for the MIC2204: Sync the main switching frequency to an external clock. Tie pin to ground if not using this function. Tying SYNC_IN high reduces the switching frequency to 1.6MHz (See “Applications Information” section).
4	SYNC_OUT	SYNC_OUT an open collector output to feed into SYNC_IN. Float or ground the SYNC_OUT pin if not using sync out function.
5	EN	A low level EN will power down the device, reducing the quiescent current to under 15µA (typ. 6.5µA).
6	FB	Input to the error amplifier, connect to the external resistor divider network to set the output voltage.
7	BIAS	Internal circuit bias supply, nominally 2.3V. Must be de-coupled to signal ground with a 0.01µF capacitor.
8, 9, 10	GND	Ground.

Absolute Maximum Ratings⁽¹⁾

Supply Voltage (V_{IN})	6V
Output Switch Voltage (V_{SW})	6V
Logic Input Voltage (V_{EN}, V_{SYNC_IN})	V_{IN} to $-0.3V$
Power Dissipation ⁽²⁾	
Storage Temperature (T_S)	$-65^{\circ}C$ to $+150^{\circ}C$

Operating Ratings⁽³⁾

Supply Voltage (V_{IN})	$+2.3V$ to $+5.5V$
Junction Temperature (T_J)	$-40^{\circ}C \leq T_J \leq +125^{\circ}C$
Package Thermal Resistance	
MSOP (θ_{JA})	$115^{\circ}C/W$
3mm×3mm MLF™-10L (θ_{JA})	$60^{\circ}C/W$

Electrical Characteristics⁽⁴⁾

$T_A = 25^{\circ}C$ with $V_{IN} = V_{EN} = 3.5V$, unless otherwise noted. **Bold** values indicate $-40^{\circ}C < T_J < +125^{\circ}C$

Parameter	Condition	Min	Typ	Max	Units
Supply Voltage Range		2.3		5.5	V
Current Limit	$V_{FB} = 0.7V$	0.6	1.2	2	A
Quiescent Current	$V_{FB} = 1.1V$		320	450	μA
	$EN = 0V$		6.0	15	μA
Feedback Voltage		0.98	1.0	1.02	V
Output Voltage Line Regulation	$V_{OUT} = 1V, V_{IN} = 2.3V$ to $5.5V, I_{LOAD} = 100mA$		0.2		%
Output Voltage Load Regulation	$0mA < I_{LOAD} < 500mA$		0.2		%
Maximum Duty Cycle	$V_{FB} = 0.7V$	100			%
Switch On-Resistance	$I_{SW} = 300mA, V_{FB} = 0.7V$		0.72		Ω
	$I_{SW} = -300mA, V_{FB} = 1.1V$		0.55		Ω
Oscillator Frequency		1.8	2	2.2	MHz
Sync Frequency Range		1.8		2.5	MHz
SYNC_IN Threshold			1.2		V
Sync Minimum Pulse Width			10		ns
SYNC_IN Input Current			1	2	μA
Enable Threshold		0.52	0.72	0.96	V
Enable Hysteresis			20		mV
Enable Input Current			1	2	μA
Overtemperature Shutdown			160		$^{\circ}C$
Overtemperature Shutdown Hysteresis			20		$^{\circ}C$

Notes:

1. Exceeding the ABSOLUTE MAXIMUM RATINGS may damage device.
2. Absolute maximum power dissipation is limited by maximum junction temperature where $P_{D(MAX)} = (T_{J(MAX)} - T_A) \div \theta_{JA}$.
3. The device is not guaranteed to function outside its operating rating.
4. Specification for packaged product only.

Typical Characteristics

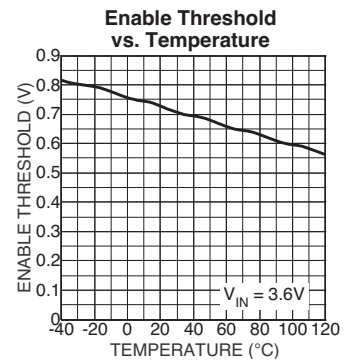
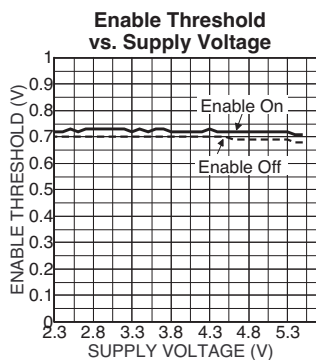
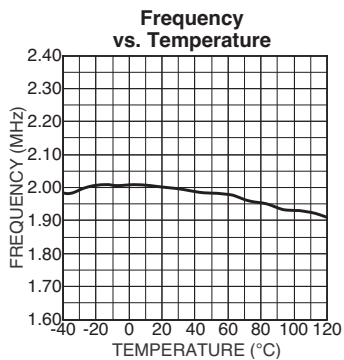
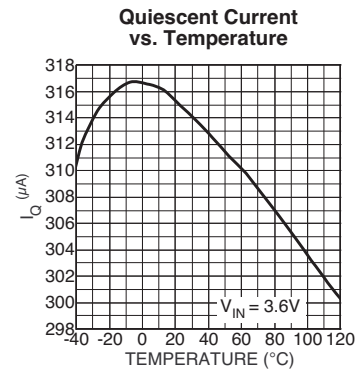
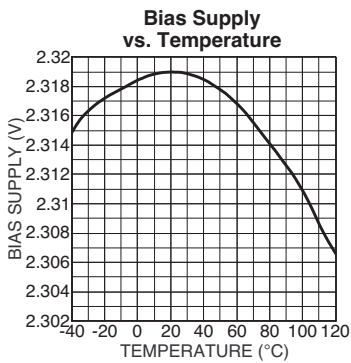
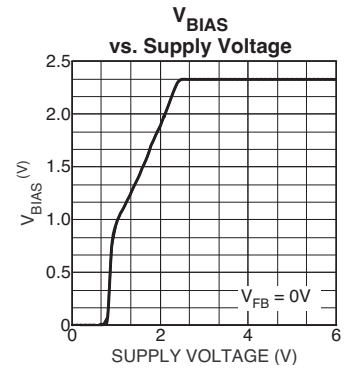
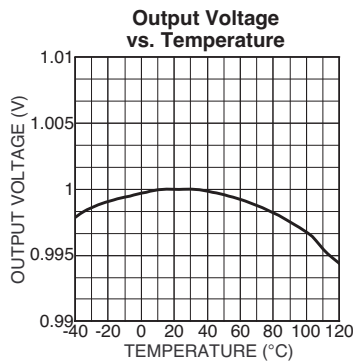
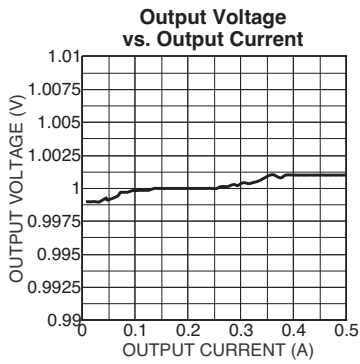
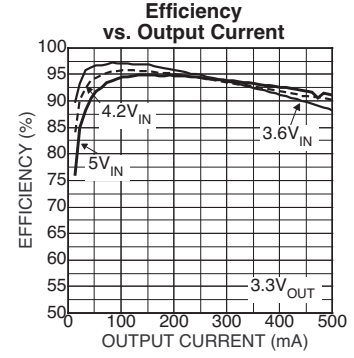
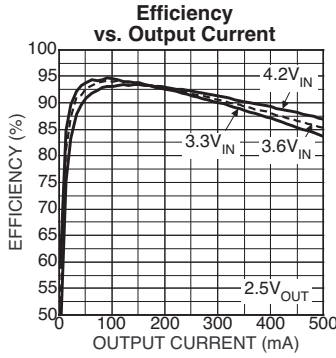
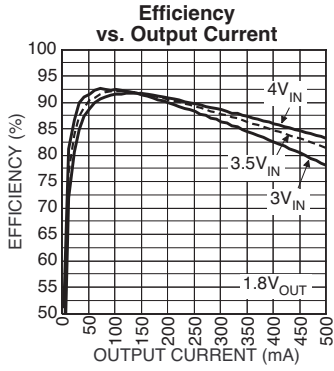

Functional Characteristics

Enable Transient

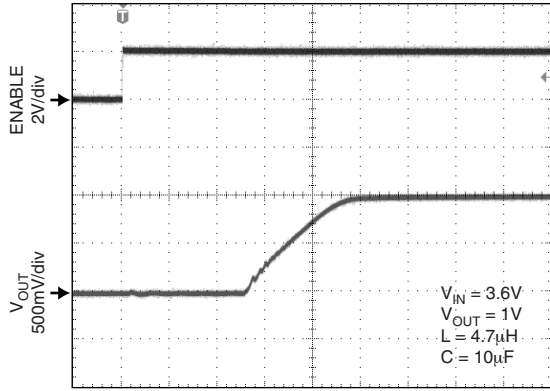

Disable Transient

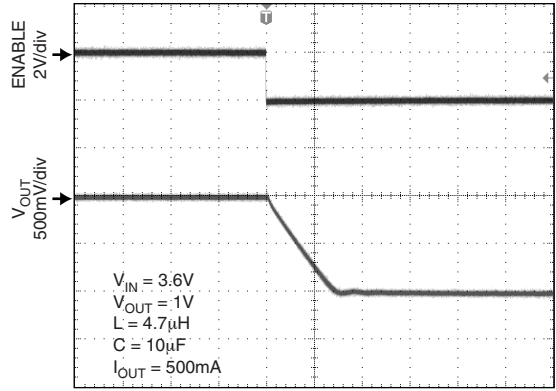

Line Transient

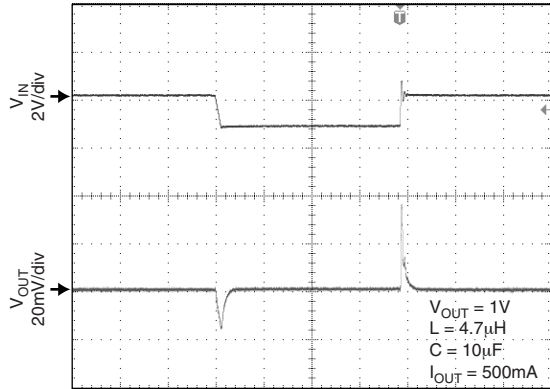

Load Transient

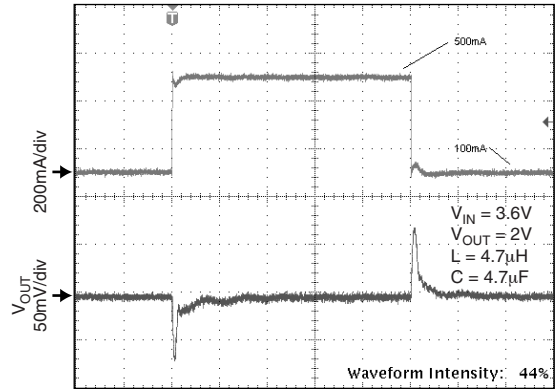

Switch Node Output Ripple

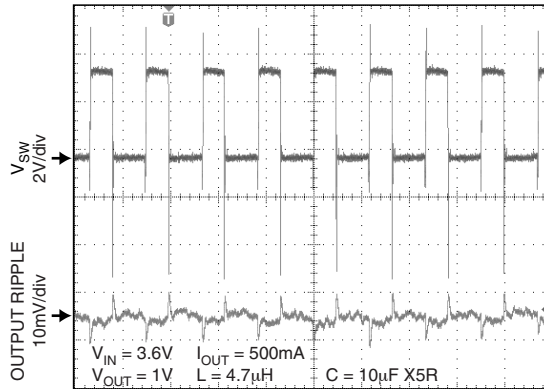

Block Diagram

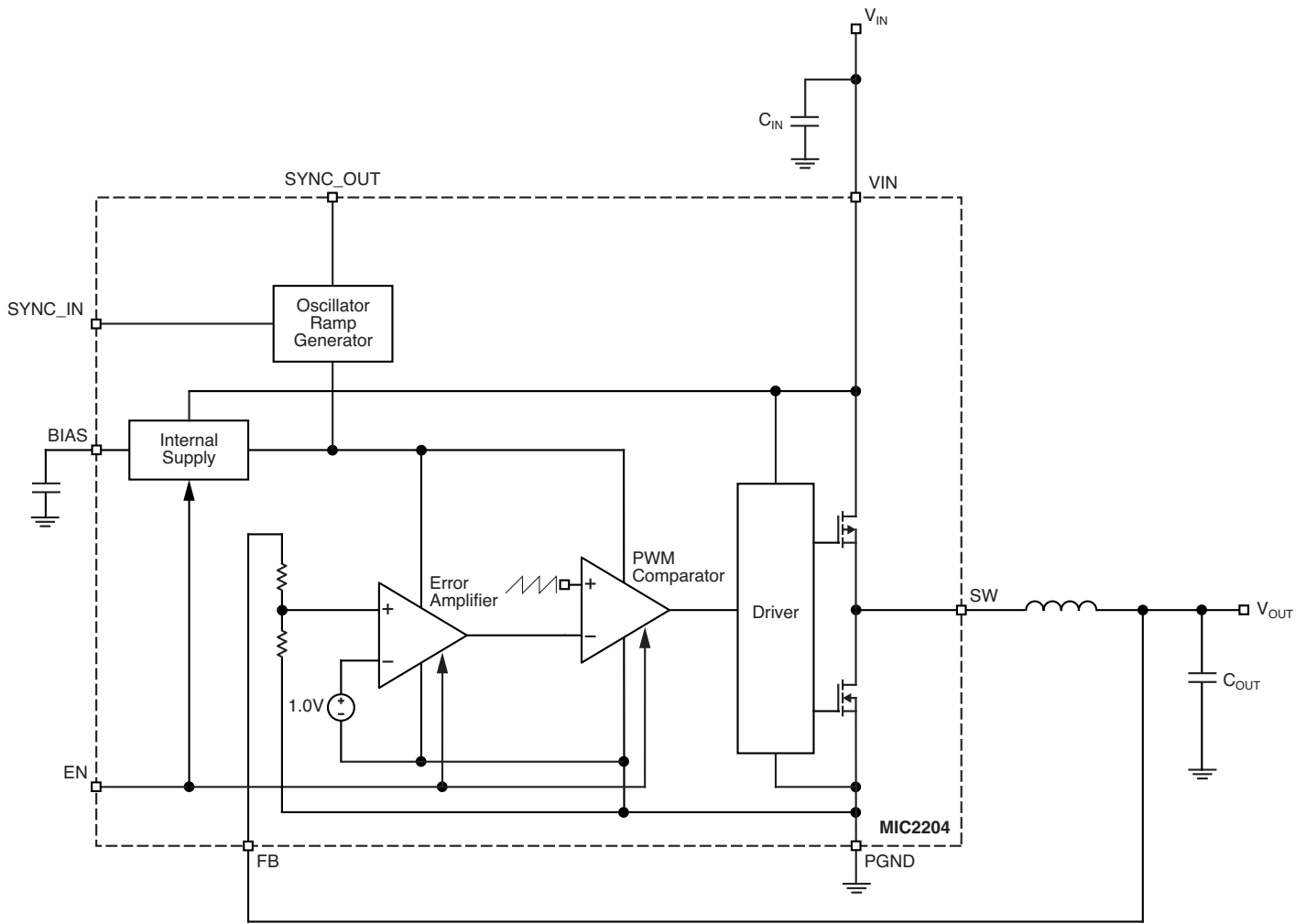

MIC2204 Block Diagram

Functional Description

VIN

VIN provides power to the output and to the internal bias supply. The supply voltage range is from 2.3V to 5.5V. A minimum 1 μ F ceramic is recommended for bypassing the input supply.

Enable

The enable pin provides a logic level control of the output. In the off state, supply current of the device is greatly reduced (typically 6.5 μ A). Also, in the off state, the output drive is placed in a “tri-stated” condition, where both the high-side P-Channel MOSFET and the low-side N-Channel are in an off or non-conducting state. Do not drive the enable pin above the supply voltage.

SYNC_IN

SYNC_IN enables the ability to change the fundamental switching frequency. The SYNC_IN frequency has a minimum frequency of 1.8MHz and a maximum sync frequency of 2.5MHz.

Careful attention should be paid to not driving the SYNC_IN pin greater than the supply voltage. While this will not damage the device, it will cause improper operation.

SYNC_OUT

Since SYNC_OUT is an open collector output that provides a signal equal to the internal oscillator frequency, multiple MIC2204s to be connected together in a master-slave configuration for frequency matching of the converters. A typical 10k Ω is recommended for a pull-up resistor.

BIAS

The bias supply is an internal 2.3V linear regulator that supplies the internal biasing voltage to the MIC2204. A 10nF ceramic capacitor is required on this pin for bypassing. Do not use the BIAS pin as a supply. The BIAS pin was designed to supply internal power and not external circuitry.

Feedback

The feedback pin provides the control path to control the output. A resistor divider connecting the feedback to the output is used to adjust the desired output voltage. Refer to the “Feedback” material in the “Applications Information” section for more detail.

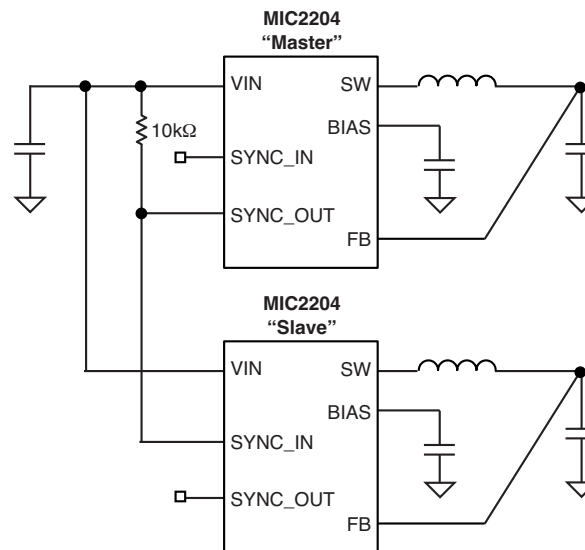

Figure 1. SYNC_OUT

Applications Information

Input Capacitor

A minimum 1 μ F ceramic is recommended on the VIN pin for bypassing. X5R or X7R dielectrics are recommended for the input capacitor. Y5V dielectrics are not recommended: they lose most of their capacitance over temperature and also become resistive at high frequencies. This reduces their ability to filter out high frequency noise.

Output Capacitor

The MIC2204 was designed specifically for the use of a 4.7 μ F ceramic output capacitor. The output capacitor requires either an X7R or X5R dielectric. Y5V and Z5U dielectric capacitors, aside from the undesirable effect of their wide variation in capacitance over temperature, become resistive at high frequencies. Using Y5V or Z5U capacitors will cause instability in the MIC2204. For output voltages less than 1.6V, a 10 μ F capacitor may be required for stability. See the "Compensation" section for more detail.

Total output capacitance should not exceed 15 μ F. Large values of capacitance can cause current limit to engage during start-up. If larger than 15 μ F is required, a feed-forward capacitor from the output to the feedback node should be used to slow the start-up time.

Inductor Selection

Inductor selection will be determined by the following (not necessarily in the order of importance):

- Inductance
- Rated current value
- Size requirements
- DC resistance (DCR)

The MIC2204 is designed for use with a 4.7 μ H inductor.

Maximum current ratings of the inductor are generally given in two methods: permissible DC current and saturation current. Permissible DC current can be rated either for a 40°C temperature rise or a 10% loss in inductance. Ensure the inductor selected can handle the maximum operating current. When saturation current is specified, make sure that there is enough margin that the peak current will not saturate the inductor.

The size requirements refer to the area and height requirements that are necessary to fit a particular design. Please refer to the inductor dimensions on their data sheet.

DC resistance is also important. While DCR is inversely proportional to size, DCR can represent a significant efficiency loss. Refer to the "Efficiency Considerations" below for a more detailed description.

Table 1 below shows a list of recommended 4.7 μ H inductors by manufacturer, part number and key specifications.

Bias Capacitor

A small 10nF ceramic capacitor is required to bypass the BIAS pin. The use of low ESR ceramics provides improved filtering for the bias supply.

Efficiency Considerations

Efficiency is defined as the amount of useful output power, divided by the amount of power consumed.

$$\text{Efficiency \%} = \left(\frac{V_{\text{OUT}} \times I_{\text{OUT}}}{V_{\text{IN}} \times I_{\text{IN}}} \right) \times 100$$

Maintaining high-efficiency serves two purposes. It reduces power dissipation in the power supply, reducing the need for heat sinks and thermal design considerations and it reduces consumption of current for battery powered applications. Reduced current draw from a battery increases the devices operating time, critical in handheld devices.

There are two loss terms in switching converters: DC losses and switching losses. DC losses are simply the power dissipation of I^2R . For example, power is dissipated in the high-side switch during the on cycle, where power loss is equal to the high-side MOSFET $R_{\text{DS(ON)}}$ multiplied by the Switch Current². During the off cycle, the low-side N-Channel MOSFET conducts, also dissipating power. Device operating current also reduces efficiency. The product of the quiescent (operating) current and the supply voltage is another DC loss. The current required to drive the gates on and off at a constant 2MHz frequency and the switching transitions make up the switching losses.

Manufacturer	P/N	H(mm)	W(mm)	L(mm)	DCR(m Ω)
Sumida	CDRH2D18-4R7	2	3.2	3.2	81
Murata	LQH43CN4R7M01	2.6	3.2	4.6	150
Murata	LQH32CN4R7M11	2.2	2.7	3.4	195
Coilcraft	1008PS-472M	2.74	3.8	3.8	350
Low Profile					
TDK	LDR5610T-4R7MR90	1	5.2	5.8	240
Sumida	CMD4D06	0.8	6.3	5.8	216

Table 1. Component Selection Table

Figure 2 shows an efficiency curve. On the non-shaded portion, from 0 to 200mA, efficiency losses are dominated by quiescent current losses, gate drive and transition losses. In this case, lower supply voltages yield greater efficiency in that they require less current to drive the MOSFETs and have reduced input power consumption.

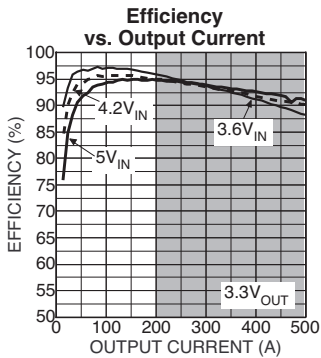

Figure 2.

On the shaded region, 200mA to 500mA, efficiency loss is dominated by MOSFET R_{DSON} and inductor losses. Higher input supply voltages will increase the Gate-to-Source threshold on the internal MOSFETs, reducing the internal R_{DSON} . This improves efficiency by reducing DC losses in the device. All but the inductor losses are inherent to the device, making inductor selection even more critical in efficiency calculations. As the inductors are reduced in size, the DC resistance (DCR) can become quite significant. The DCR losses can be calculated as follows:

$$L_{PD} = I_{OUT}^2 \times DCR$$

From that, the loss in efficiency due to inductor resistance can be calculated as follows:

$$\text{Efficiency Loss} = \left[1 \pm \left(\frac{V_{OUT} \times I_{OUT}}{V_{OUT} \times I_{OUT} + L_{PD}} \right) \right] \times 100$$

Efficiency loss due to DCR is minimal at light loads and gains significance as the load is increased. Inductor selection becomes a trade-off between efficiency and size in this case.

Compensation

The MIC2204 is an internally compensated, voltage-mode buck regulator. Voltage mode is achieved by creating an internal 2MHz ramp signal and using the output of the error amplifier to pulsewidth modulate the switch node, maintain-

ing output voltage regulation. With a typical gain bandwidth of 200kHz, the MIC2204 is capable of extremely fast transient responses.

The MIC2204 is designed to be stable with a 4.7 μ H inductor and a 4.7 μ F ceramic (X5R) output capacitor for output voltages greater than 1.6V. For output voltages less than 1.6V, a 10 μ F capacitor is required. Also, when a feed forward capacitor is used, the gain bandwidth is increased to unity gain. This will also require increasing the output capacitor to 10 μ F.

Feedback

The MIC2204 provides a feedback pin to adjust the output voltage to the desired level. This pin connects internally to an error amplifier. The error amplifier then compares the voltage at the feedback to the internal 1V reference voltage and adjusts the output voltage to maintain regulation. To calculate the resistor divider network for the desired output is as follows:

$$R2 = \frac{R1}{\left(\frac{V_{OUT}}{V_{REF}} \pm 1 \right)}$$

Where V_{REF} is 1.0V and V_{OUT} is the desired output voltage.

A 10k Ω or lower resistor value from the output to the feedback is recommended. Larger resistor values require an additional capacitor (feed-forward) from the output to the feedback. The large high-side resistor value and the parasitic capacitance on the feedback pin (~10pF) can cause an additional pole in the loop. The additional pole can create a phase loss at high-frequency. This phase loss degrades transient response by reducing phase margin. Adding feed-forward capacitance negates the parasitic capacitive effects of the feedback pin. A minimum 1000pF capacitor is recommended for feed-forward capacitance.

Also, large feedback resistor values increase the impedance, making the feedback node more susceptible to noise pick-up. A feed-forward capacitor would also reduce noise pick-up by providing a low impedance path to the output.

When using a feed-forward capacitor, the gain bandwidth of the device reaches unity gain at high-frequency. Therefore, output capacitance will need to be increased to a minimum 10 μ F. For more information on output capacitor selection for stability, see the "Compensation" section.

PWM Operation

The MIC2204 is a pulsewidth modulation (PWM) controller. By controlling the ratio of on-to-off time, or duty cycle, a regulated DC output voltage is achieved. As load or supply voltage changes, so does the duty cycle to maintain a constant output voltage. In cases where the input supply runs into a dropout condition, the MIC2204 will run at 100% duty cycle.

The MIC2204 provides constant switching at 2MHz with synchronous internal MOSFETs. The internal MOSFETs include a high-side P-Channel MOSFET from the input supply to the switch pin and an N-Channel MOSFET from the switch pin to ground. Since the low-side N-Channel MOSFET provides the current during the off cycle, a free wheeling Schottky diode from the switch node to ground is not required.

PWM control provides fixed frequency operation. By maintaining a constant switching frequency, predictable fundamental and harmonic frequencies are achieved. Other methods of regulation, such as burst and skip modes, have frequency spectrums that change with load and can interfere with sensitive communication equipment.

Synchronization

SYNC_IN allows the user to change the frequency from 2MHz up to 2.5MHz or down to 1.8MHz. This controls the fundamental frequency and all the resultant harmonics. Maintaining a predictable frequency creates the ability to either shift the harmonics away from sensitive carrier and IF frequency bands, or to accurately filter out specific harmonic frequencies.

Connecting the SYNC_OUT function pin to the SYNC_IN of other MIC2204s will synchronize multiple MIC2204s in a daisy-chain. Synchronizing multiple MIC2204s means that regulators will run at the same fundamental frequency, resulting in matched harmonic frequencies and simplifying design for sensitive communication equipment.

Package Information

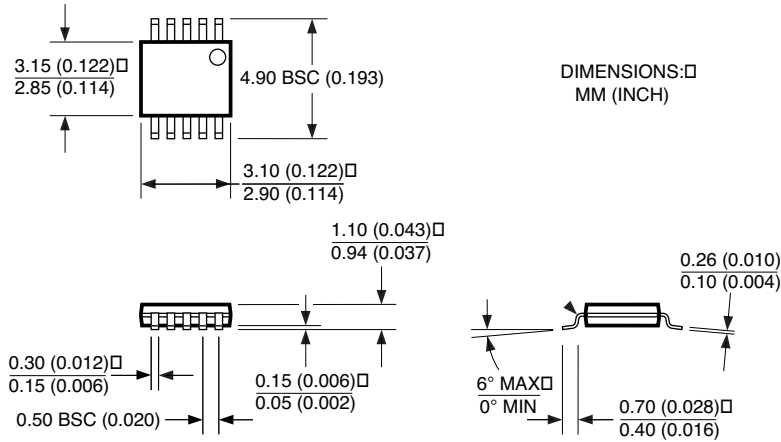

10-Pin MSOP (MM)

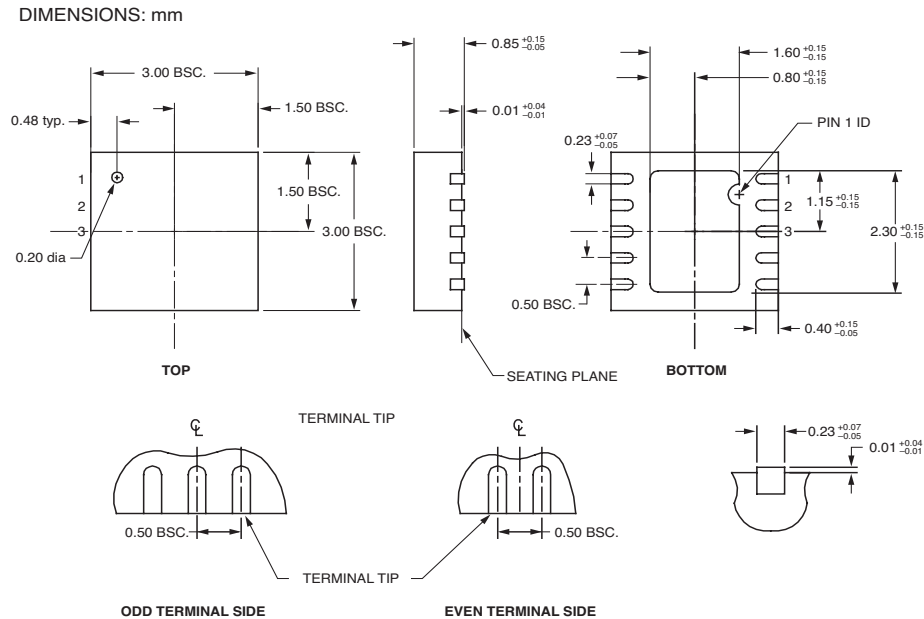

10-Pin MLF™ (ML)

MICREL INC. 2180 FORTUNE DRIVE SAN JOSE, CA 95131 USA

TEL + 1 (408) 944-0800 FAX + 1 (408) 474-1000 WEB <http://www.micrel.com>

This information furnished by Micrel in this data sheet is believed to be accurate and reliable. However no responsibility is assumed by Micrel for its use. Micrel reserves the right to change circuitry and specifications at any time without notification to the customer.

Micrel Products are not designed or authorized for use as components in life support appliances, devices or systems where malfunction of a product can reasonably be expected to result in personal injury. Life support devices or systems are devices or systems that (a) are intended for surgical implant into the body or (b) support or sustain life, and whose failure to perform can be reasonably expected to result in a significant injury to the user. A Purchaser's use or sale of Micrel Products for use in life support appliances, devices or systems is a Purchaser's own risk and Purchaser agrees to fully indemnify Micrel for any damages resulting from such use or sale.

© 2004 Micrel, Incorporated.