



Chipsmall Limited consists of a professional team with an average of over 10 year of expertise in the distribution of electronic components. Based in Hongkong, we have already established firm and mutual-benefit business relationships with customers from,Europe,America and south Asia,supplying obsolete and hard-to-find components to meet their specific needs.

With the principle of "Quality Parts,Customers Priority,Honest Operation,and Considerate Service",our business mainly focus on the distribution of electronic components. Line cards we deal with include Microchip,ALPS,ROHM,Xilinx,Pulse,ON,Everlight and Freescale. Main products comprise IC,Modules,Potentiometer,IC Socket,Relay,Connector.Our parts cover such applications as commercial,industrial, and automotives areas.

We are looking forward to setting up business relationship with you and hope to provide you with the best service and solution. Let us make a better world for our industry!



Contact us

Tel: +86-755-8981 8866 Fax: +86-755-8427 6832

Email & Skype: info@chipsmall.com Web: www.chipsmall.com

Address: A1208, Overseas Decoration Building, #122 Zhenhua RD., Futian, Shenzhen, China





MIC23158/9 Evaluation Board

3MHz, PWM, Dual 2A Buck Regulator with HyperLight Load[®] and Power Good

General Description

This board enables the evaluation of the MIC23158, a fully-integrated 2A, 3MHz, dual switching regulators featuring HyperLight Load[®] mode, power good output indicator, and programmable soft-start. The MIC23158 is highly efficient throughout the entire output current range, drawing just 45 μ A of quiescent current for both outputs in operation. The 3mm \times 4mm MLF[®] package, in combination with the 3MHz switching frequency, enables a compact sub-1mm height solution. The MIC23158 provides accurate output voltage regulation under the most demanding conditions and responds extremely quickly to a load transient with exceptionally small output voltage ripple.

Requirements

This board requires a single 15W bench power source adjustable from 2.7V to 5.5V. The loads can either be active (electronic load) or passive (resistor) with the capability to dissipate 7W. It is ideal to have an oscilloscope available to view the circuit waveforms, but not essential. For the simplest tests, three voltage meters are required to measure input and two output voltages. For efficiency measurements, three voltage meters and three ammeters are required to prevent errors due to measurement inaccuracies.

Precautions

There is no reverse input protection on this board, therefore caution is advised when connecting the input source to ensure correct polarity is observed.

Evaluating the MIC23159YML

The MIC23159YML provides an auto discharge feature that switches in a 225 Ω pull down circuit on its output to discharge the output capacitor when disabled. The evaluation board can be easily modified by interchanging the MIC23158 device with MIC23159.

Datasheets and support documentation are available on Micrel's web site at: www.micrel.com.

Getting Started

1. Connect an external supply to the VIN (J1 or J5) and GND terminals.

With the output of the power supply disabled, set its voltage to the desired input test voltage ($2.7V \leq V_{IN} \leq 5.5V$). An ammeter may be placed between the input supply and the V_{IN} (J1 or J5) terminal. Be sure to monitor the supply voltage at the V_{IN} (J1 or J5) terminal, as the ammeter and/or power lead resistance can reduce the voltage supplied to the device..

2. Connect a load to the VOUT (J2 and J6) and GND terminals.

The load can be either passive (resistive) or active (electronic load). An ammeter may be placed between the load and the output terminals. Ensure the output voltage is monitored at the VOUT (J2 and J6) terminals.

3. Enable the MIC23158 (J9 and J10).

The MIC23158 evaluation board has a pull-up resistor to VIN. By default, the output voltage will be enabled when the input supply of >2.7V is applied. To disable the device, apply a voltage below 0.4V to the EN terminals.

4. Power Good (J11 and J12).

A power good test point is provided to monitor the power good function. The power good output will go high approximately 70 μ s after the output voltage reaches 90% of its nominal voltage.

Ordering Information

Part Number	Description
MIC23158YML EV	Adjustable Output Evaluation Board ($V_{OUT1} = 1.8V$, $V_{OUT2} = 1.5V$)

HyperLight Load is a registered trademark of Micrel, Inc.

MLF and MicroLeadFrame are trademarks of Amkor Technology, Inc.

Micrel Inc. • 2180 Fortune Drive • San Jose, CA 95131 • USA • tel +1 (408) 944-0800 • fax + 1 (408) 474-1000 • <http://www.micrel.com>

February 4, 2013

Revision 1.0

Evaluation Board

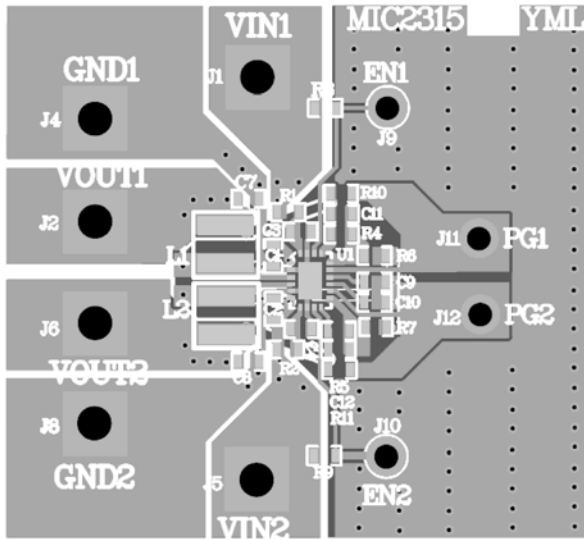

Features

Soft-Start Capacitors (C9 and C10)

The MIC23158 has a nominal 296kΩ resistor charging the capacitor on the SS pin. This enables the output to follow a controlled soft start characteristic. Setting C9 and C10 to 470pF sets the startup time to approximately 320μs. The start-up time can be determined by Equation 1:

$$T_{SS} = 296 \times 10^3 \times \ln(10) \times C_{SS} \quad \text{Eq. 1}$$

The action of the soft-start capacitor is to control the rise time of the internal reference voltage between 0% and 100% of its nominal steady state value.

Feedback Resistors (R4, R5, R6, and R7) for Adjustable Outputs

The output voltages are set nominally to 1.8V and 1.5V. These outputs can be changed by adjusting the upper resistor, R4 and R5, in the feedback potential divider. Therefore:

$$R4 = R6 \times (V_O - V_{REF}) / V_{REF}$$

$$R5 = R7 \times (V_O - V_{REF}) / V_{REF}$$

where $V_{REF} = 0.62V$.

Some example values are shown in [Table 1](#):

Table 1. Feedback Resistor Values for Adjustable Outputs

V _{OUT}	R4 and R5	R6 and R7
1.2V	274k	294k
1.5V	316k	221k
1.8V	301k	158k
2.5V	324k	107k
3.3V	309k	71.5k

The feed-forward capacitors (C11 and C12) are typically not fitted. The transient performance can be improved slightly by fitting a capacitor at C11 and C12 to inject fast output voltage deviations directly into the feedback comparator. This improved load regulation is at the expense of slightly increasing the amount of noise on the output at higher loads. Values between 100pF and 1nF are recommended to prevent instability.

Power Good (PG)

The evaluation board has a test point provided for monitoring the power good feature. This is an open drain connection with an on-board pull-up resistor of 10k to the output voltage. Power good is asserted high approximately 70μs after the output voltage passes 90% of the nominal set voltage.

HyperLight Load Mode

MIC23158 uses a minimum on and off time proprietary control loop (patented by Micrel). When the output voltage falls below the regulation threshold, the error comparator begins a switching cycle that turns the PMOS on and keeps it on for the duration of the minimum-on-time. This increases the output voltage. If the output voltage is over the regulation threshold, then the error comparator turns the PMOS off for a minimum-off-time until the output drops below the threshold. The NMOS acts as an ideal rectifier that conducts when the PMOS is off. Using a NMOS switch instead of a diode allows for lower voltage drop across the switching device when it is on. The synchronous switching combination between the PMOS and the NMOS allows the control loop to work in discontinuous mode for light load operations. In discontinuous mode, the MIC23158 works in pulse frequency modulation (PFM) to regulate the output. As the output current increases, the off-time decreases, thus providing more energy to the output. This switching scheme improves the efficiency of MIC23158 during light load currents by only switching when it is needed.

As the load current increases, the MIC23158 goes into continuous conduction mode (CCM) and switches at a frequency centered at 3MHz. The equation to calculate the load when the MIC23158 goes into continuous conduction mode may be approximated by Equation 2:

$$I_{\text{LOAD}} > \left(\frac{(V_{\text{IN}} - V_{\text{OUT}}) \times D}{2L \times f} \right) \quad \text{Eq. 2}$$

As shown in Equation 2, the load at which MIC23158 transitions from HyperLight Load mode to PWM mode is a function of the input voltage (V_{IN}), output voltage (V_{OUT}), duty cycle (D), inductance (L) and frequency (f). Refer to the “Switching Frequency vs. Output Current” graph in the [Evaluation Board Performance](#) section to see an example of how when the output current increases, the switching frequency also increases until the MIC23158 goes from HyperLight Load mode to PWM mode at approximately 180mA. The MIC23158 will switch at a relatively constant frequency around 3MHz once the output current is over 180mA.

Evaluation Board Performance

Efficiency ($V_{OUT} = 3.3V$) vs. Output Current

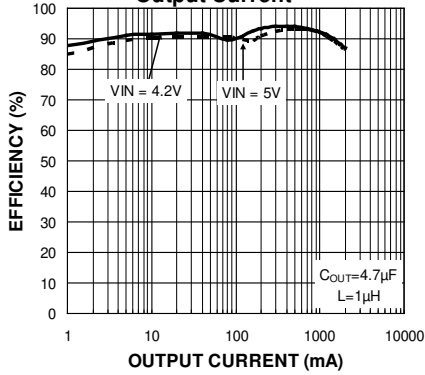

Efficiency ($V_{OUT} = 2.5V$) vs. Output Current

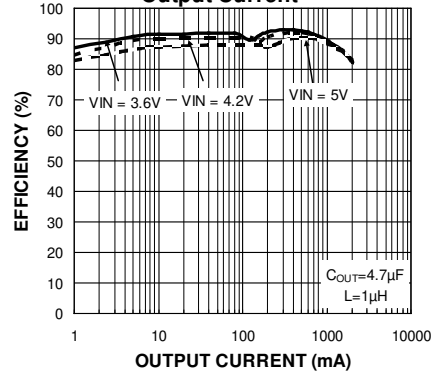

Efficiency ($V_{OUT} = 1.8V$) vs. Output Current

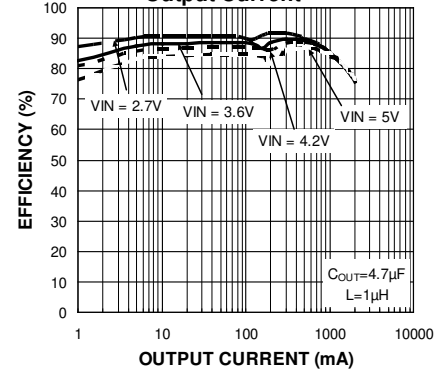

Efficiency ($V_{OUT} = 1.5V$) vs. Output Current

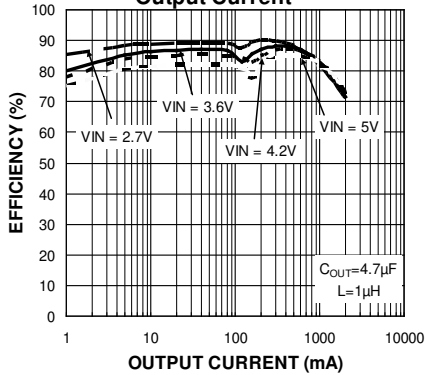

V_{OUT} Rise Time vs. C_{SS}

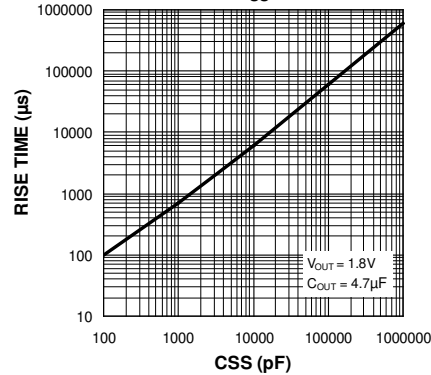

Switching Frequency vs. Output Current

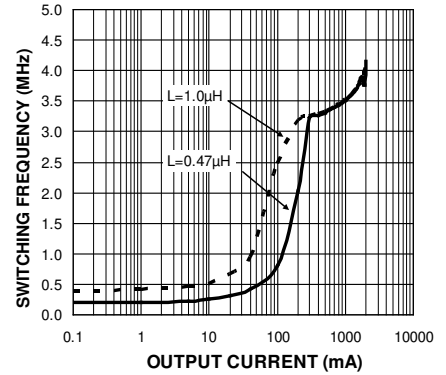

Evaluation Board Schematic (Adjustable Output)

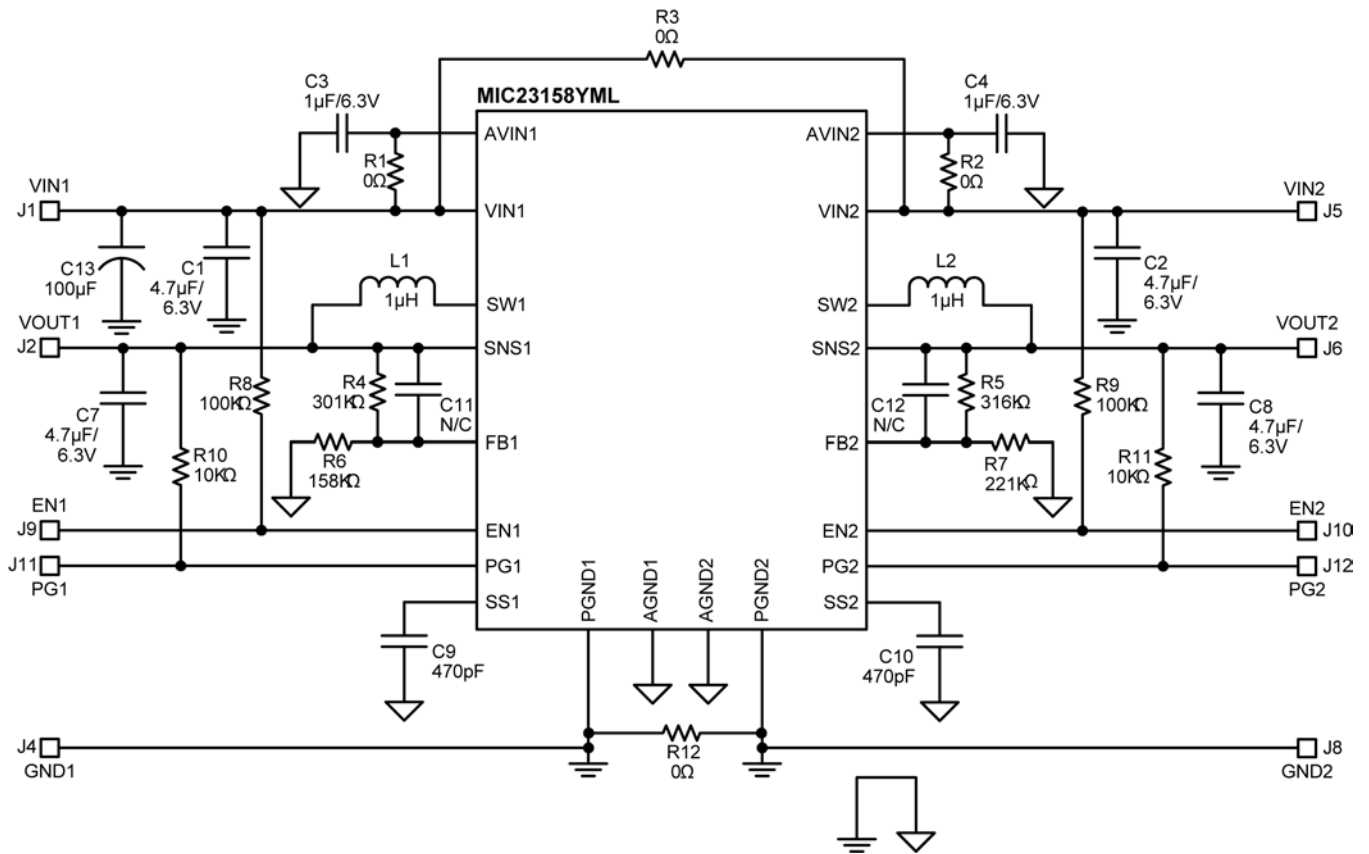

Bill of Materials

Item	Part Name	Manufacturer	Description	Qty.
C1, C2, C7, C8	06036D475KAT2A	AVX ⁽¹⁾	4.7 μ F, 6.3V, X5R, 0603	4
	GRM188R60J475KE19D	Murata ⁽²⁾		
	C1608X5R0J475K	TDK ⁽³⁾		
C3, C4	06036D105KAT2A	AVX	1 μ F, 0603, 6.3V	2
	GRM188R60J105KA01D	Murata		
	C1608X5R0J105K	TDK		
C9, C10	06035A471JAT2A	AVX	470pF, 50V, 0603	2
	GRM1885C1H471JA01D	Murata		
	C1608C0G1H471J	TDK		
C13	EKY-500ELL101MHB5D	United Chemi-con ⁽⁴⁾	Cap Alum, 100 μ F, 50V, 20%, Radial	1
L1, L2	CDRH4D28CLDNP-1R0P	Sumida ⁽⁵⁾	1 μ H, 3.0A, 14m Ω , L5.1mm x W5.1mm x H3.0mm	2
	LQH44PN1R0NJ0	Murata	1 μ H, 2.0A, 48m Ω , L4.0mm x W4.0mm x H1.1mm	
R1, R2, R3, R12	CRCW06030000Z0EA	Vishay/Dale ⁽⁶⁾	0 Ω , 1/10W, 0603	4
R4	CRCW06033013FKEA	Vishay/Dale	301K Ω , 1%, 1/10W, 0603	1
R5	CRCW06033163FKEA	Vishay/Dale	316K Ω , 1%, 1/10W, 0603	1
R6	CRCW06031583FKEA	Vishay/Dale	158K Ω , 1%, 1/10W, 0603	1
R7	CRCW06032213FKEA	Vishay/Dale	221K Ω , 1%, 1/10W, 0603	1
R8, R9	CRCW06031003FKEA	Vishay/Dale	100K Ω , 1%, 1/10W, 0603	2
R10, R11	CRCW06031002FKEA	Vishay/Dale	10K Ω , 1%, 1/10W, 0603	2
U1	MIC23158YML	Micrel, Inc.⁽⁷⁾	3MHz, PWM, Dual 2A Buck Regulator with HyperLight Load and Power Good	1

Notes:

1. AVX: www.avx.com.
2. Murata: www.murata.com.
3. TDK: www.tdk.com.
4. United Chemi-con: www.chemi-con.com.
5. Sumida: www.sumida.com.
6. Vishay: www.vishay.com.
7. Micrel, Inc.: www.micrel.com.

PCB Layout Recommendations

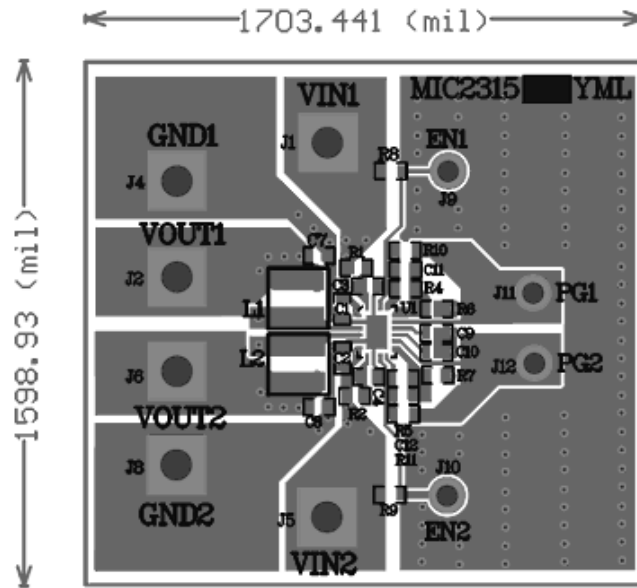

Top Layer

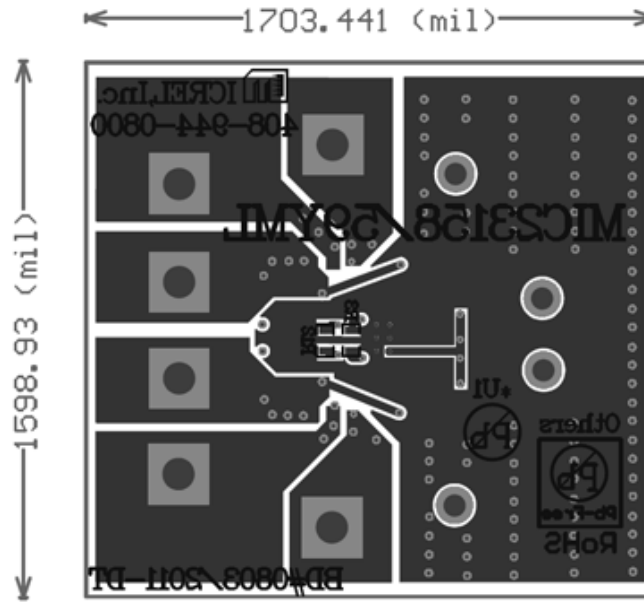

Bottom Layer

MICREL, INC. 2180 FORTUNE DRIVE SAN JOSE, CA 95131 USA
TEL +1 (408) 944-0800 FAX +1 (408) 474-1000 WEB <http://www.micrel.com>

Micrel makes no representations or warranties with respect to the accuracy or completeness of the information furnished in this data sheet. This information is not intended as a warranty and Micrel does not assume responsibility for its use. Micrel reserves the right to change circuitry, specifications and descriptions at any time without notice. No license, whether express, implied, arising by estoppel or otherwise, to any intellectual property rights is granted by this document. Except as provided in Micrel's terms and conditions of sale for such products, Micrel assumes no liability whatsoever, and Micrel disclaims any express or implied warranty relating to the sale and/or use of Micrel products including liability or warranties relating to fitness for a particular purpose, merchantability, or infringement of any patent, copyright or other intellectual property right.

Micrel Products are not designed or authorized for use as components in life support appliances, devices or systems where malfunction of a product can reasonably be expected to result in personal injury. Life support devices or systems are devices or systems that (a) are intended for surgical implant into the body or (b) support or sustain life, and whose failure to perform can be reasonably expected to result in a significant injury to the user. A Purchaser's use or sale of Micrel Products for use in life support appliances, devices or systems is a Purchaser's own risk and Purchaser agrees to fully indemnify Micrel for any damages resulting from such use or sale.

© 2013 Micrel, Incorporated.

Revision History

Date	Change Description/Edits by:	Rev.
02/04/13	Initial draft version reflowed into 2013 template – by S. Thompson	1.0