



Chipsmall Limited consists of a professional team with an average of over 10 year of expertise in the distribution of electronic components. Based in Hongkong, we have already established firm and mutual-benefit business relationships with customers from,Europe,America and south Asia,supplying obsolete and hard-to-find components to meet their specific needs.

With the principle of “Quality Parts,Customers Priority,Honest Operation,and Considerate Service”,our business mainly focus on the distribution of electronic components. Line cards we deal with include Microchip,ALPS,ROHM,Xilinx,Pulse,ON,Everlight and Freescale. Main products comprise IC,Modules,Potentiometer,IC Socket,Relay,Connector.Our parts cover such applications as commercial,industrial, and automotives areas.

We are looking forward to setting up business relationship with you and hope to provide you with the best service and solution. Let us make a better world for our industry!



Contact us

Tel: +86-755-8981 8866 Fax: +86-755-8427 6832

Email & Skype: info@chipsmall.com Web: www.chipsmall.com

Address: A1208, Overseas Decoration Building, #122 Zhenhua RD., Futian, Shenzhen, China



**PART NUMBER:** EPA090050-P5-SZ**DESCRIPTION:** linear adapter**SPECIFICATIONS**

output voltage	9 V ac at 500 mA	
rated input voltage	120 V ac	
primary rated voltage	120 V ac 60 Hz 8 W	
primary exciting current	30 mA rms max.	
secondary rated voltage & current	no load voltage (max.)	11 V
	full load voltage (500 mA)	9 V \pm 5%
temperature rise of primary winding (full load)	70°C max. using resistance method	
insulation resistance	\geq 100 M Ohm at 500 Vdc	
HI-POT test	primary to secondary	1240 V ac at 2 mA for 1 minute
	primary to secondary	1600 V ac at 2 mA for 1 second
	primary winding to secondary winding	1600 V ac at 2 mA for 1 second
	primary winding to core	1600 V ac at 2 mA for 1 second
	secondary winding to core	750 V ac at 2 mA for 1 second
safety standard	UL/cUL	
RoHS compliant	yes	
weight	218 g	
test conditions	ambient temp	40 \pm 2°C
	humidity	90~95% 96 hours at Full Load
	rated voltage	8 hours at full load
adapter color	case	black
	cord	black

PART NUMBER: EPA090050-P5-SZ

DESCRIPTION: linear adapter

LABEL

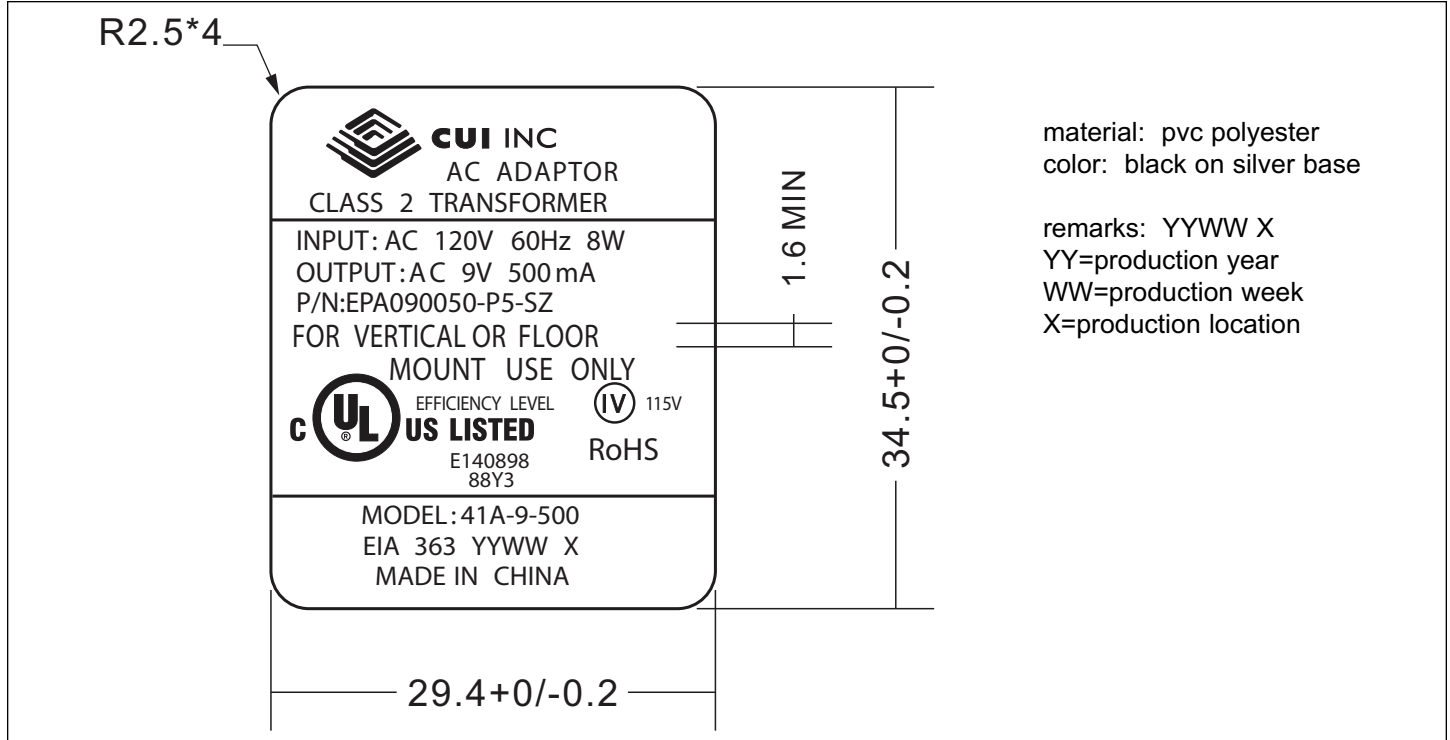

PART NUMBER: EPA090050-P5-SZ

DESCRIPTION: linear adapter

CIRCUIT DIAGRAM

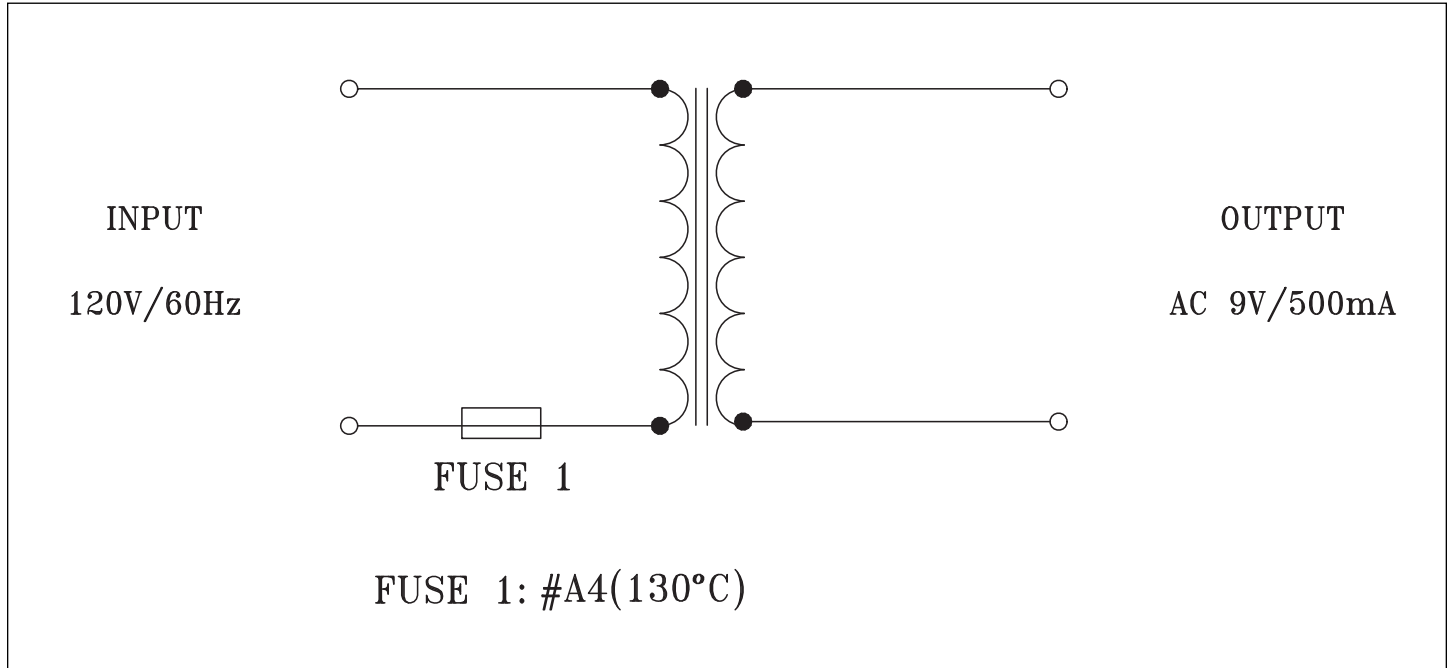

TEST CIRCUIT

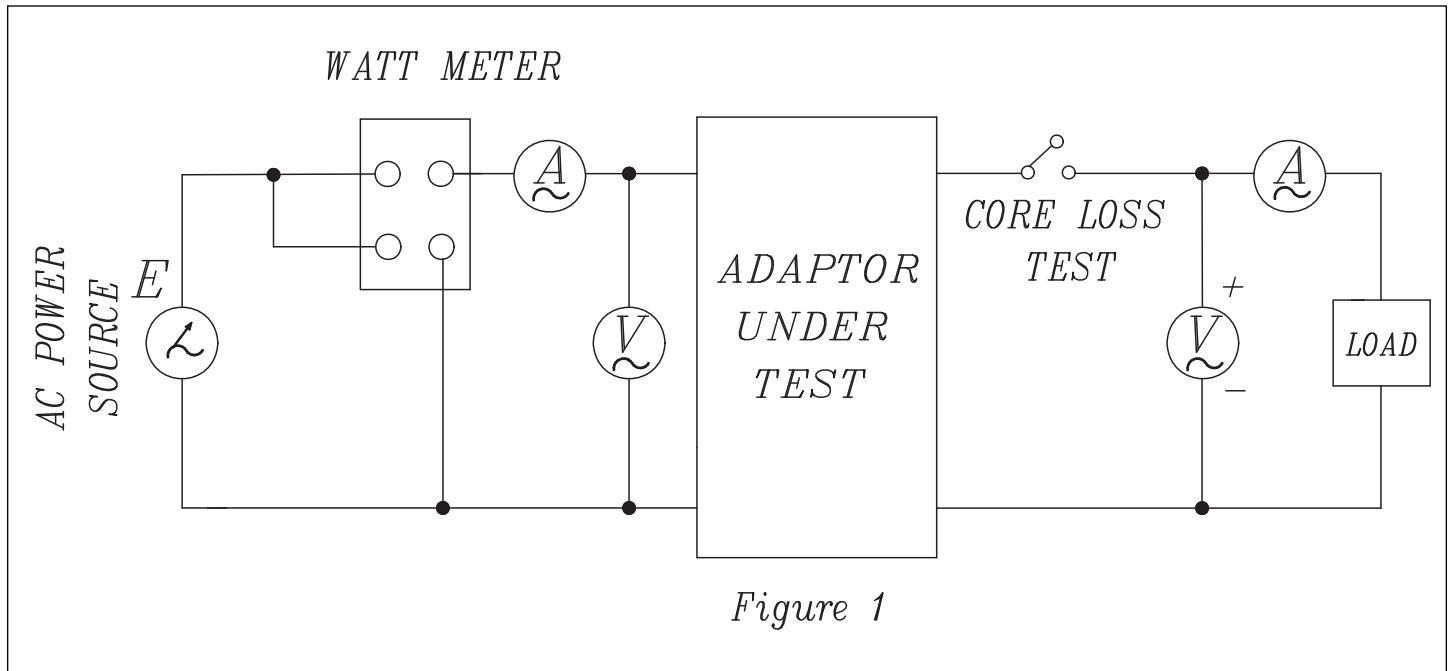

PART NUMBER: EPA090050-P5-SZ

DESCRIPTION: linear adapter

MECHANICAL DRAWING

weight	218 g
tolerance	±1mm

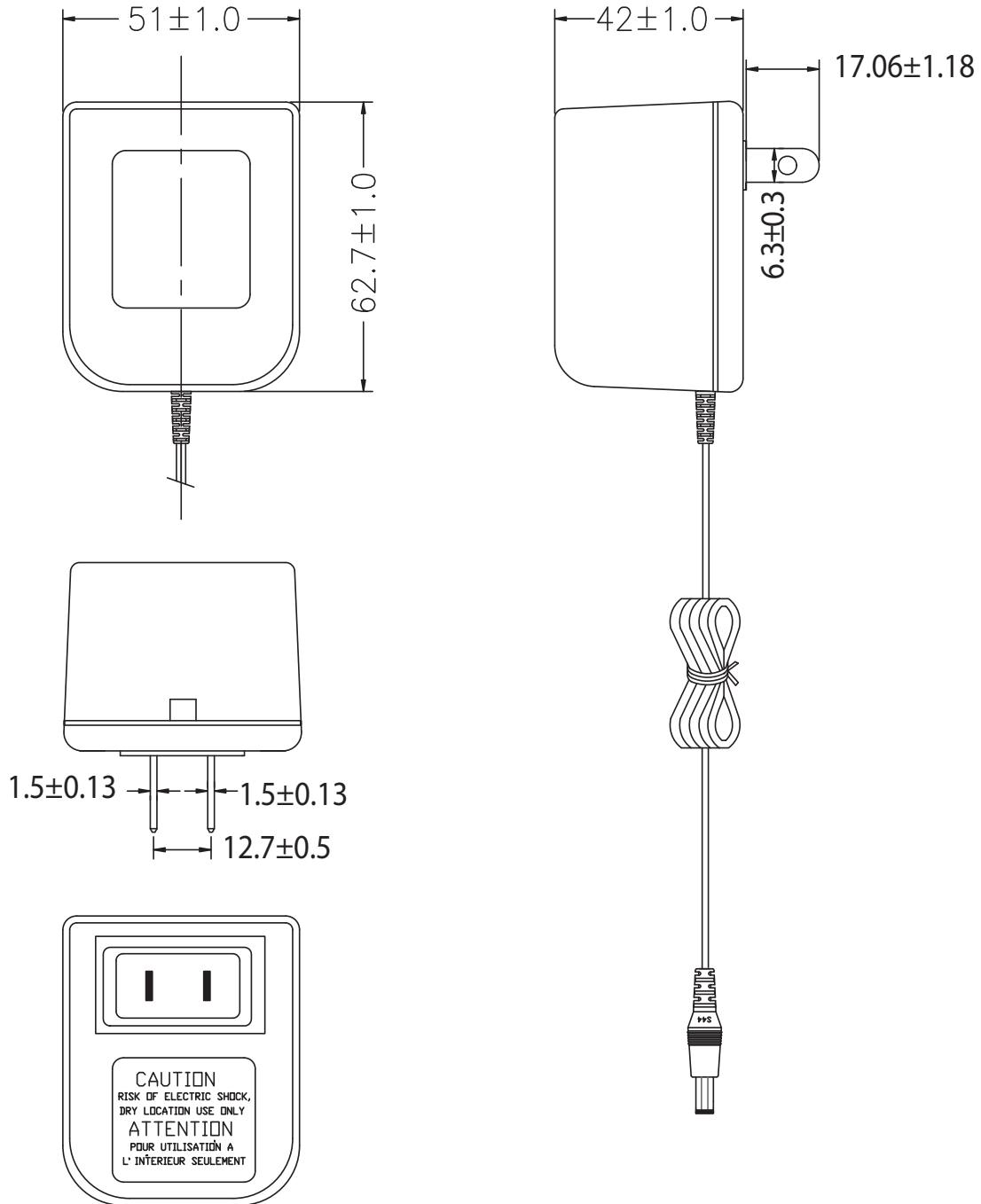

PART NUMBER: EPA090050-P5-SZ

DESCRIPTION: linear adapter

DC CORD

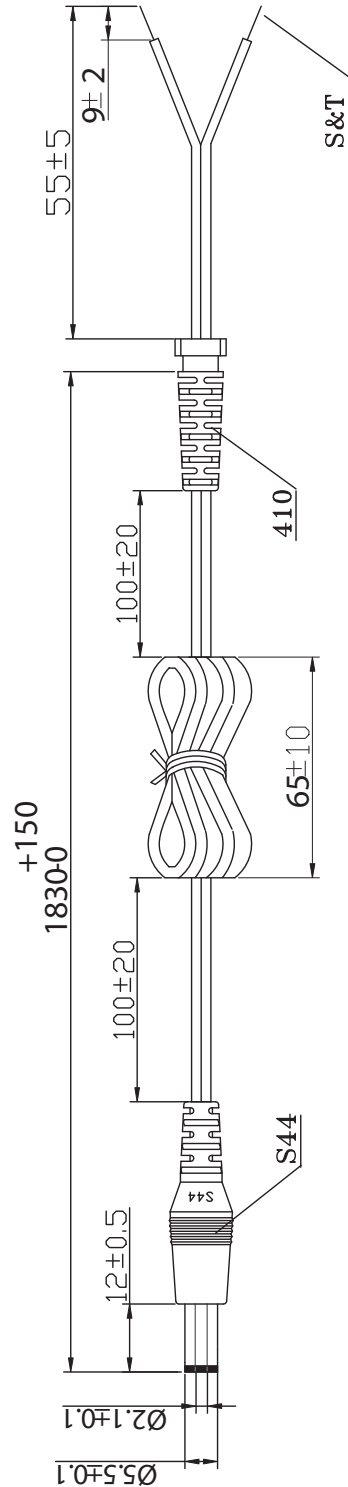

#24AWG X2C UL2468 HAVE ON WORD WIRE IN OUTER, NO WORD WIRE IN INNER

WIRE OD: Ø 1.5X3.0

VIBRATION TEST	Parameter request
	a. ±60° b. WEIGHT 200g c. 40 ROUND/MINUTE d. OVER 1000 COUNT MIN

PART NUMBER: EPA090050-P5-SZ

DESCRIPTION: linear adapter

INDIVIDUAL PACKAGING

tolerance: ± 1

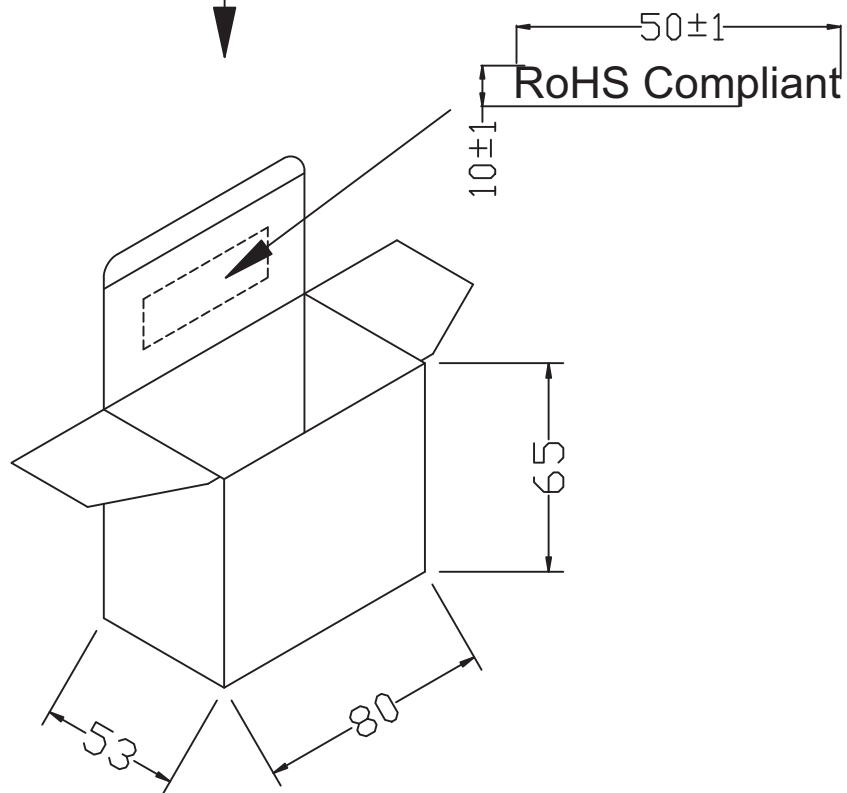
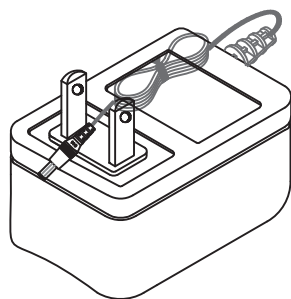

PART NUMBER: EPA090050-P5-SZ

DESCRIPTION: linear adapter

PACKAGING

tolerance: +7/-0

OUTSIDE CARTON:A=B(6mm)
INSIDE CARTON:B3B(3mm)
CARTON SIZE: 350X345X190mm
Q'TY: 60pcs(20x3x1)

