



Chipsmall Limited consists of a professional team with an average of over 10 year of expertise in the distribution of electronic components. Based in Hongkong, we have already established firm and mutual-benefit business relationships with customers from,Europe,America and south Asia,supplying obsolete and hard-to-find components to meet their specific needs.

With the principle of “Quality Parts,Customers Priority,Honest Operation,and Considerate Service”,our business mainly focus on the distribution of electronic components. Line cards we deal with include Microchip,ALPS,ROHM,Xilinx,Pulse,ON,Everlight and Freescale. Main products comprise IC,Modules,Potentiometer,IC Socket,Relay,Connector.Our parts cover such applications as commercial,industrial, and automotives areas.

We are looking forward to setting up business relationship with you and hope to provide you with the best service and solution. Let us make a better world for our industry!



## Contact us

Tel: +86-755-8981 8866 Fax: +86-755-8427 6832

Email & Skype: info@chipsmall.com Web: www.chipsmall.com

Address: A1208, Overseas Decoration Building, #122 Zhenhua RD., Futian, Shenzhen, China





# MIC24420/MIC24421

## 2.5A Dual Output PWM Synchronous Buck Regulator IC

### General Description

The MIC24420/MIC24421 are synchronous PWM dual output step down converters with internal 2.5A high-side switches. The MIC24420/MIC24421 has an integrated low-side gate driver for synchronous step-down conversion by connecting an external N-channel MOSFET to achieve high efficiencies in low duty-cycle applications.

The MIC24420 switching frequency is 1MHz and the MIC24421 switching frequency is 500kHz. A patented control scheme allows the use of a wide range of output capacitance from small ceramic capacitors to large electrolytic types with only one compensation component. A 2% output voltage tolerance over the temperature range allows the maximum level of system performance. The MIC24420/MIC24421 power good signal allows full control for sequencing the output voltages with minimum external components.

An adjustable current limit allows the use of smaller inductors in lower current applications.

The MIC24420/MIC24421 is available in a ePad 24-pin 4mm x 4mm MLF<sup>®</sup> package, and has an operating junction temperature range of -40°C to +125°C.

### Features

- 4.5V to 15V input voltage range
- Adjustable output voltages down to 0.7V
- 2.5A per channel
- 180° out of phase operation
- Pre-biased output startup capability
- Low-side driver for synchronous operation
- 2% output voltage accuracy (over temperature)
- 500kHz (MIC24421) and 1MHz (MIC24420) switching frequency
- Output voltage sequencing
- Programmable max current limit
- Power good output
- Ramp Control™ provides soft-start
- Low-side current sensing allows very low duty-cycle
- Works with ceramic output capacitors
- 24-pin 4mm x 4mm MLF<sup>®</sup> package
- Junction temperature range of -40°C to +125°C

### Applications

- Multi-output power supplies with sequencing
- DSP, FPGA, CPU and ASIC power supplies
- Telecom and networking equipment, servers

### Typical Application

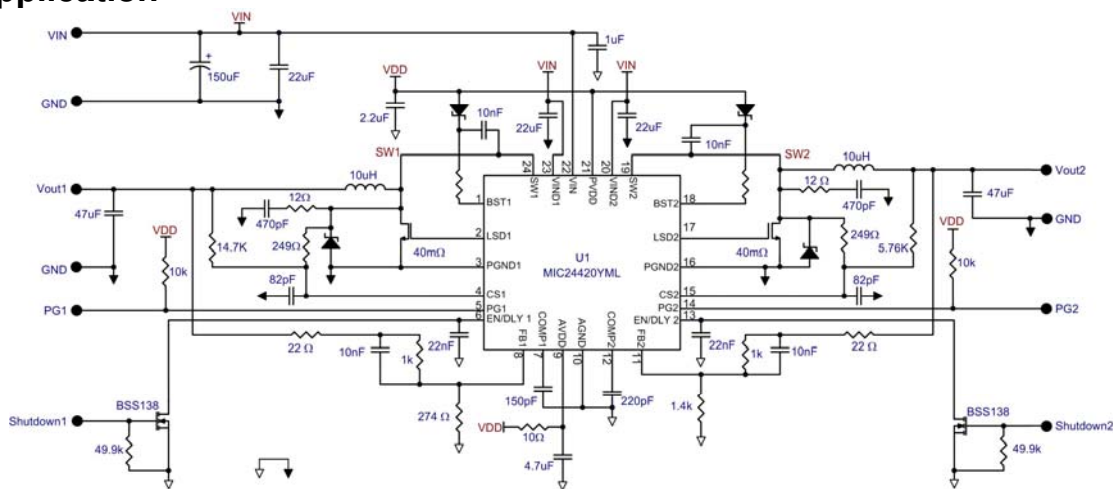

MIC24420 Dual Output Buck Converter

Ramp Control is a trademark of Micrel, Inc.  
MLF and MicroLeadFrame are registered trademarks of Amkor Technology, Inc.

Micrel Inc. • 2180 Fortune Drive • San Jose, CA 95131 • USA • tel +1 (408) 944-0800 • fax + 1 (408) 474-1000 • <http://www.micrel.com>

## Ordering Information

Part Number	Voltage	Switching Frequency	Temperature Range	Package	Lead Finish
MIC24420YML	Adj	1MHz	-40°C to +125°C	24-Pin 4mm x 4mm MLF <sup>®</sup>	Pb-Free
MIC24421YML	Adj	500kHz	-40°C to +125°C	24-Pin 4mm x 4mm MLF <sup>®</sup>	Pb-Free

### Notes:

1. MLF<sup>®</sup> is GREEN RoHS compliant package. Lead finish is NiPdAu. Mold compound is Halogen Free.
2. MLF<sup>®</sup> ● = Pin 1 identifier

## Pin Configuration

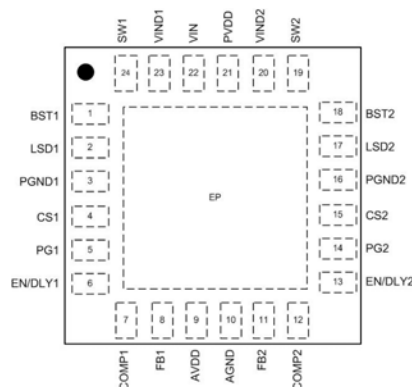

24-Pin 4mm x 4mm MLF (ML)

## Pin Description

Pin Number	Pin Name	Pin Description
1	BST1	Boost 1 (Input): Provides voltage for high-side internal MOSFET for channel 1. Connect a 0.01 $\mu$ F capacitor from SW1 to BST1 pin and a diode to PVDD.
2	LSD1	Low-side Drive 1 (Output): External low-side N-Channel MOSFET driver. Use 4.5V rated MOSFETs.
3	PGND1	Power Ground 1 (Input).
4	CS1	Current Sense 1 (Input): Place a resistor from SW1 to this pin to program the current limit point from 0.5A to 2.7A.
5	PG1	Power Good 1 (Output): Open drain. Device is in the OFF state. i.e. high when output is within 90% of regulation.
6	EN/DLY1	Enable/Delay 1 (Input): This pin can be used to disable $V_{OUT1}$ . When used to disable $V_{OUT1}$ , this pin must be pulled down to ground in less than 1 $\mu$ s for proper operation. It is also used for soft-start of the output. Soft start capacitor range is 4.7nF to 22nF. See Functional Description section for additional information.
7	COMP1	Compensation 1 (Input): Pin for external compensation, Channel 1.
8	FB1	Feedback 1 (Input): Input to Ch1 error amplifier. Regulates to 0.7V.
9	AVDD	5V Internal Linear Regulator (Output): Connect to an external 4.7 $\mu$ F bypass capacitor. When $V_{IN}$ is <6V, this regulator operates in drop-out mode. Connect AVDD to VIN when $V_{IN}$ <6V.
10	AGND	Analog Ground (Input): Control section ground. Connect to PGND.
11	FB2	Feedback 2 (Input): Input to Channel 2 error amplifier. Regulates to 0.7V.
12	COMP2	Compensation 2 (Input): Pin for external compensation, Channel 2.

**Pin Description (Continued)**

Pin Number	Pin Name	Pin Description
13	EN/DLY2	Enable/Delay 2 (Input): This pin can be used to disable $V_{OUT2}$ . When used to disable $V_{OUT2}$ , this pin must be pulled down to ground in less than $1\mu\text{s}$ for proper operation. It is also used for soft-start of the output. Soft start capacitor range is 4.7nF to 22nF. See Functional Description section for additional information.
14	PG2	Power Good 2 (Output) Open drain. Device is in the OFF state. i.e. high when output is within 90% of regulation
15	CS2	Current Sense 2 (Input) Place a resistor from SW2 to this pin to program the current limit point from 0.5A to 2.7A
16	PGND2	Power Ground 2 (Input)
17	LSD2	Low-side Drive 2 (Output): External low-side N-Channel MOSFET driver. Use 4.5V rated MOSFETs.
18	BST2	Boost 2 (Input): Provides voltage for high-side internal MOSFET for Channel 2. Connect a $0.01\mu\text{F}$ capacitor from SW2 to BST2 pin and a diode to PVDD.
19	SW2	Switch Node 2 (Output): Source of internal high-side power MOSFET.
20	VIND2	Supply voltage (Input): For the drain of internal high-side power MOSFET 4.5V to 13.2V.
21	PVDD	5V VDD input (input): Power connection to the internal MOSFET drivers. Connect to AVDD through an RC filter
22	VIN	Supply voltage (Input): For the internal 5V linear regulator. 4.5V to 13.2V.
23	VIND1	Supply voltage (Input): For the drain of internal high-side power MOSFET 4.5V to 13.2V.
24	SW1	Switch Node 1 (Output): Source of internal high-side power MOSFET.
EP	ePad	Exposed thermal pad for package only. Connect to ground. Must make a full connection to the ground plane to maximize thermal performance of the package.

**Absolute Maximum Ratings<sup>(1)</sup>**

$V_{IN}$ to PGND	-0.3V to 16V
$V_{IND1}$ , $V_{IND2}$ to PGND	-0.3V to 16V
$V_{DD}$ to PGND	-0.3V to 6V
$V_{SW1}$ , $V_{SW2}$ to PGND	-0.7V to ( $V_{IN} + 0.3V$ )
$V_{CS1}$ , $V_{CS2}$ to PGND	-0.7V to ( $V_{IN} + 0.3V$ )
$V_{BST1}$ to $V_{SW1}$ , $V_{BST2}$ to $V_{SW2}$	-0.3V to 6V
$V_{BST1}$ , $V_{BST2}$ to PGND	-0.3V to $V_{SW}+6V$
$V_{EN/DLY}$ , $V_{COMP}$ , $V_{FB}$ , $V_{PG}$ to PGND	-0.7V to ( $V_{AVDD} + 0.3V$ )
PGND1, PGND2 to AGND	-0.3V to +0.3V
Junction Temperature	150°C
Storage Temperature	-65°C to +150°C
Lead Temperature (soldering, 10 sec.)	260°C
ESD Rating <sup>(3)</sup>	ESD Sensitive

**Operating Ratings<sup>(2)</sup>**

Supply Voltage ( $V_{IN}$ )	+4.5V to +15V
Output Voltage Range ( $V_{OUT}$ )	0.7V to $0.7 \cdot V_{IN}$
Maximum Output Current ( $I_{OUT}$ )	2.5A
Junction Temperature ( $T_J$ )	-40°C to +125°C
Junction Thermal Resistance	
4mmx4mm MLF-24L ( $\theta_{JC}$ )	14°C/W
4mmx4mm MLF-24L ( $\theta_{JA}$ )	35°C/W

**Electrical Characteristics<sup>(4)</sup>**

$V_{IN} = 12V$ ;  $V_{EN}=5V$ ;  $V_{OUT}=1.8V$ ;  $I_{LOAD}=10mA$ ;  $T_A = 25^\circ C$ , **bold** values indicate  $-40^\circ C \leq T_J \leq +125^\circ C$ , unless noted.

Parameter	Condition	Min	Typ	Max	Units
<b>Power Input Supply</b>					
Input Voltage Range ( $V_{IN}$ )		4.5		15	V
Quiescent Supply Current	$V_{FB} = 0.8V$ , $I_{OUT} = 0A$ ; Both outputs not switching		2.6	<b>7</b>	mA
Shutdown Current	$V_{EN1} = V_{EN2} = 0V$		25	<b>50</b>	$\mu A$
$V_{IN}$ UVLO Turn-On Threshold	$V_{IN}$ Rising, $V_{DD} = V_{IN}$	<b>3.6</b>	4.1	<b>4.45</b>	V
$V_{IN}$ UVLO Hysteresis	$V_{DD} = V_{IN}$		400		mV
<b>VDD Supply</b>					
Internal Bias Voltages $A_{VDD}$	$V_{FB} = 0.8V$ , $I_{AVDD} = 50mA$	4.7	5.1	5.45	V
<b>Reference (Each Channel)</b>					
Feedback Reference Voltage		<b>686</b>	700	<b>714</b>	mV
FB Bias Current	$V_{FB} = 0.7V$		5		nA
FB Line Regulation	$V_{IN} = 6V$ to $15V$ , $I_{OUT} = 10mA$		0.005		%/V
Output Voltage Line Regulation	$V_{IN} = 6V$ to $15V$ , $V_{OUT} = 1.8V$ , $I_{OUT} = 1A$ ; each channel		0.005		%/V
Output Voltage Load Regulation	$V_{OUT} = 1.8V$ , $I_{OUT} = 0A$ to $2A$ ; each channel		0.15		%
Output Voltage Total Regulation	$V_{IN} = 6V$ to $15V$ , $I_{OUT} = 0.25A$ to $2A$ , $V_{OUT} = 1.8V$ ; each channel		0.1		%
<b>External Current Sense, Adjustable</b>					
Current Limit Trip Point Current	Sourcing current	175	200	225	$\mu A$
Current Limit Temperature Coefficient	$T_J = -40^\circ C$ to $125^\circ C$		750		ppm/ $^\circ C$
Current Limit Comparator Offset		<b>-20</b>	0	<b>10</b>	mV

**Electrical Characteristics<sup>(4)</sup> (Continued)**

Parameter	Condition	Min	Typ	Max	Units
<b>Oscillator / PWM</b>					
Switching Frequency	MIC24420	<b>0.8</b>	1	<b>1.2</b>	MHz
	MIC24421	<b>0.4</b>	0.5	<b>0.6</b>	
Maximum Duty Cycle	MIC24420	<b>70</b>	76		%
	MIC24421	<b>85</b>	90		
Minimum On-Time	$I_{LOAD} > 200\text{mA}$ <sup>(5)</sup>		60		ns
<b>High-side Internal MOSFET</b>					
On Resistance $R_{DS(ON)}$	$I_{FET} = 1\text{A}$ , $V_{FB}=0.8\text{V}$		150		m $\Omega$
<b>Low-side MOSFET Driver</b>					
DH On-Resistance	Pull Up, $I_{SOURCE} = 10\text{mA}$		4		$\Omega$
	Pull Down; $I_{SINK} = 10\text{mA}$		2.5		$\Omega$
DH Transition Time	Rising Into 1000pF		12		ns
	Falling Into 1000pF		9		ns
Driver Non-overlap Dead Time	(Adaptive)		25		ns
<b>EN/DLY and Soft-start Control</b>					
EN/DLY Pull-up Current	$V_{EN/DLY1} = V_{EN/DLY2} = 0\text{V}$	<b>5.5</b>	7	<b>8.5</b>	$\mu\text{A}$
$A_{VDD}$ Threshold	$A_{VDD}$ turns on	<b>0.4</b>	0.58	<b>0.65</b>	V
Soft-start Begins Threshold	Channel soft-start begins	<b>1.1</b>	1.35	<b>1.8</b>	V
Soft-start Ends Threshold	Channel soft-start ends	<b>2</b>	2.4	<b>2.8</b>	V
<b>Power Good</b>					
PG Threshold Voltage	$V_{OUT}$ Rising (% of $V_{OUT}$ nominal)	<b>85</b>	90	<b>95</b>	%Nom
PG Output Low Voltage	$V_{FB} = 0\text{V}$ , $I_{PG} = 1\text{mA}$		0.08	<b>0.3</b>	V
PG Leakage Current	$V_{FB} = 800\text{mV}$ , $V_{PG} = 5.5\text{V}$		5		nA
<b>Thermal Protection</b>					
Over-temperature Shutdown	$T_J$ Rising		165		$^{\circ}\text{C}$
Over-temperature Shutdown Hysteresis			22		$^{\circ}\text{C}$

**Notes:**

- Exceeding the absolute maximum rating may damage the device.
- The device is not guaranteed to function outside its operating rating.
- Devices are ESD sensitive. Handling precautions recommended. Human body model, 1.5k $\Omega$  in series with 100pF.
- Specification for packaged product only.
- Minimum on-time before automatic cycle skipping begins. See applications section.

# Typical Characteristics

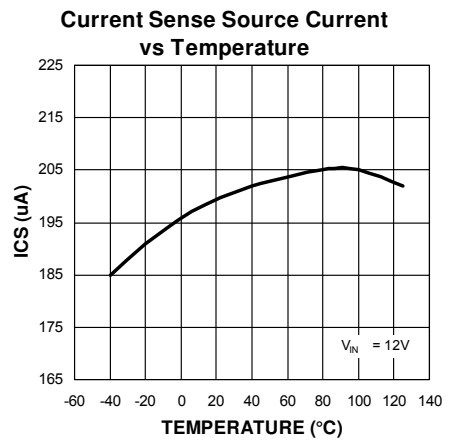
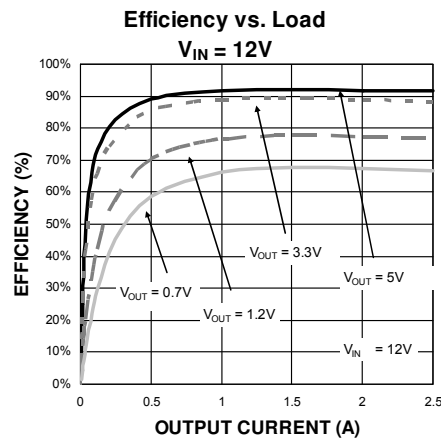
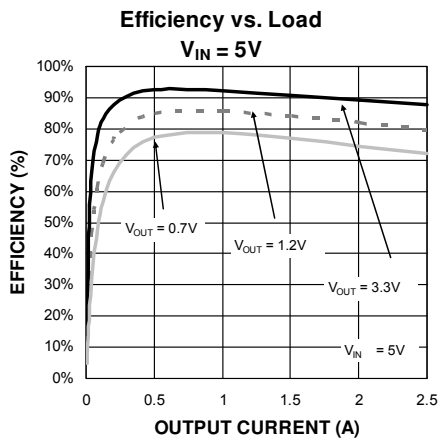
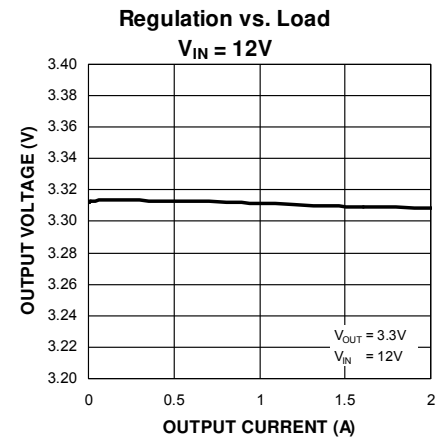
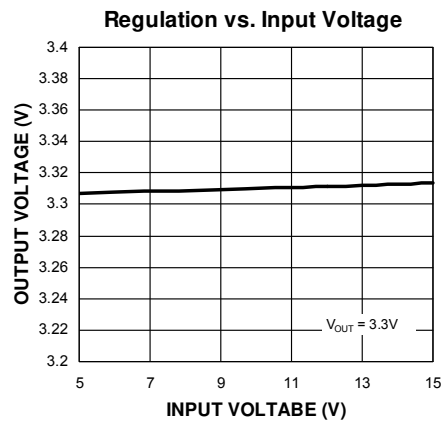
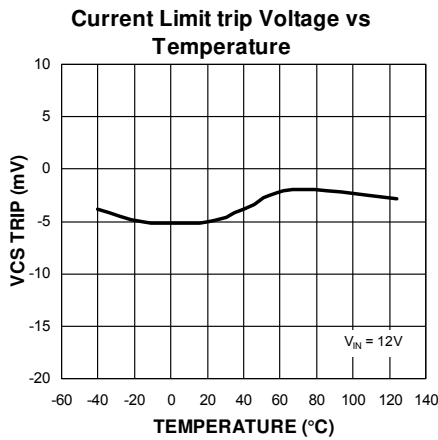
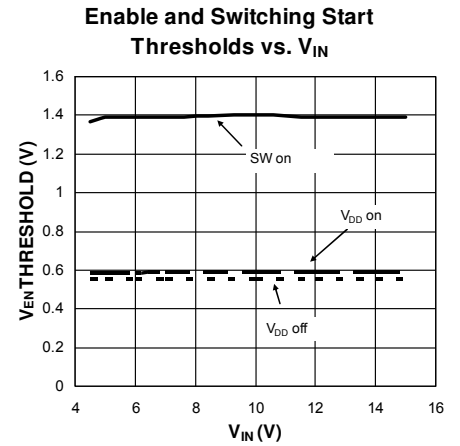
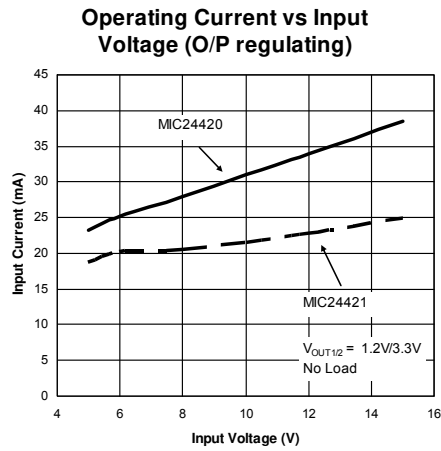
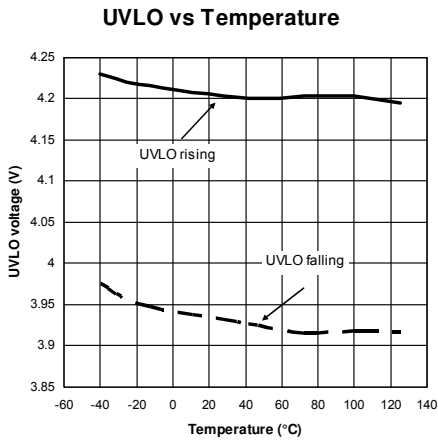

## Functional Characteristics

**MIC24420 Switching Waveform**

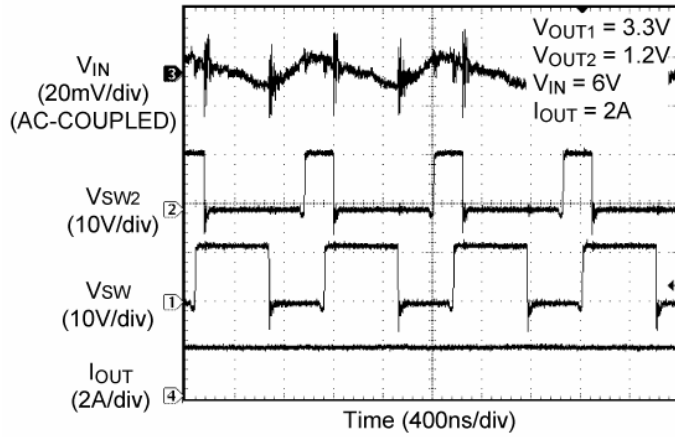

**MIC24421 Switching Waveform**

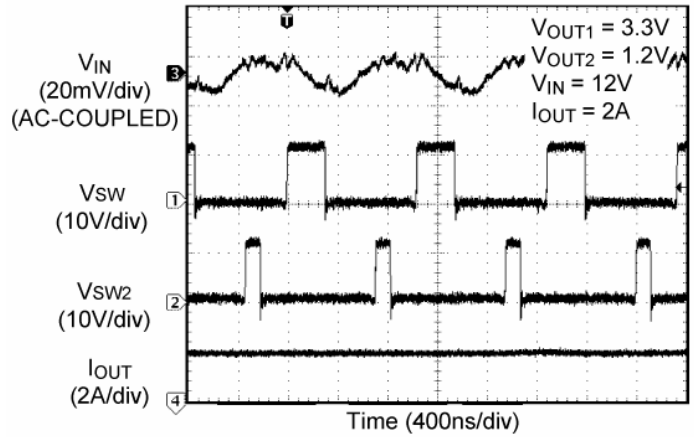

**Output Current Transient Response CH1**

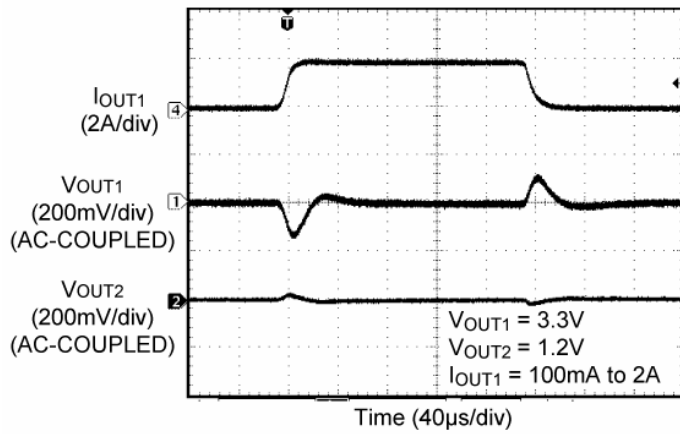

**Output Current Transient Response CH2**

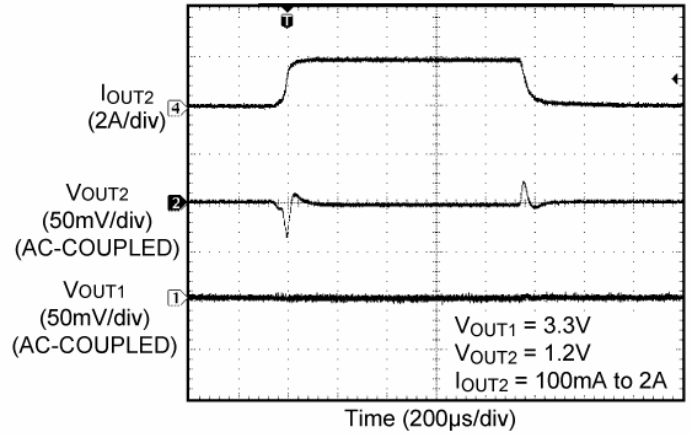



## Functional Characteristics (Continued)

**Startup Waveforms**

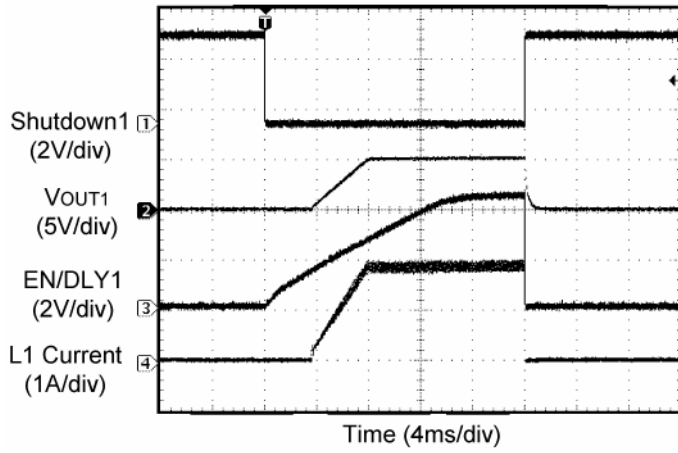

**Sequenced Startup (PG1 tied to EN/DLY2)**

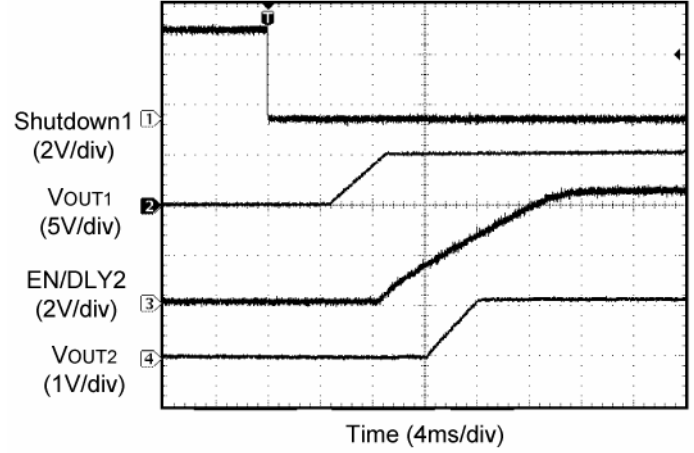

**Startup Into Overload (1Ω on 5V output)**

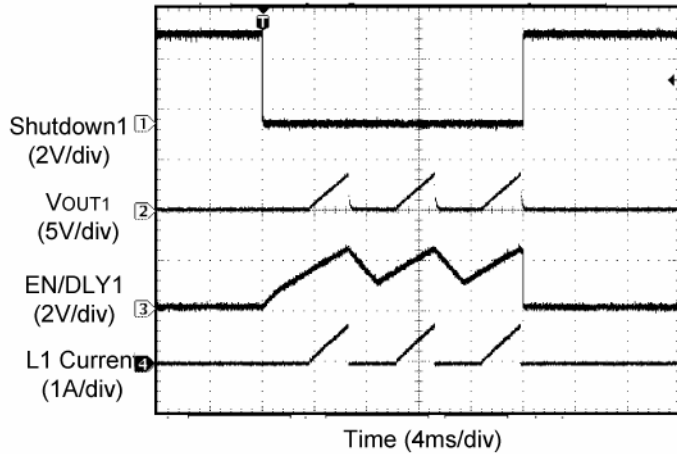

**Pre-bias Startup (VOUT1=3.3V)**

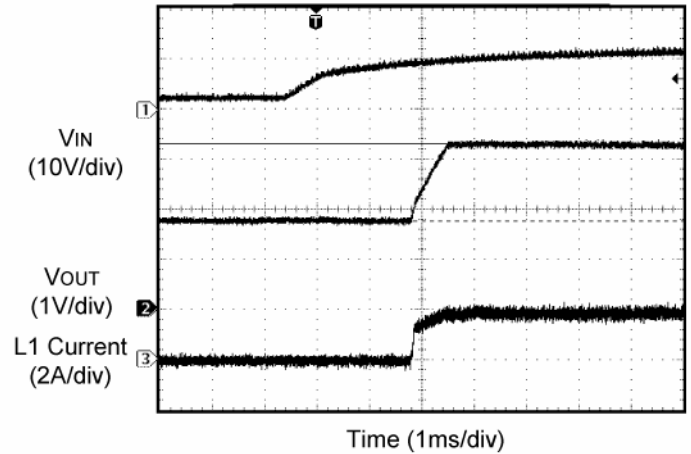

## Functional Characteristics (Continued)

**Response to Short Circuit**

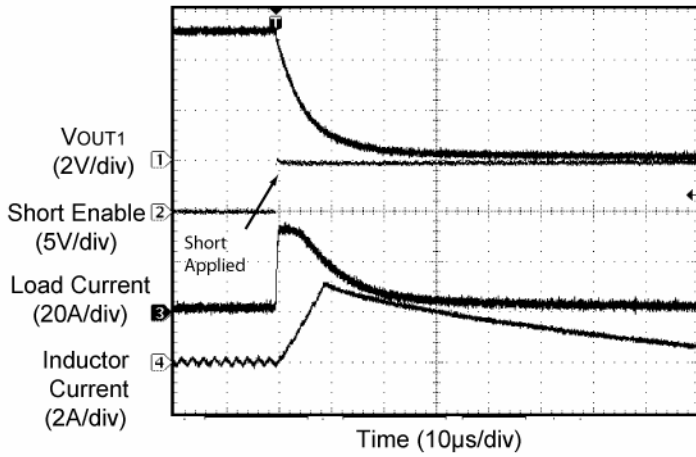

**Hiccup Mode Current Limit Action**

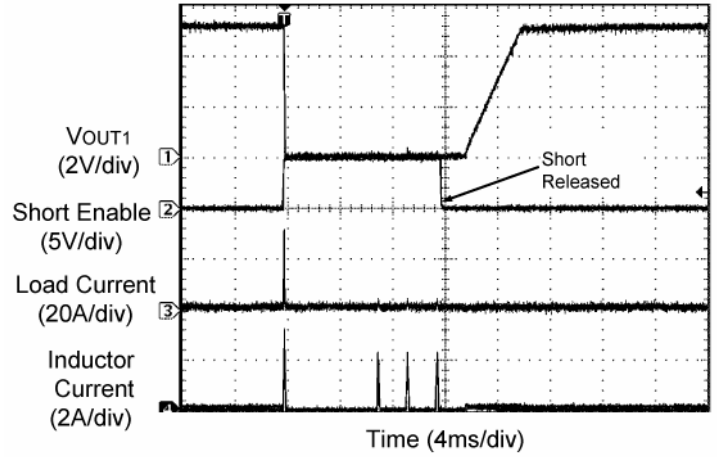

**Bode Plot MIC24420  
(12V to 5V @ 1.5A)**

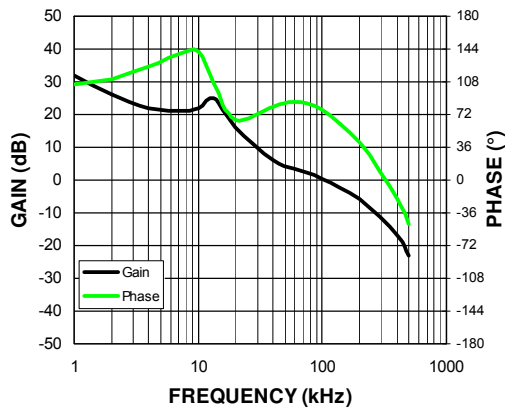

**Bode Plot MIC24421  
(12V to 5V @ 1.5A)**

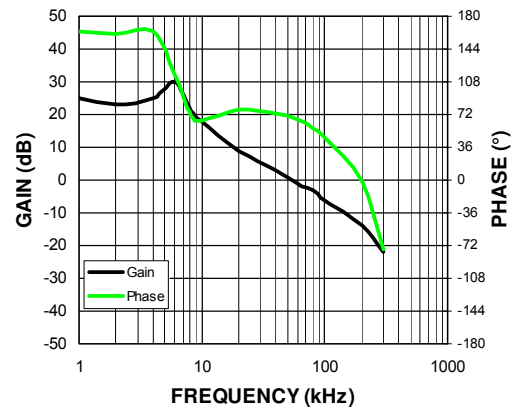

# Functional Diagram

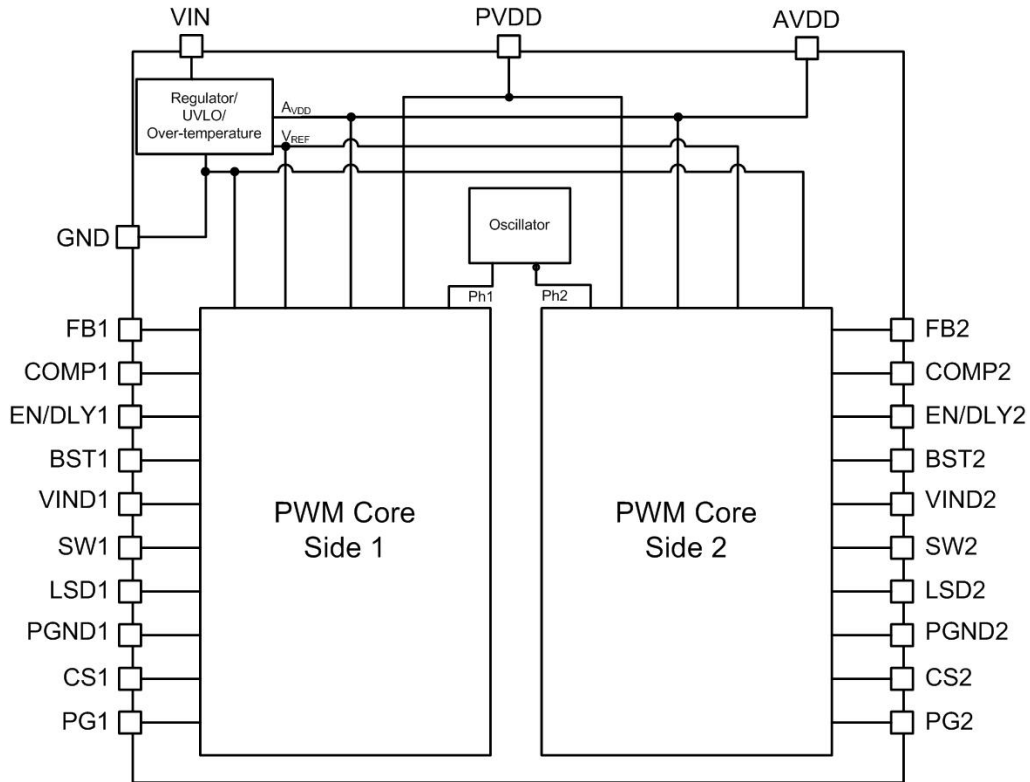

## PWM Core

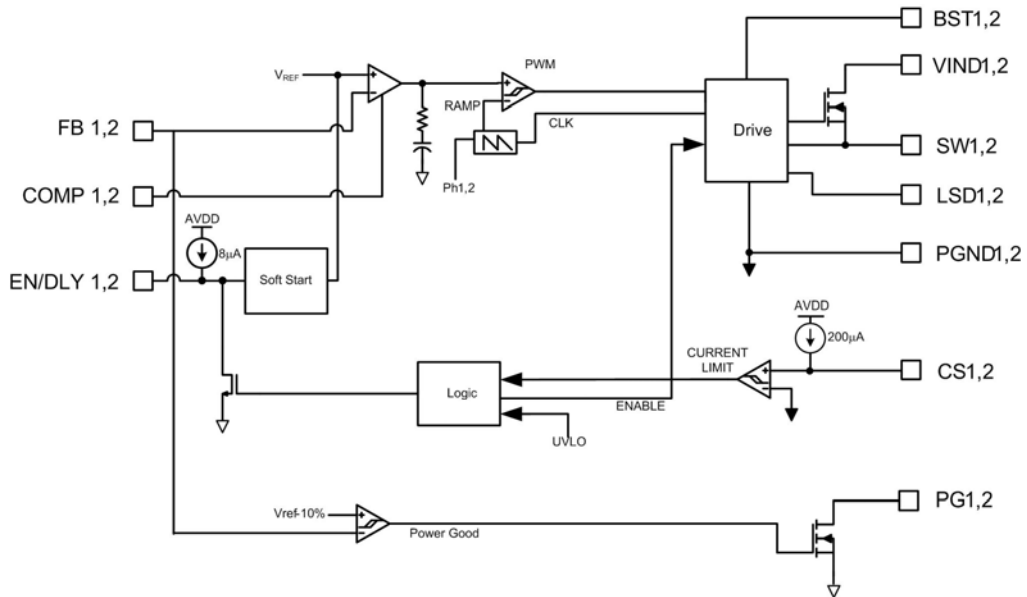

MIC24420 Block Diagram

## Functional Description

The MIC24420/MIC24421 are dual output, synchronous buck regulators. Output regulation is performed using a fixed frequency, voltage mode control scheme. The fixed frequency clock drives the two sections 180° out of phase, which reduces input ripple current.

### Oscillator

An internal oscillator provides a clock signal to each of the two sides. The clock signals are 180° out of phase with the other. Each phase is used to generate a ramp for the PWM comparator and a clock pulse that terminates the switching cycle. The MIC24420 & MIC24421 oscillator frequencies are nominally 1MHz and 500 kHz respectively.

### UVLO

The UVLO monitors voltage on the VIN pin. The circuit controls both regulators (side1 and side2). It disables the output drivers and discharges the EN/DLY capacitor when VIN is below the UVLO threshold. As VIN rises above the threshold, the internal high-side FET drivers and external low-side drives are enabled and the EN/DLY pins are released.

A low impedance source should be used to supply input voltage to the MIC24420/MIC24421. When VIN drops below the UVLO threshold and the outputs turn off, the change in input current will cause VIN to rise. The output voltage will momentarily turn back on if the rise in VIN is greater than the UVLO hysteresis.

The preferred method is to use the EN/DLY pins, as shown in Figure 1, for startup and shutdown of the outputs. This avoids the possibility of glitching during startup and shutdown. If an external control signal is not available, the circuit in Figure 1A may be used to set a higher turn-on and turn-off threshold than the internal UVLO circuit. Moreover, the hysteresis is adjustable and can accommodate a wider input source impedance range. Please refer to the MIC841 datasheet for additional information on selecting the resistor values.

### Regulator/Reference

The internal regulator generates an AVDD pin voltage that powers the internal analog circuit blocks of the low level analog and digital sections. The AVDD voltage is also used by the bandgap to generate a nominal 700mV for the error amplifier reference. The output undervoltage and power good circuits use the bandgap for their references. PVDD powers the high-side MOSFET and low-side gate drive circuits.

The dropout of the internal regulator causes AVDD to drop when VIN is below 6V. When operating below 6V, the AVDD pin must be jumpered to VIN. This bypasses the internal LDO and prevents AVDD from dropping out.

A 4.7µF ceramic capacitor should be used to decouple AVDD to ground.

### EN/DLY pin

The EN/DLY pins are used to turn on, turn off and soft-start the outputs. The pins can be controlled with an open collector or open drain device as shown in Figure 1. It must not be actively driven high or damage will result. When disabling the output with an external device, the enable pin turn-off time must be less than 1µs.

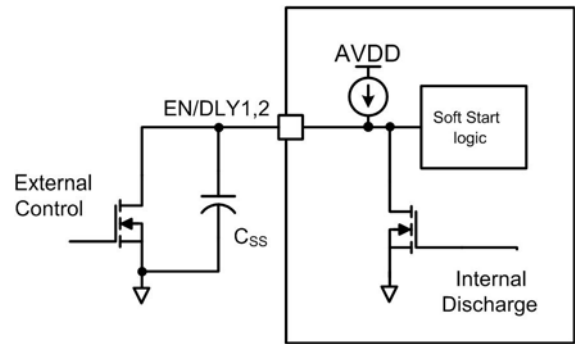

Figure 1. Enable and soft-start circuit

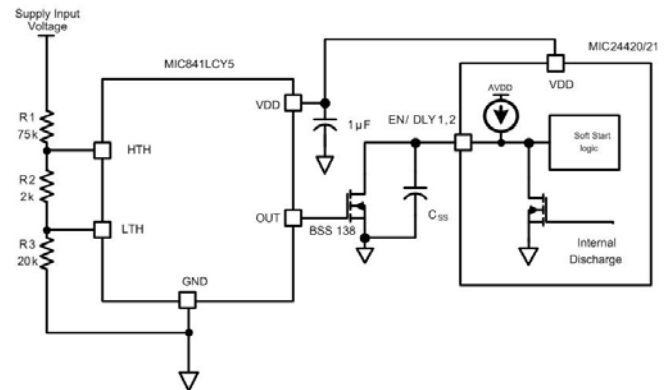

Figure 1A. Adjustable UVLO startup circuit

### Minimum Output Load when Disabled

When one output is disabled and the other enabled, the disabled output requires a minimum output load to prevent its output voltage from rising. Typically a 2kΩ load on the output will keep the output voltage below 100mV. The output setting voltage divider resistors may be used for the 2kΩ load if the total resistance is set low enough. A separate output resistor should be used for lower output voltages since the voltage divider resistance becomes impractically low.

**Soft-start**

Enable and soft-start waveforms are shown in Figure 2.

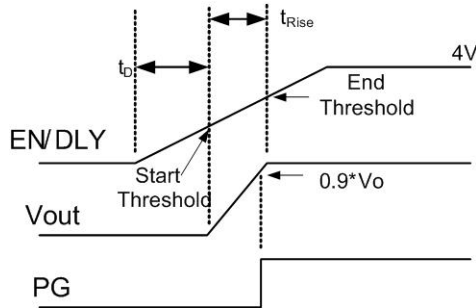

**Figure 2. Soft-start Timing Diagram**

A capacitor,  $C_{SS}$ , is connected to the EN/DLY pin. The  $C_{SS}$  capacitor range is 4.7nF to 22nF. Releasing the pin allows an internal current source to charge the capacitor. The delay ( $t_D$ ) between the EN/DLY pin release and when  $V_{OUT}$  starts to rise can be calculated by the equation below.

$$t_D = \frac{C_{SS} \times V_{Threshold\_Start}}{I_{SS}}$$

Where:

$C_{SS}$  is the soft-start capacitor.

$I_{SS}$  is the internal soft-start current (7 $\mu$ A nominal).

$V_{Threshold\_start}$  is the EN/DLY pin voltage where the output starts to rise (1.35V nominal).

The output voltage starts to rise when voltage on the EN/DLY pin reaches the start threshold. The output voltage reaches regulation when the EN/DLY pin voltage reaches the end threshold. The output voltage rise time ( $t_R$ ) can be calculated by the equation below:

$$t_R = \frac{C_{SS} \times (V_{Threshold\_End} - V_{Threshold\_Start})}{I_{SS}}$$

Where:

$V_{Threshold\_End}$  is the EN/DLY pin voltage where the output reaches regulation (2.4V nominal).

As the MIC24420/MIC24421 uses a fold-back, hiccup mode current limit, care should be taken to select  $t_R$  to ensure startup. See application information for details.

**Power Good**

Power good is an open drain signal that asserts when  $V_{OUT}$  exceed the power good threshold. The circuit monitors the FB pin. The internal FET is turned on while the FB voltage is below the FB threshold. When voltage on the FB in exceeds the FB threshold, the FET is turned off. A pull-up resistor can be connected to PVDD or an external source. The external source voltage must not exceed the maximum rating of the pin. The PG pin

can be connected to another regulator’s EN/DLY pin for sequencing of the outputs. A pull-up resistor is not used when the power good pin is connected to another regulators EN/DLY pin.

**Output Sequencing**

Sequencing of the outputs can be easily implemented as shown in Figure 3. The power good pin is used to disable  $V_{OUT2}$  until the  $V_{OUT1}$  reaches regulation. Sequencing waveforms are shown in Figure 4.

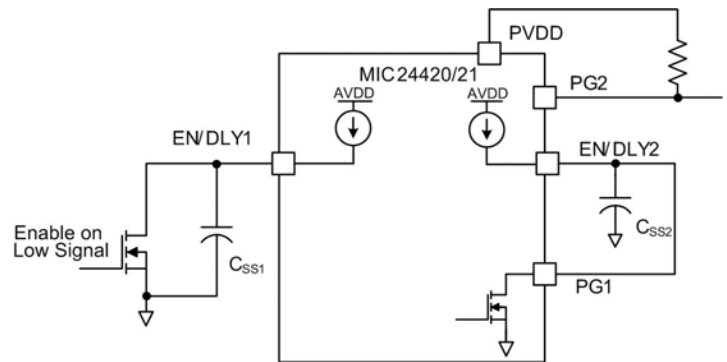

**Figure 3. Output Sequencing**

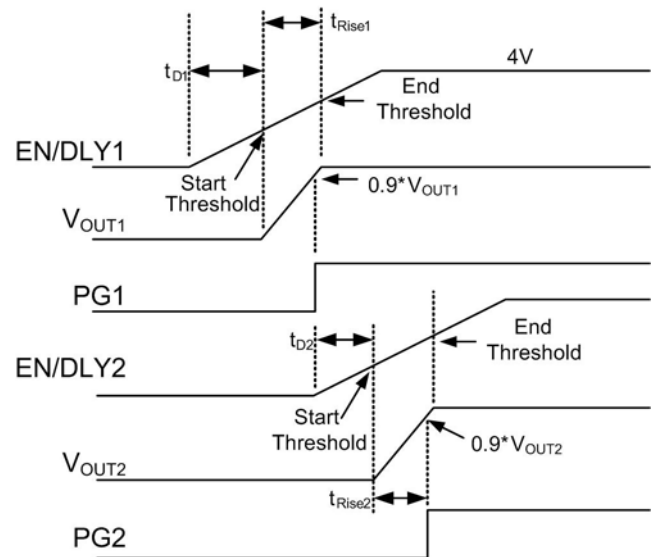

**Figure 4. Output Sequencing Waveforms**

### High-side Drive

The internal high-side drive circuit is designed to switch the internal N-channel MOSFET. Figure 5 shows a diagram of the high-side MOSFET, gate drive and bootstrap circuit. D2 and C<sub>BST</sub> comprise the bootstrap circuit, which supplies drive voltage to the high-side MOSFET. Bootstrap capacitor C<sub>BST</sub> is charged through diode D2 when the low-side MOSFET turns on and pulls the SW pin voltage to ground. When the high-side MOSFET driver is turned on, energy from C<sub>BST</sub> charges the MOSFET gate, turning it on. Voltage on the SW pin increases to approximately V<sub>IN</sub>. Diode D2 is reversed biased and C<sub>BST</sub> flies high while maintaining gate voltage on the high-side MOSFET.

A resistor should be added in series with the BST1 and BST2 pins. This will slow down the turn-on time of the high-side MOSFET while leaving the turn-off time unaffected. Slowing down the MOSFET risetime will reduce the turn-on overshoot at the switch node, which is important when operating with an input voltage close to the maximum operating voltage.

The recommended capacitor for C<sub>BST</sub> is a 0.01µF ceramic capacitor. The recommended value for R<sub>BST</sub> is 20Ω to 60Ω.

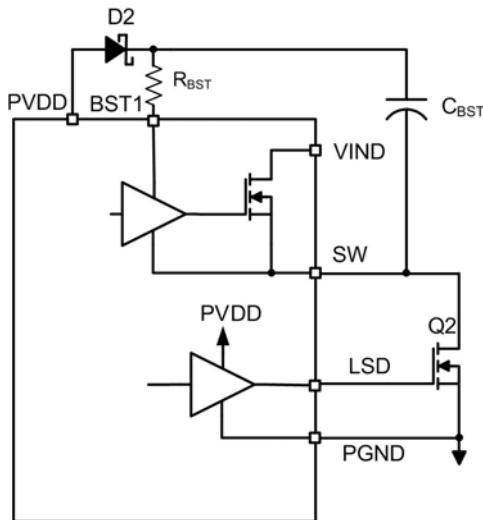

Figure 5. High-side Drive Circuitry

### Low-side Drive Output

The LSD pin is used to drive an external MOSFET. This MOSFET is driven out of phase with the internal high-side MOSFET to conduct inductor current during the high-side MOSFET's off-time. Circuitry internal to the regulator prevents short circuit “shoot-through” current from flowing by preventing the high-side and low-side MOSFETs conducting at the same time.

The low-side MOSFET gate voltage is supplied from PVDD. Turn off of the MOSFET is accomplished by

discharging the gate through the LSD pin. The return path is through the PGND pin and back to the MOSFET's Source pin. These circuit paths must be kept short to minimize noise. See the layout section for additional information.

Driving the low-side MOSFET on and off dissipates power in the MIC24420/21 regulator. The power can be calculated by the equation below:

$$P_{DRIVER} = Q_G \times V_{IN} \times f_S$$

Where:

P<sub>DRIVER</sub> is the power dissipated in the regulator by switching the MOSFET on and off.

Q<sub>G</sub> is the total Gate charge of the MOSFET at V<sub>GS</sub> = P<sub>VDD</sub>.

V<sub>IN</sub> is the input voltage to the internal A<sub>VDD</sub> regulator.

f<sub>S</sub> is the switching frequency of the regulator (1MHz/500kHz nominal).

### dV/dt Induced Turn-on of the Low-side MOSFET

As the high-side MOSFET turns on, the rising dv/dt on the switch-node forces current through C<sub>GD</sub> of the low-side MOSFET causing a glitch on its gate. Figure 6 demonstrates the basic mechanism causing this issue. If the glitch on the gate is greater than the MOSFET's turn-on threshold, it may cause an unwanted turn-on of the low-side MOSFET while the high-side MOSFET is on. A short circuit between input and ground would momentarily occur, which lowers efficiency and increases power dissipation in both MOSFETs. Additionally, turning on the low-side MOSFET during the off-time could interfere with overcurrent sensing.

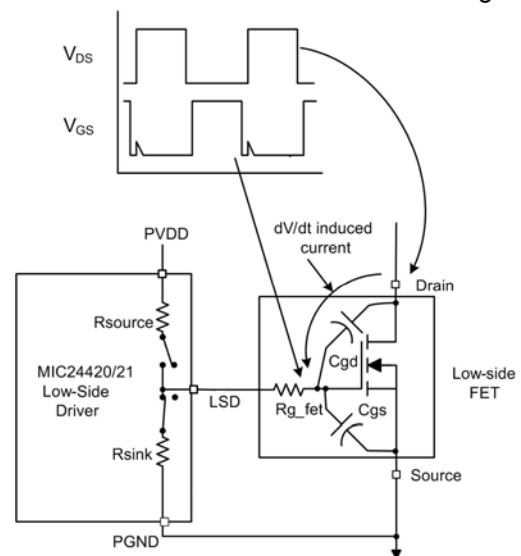

Figure 6. dV/dt induced turn-on of the low-side MOSFET



### Voltage Setting Components

The regulator requires two external resistors to set the output voltage as shown in Figure 8.

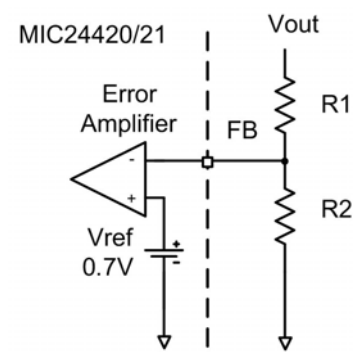

Figure 8. Setting the Output Voltage

The output voltage is determined by the equation below.

$$V_{OUT} = V_{REF} \times \left(1 + \frac{R1}{R2}\right)$$

Where:  $V_{REF}$  is 0.7V nominal.

If the voltage divider resistance is used to provide the minimum load (see EN/DLY section) then R1 should be low enough to provide the necessary impedance.

Once R1 is selected, R2 can be calculated with the following formula.

$$R2 = \frac{V_{REF} \times R1}{V_{OUT} - V_{REF}}$$

And

$$R2 + R1 < 2k\Omega$$

### Minimum Pulse Width

Output voltage is regulated by adjusting the on-time pulse width of the high-side MOSFET. This is accomplished by comparing the error amplifier output with a sawtooth waveform (see block diagram). The pulse width output of the comparator becomes smaller as the error amplifier voltage decreases. Due to propagation delay and other circuit limitations, there is a minimum pulse width at the output of the comparator. If the error amplifier voltage drops any further, the output of the comparator will be low.

The PWM circuit will skip pulses if a smaller duty cycle is required to maintain output voltage regulation. This effectively cuts the output frequency in half.

### Thermal Protection

The internal temperature of the regulator is monitored to prevent damage to the device. Both outputs are inhibited from switching if the over-temperature threshold is exceeded. Hysteresis in the circuit allows the regulator to cool before turning back on.



## Application Information

### Component Selection

#### Inductor

The value of inductance is determined by the peak-to-peak inductor current. Higher values of inductance reduce the inductor current ripple at the expense of a larger inductor. Smaller inductance values allow faster response to output current transients but increase the output ripple voltage and require more output capacitance.

The inductor value and saturation current are also controlled by the method of overcurrent limit used (see explanation in the previous section). The minimum value of inductance for the MIC24420/MIC24421 is 10 $\mu$ H/22 $\mu$ H.

The peak-to-peak ripple current may be calculated using the formula below.

$$I_{PP} = \frac{V_{OUT} \cdot (\eta \cdot V_{IN(max)} - V_{OUT})}{\eta \cdot V_{IN(max)} \cdot f_S \cdot L}$$

Where:

$I_{PP}$  is the peak-to-peak inductor ripple current

$L$  is the value of inductance

$f_S$  is the switching frequency of the regulator

$\eta$  is the efficiency of the power supply

Efficiency values from the Functional Characteristics section can be used for these calculations.

The peak inductor current in each channel is equal to the average output current plus one half of the peak to peak inductor ripple current.

$$I_{PK} = I_{OUT} + 0.5 \times I_{PP}$$

The RMS inductor current is used to calculate the  $I^2R$  losses in the inductor.

$$I_{INDUCTOR_{RMS}} = I_{OUT} \cdot \sqrt{1 + \frac{1}{3} \left( \frac{I_{PP}}{I_{OUT}} \right)^2}$$

Maximizing efficiency requires the proper selection of core material and minimizing the winding resistance. The high frequency operation of the MIC24420/MIC24421 requires the use of ferrite materials. Lower cost iron powder cores may be used but the increase in core loss will reduce the efficiency of the power supply. This is especially noticeable at low output power. The inductor winding resistance decreases efficiency at the higher output current levels. The winding resistance must be minimized although this usually comes at the expense of a larger inductor.

The power dissipated in the inductor equals the sum of the core and copper losses. Core loss information is

usually available from the magnetics vendor.

#### Input Capacitor

A 10 $\mu$ F ceramic is suggested on each of the  $V_{IN}$  pins for bypassing. X5R or X7R dielectrics are recommended for the input capacitor. Y5V dielectrics should not be used. Besides losing most of their capacitance over temperature, they also become resistive at high frequencies, which reduce their ability to filter out high frequency noise.

#### Output Capacitor

The MIC24420/MIC24421 regulator is designed for ceramic output capacitors although tantalum and Aluminum Electrolytic may also be used.

Output ripple voltage is determined by the magnitude of inductor current ripple, the output capacitor's ESR and the value of output capacitance. When using ceramic output capacitors, the primary contributor to output ripple is the value of capacitance. Output ripple using ceramic capacitors may be calculated using the equation below:

$$C_{OUT} \geq \frac{I_{PP}}{8 \cdot \Delta V_{OUT} \cdot 2 \cdot f_S}$$

Where:

$\Delta V_{OUT}$  is the peak-to-peak output voltage ripple

$I_{PP}$  is the peak-to-peak ripple current as seen by the capacitors

$f_S$  is the switching frequency (1MHz nominal).

When using tantalum or aluminum electrolytic capacitors, both the capacitance and ESR contribute to output ripple. The total ripple is calculated below:

$$\Delta V_{OUT} = \sqrt{\left[ \frac{I_{PP}}{8 \cdot C_{OUT} \cdot 2 \cdot f_S} \right]^2 + [I_{PP} \cdot R_{ESR}]^2}$$

The output capacitor RMS current is calculated below:

$$I_{COUT_{RMS}} = \frac{I_{PP}}{\sqrt{12}}$$

The power dissipated in the output capacitors can be calculated by the equation below:

$$P_{DISS_{COUT}} = (I_{COUT_{RMS}})^2 \cdot R_{ESR}$$

#### Soft start capacitor considerations:

Where a large amount of capacitance is present at the output of the regulator, a fast rising output voltage can, in extreme circumstances (since  $I=Cdv/dt$ ), cause current limit to operate and prevent startup. In order to avoid this situation, the following equation can be used to ensure  $t_R$  (output rise time) is set correctly.

$$C_{SS} > \frac{C_{OUT} \cdot V_{OUT} \cdot I_{SS}}{I_{S/C}}$$

Where

$I_{S/C}$  is the short circuit, fold-back current limit.

$C_{SS}$  is the capacitor connected to EN/DLY pin

$I_{SS}$  is the EN/DLY pull up current.

**Current Limit Resistor**

The current limit circuit responds to the peak inductor current flowing through the low-side FET. Calculating the current setting resistor  $R_{CS}$  should take into account the peak inductor current and the blanking delay of approximately 100ns.

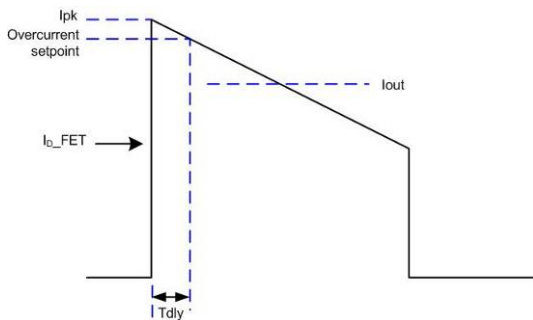

**Figure 9. Overcurrent waveform**

Figure 9 shows the low-side MOSFET current waveform. Peak current is measured after a small delay. The equations used to calculate the current limit resistor value are shown below:

$$I_{PK} = I_{OUT} \cdot \frac{I_{PP}}{2}$$

$$I_{OC} = I_{PK} - \frac{V_{OUT} \cdot t_{DLY}}{L}$$

$$R_{CS} = \frac{I_{OC} \cdot R_{DS(ON)}}{I_{CS}}$$

Where:

$I_{OC}$  is the current limit set point

$L$  = inductor value

$t_{DLY}$  = Current limit blanking time ~ 100ns

$I_{CS}$  is the overcurrent pin sense current (200µA nominal)

$R_{DS(ON)}$  is the on resistance of the low-side MOSFET

**Short Circuit Protection**

It is recommended that a fold-back current characteristic be implemented to protect both external and internal MOSFETs during short circuit (S/C) events. This can be achieved by the addition of one additional resistor  $R_{FBK}$  (R14 & R19 on the evaluation board) from  $V_{OUT}$  to the CS pin.

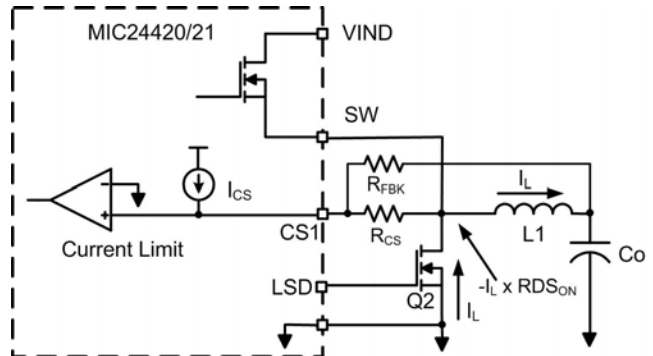

**Figure 9a. Short Circuit Protection**

Current limit will occur at:

$$I_{OC} = \frac{1}{R_{DS(ON)}} \cdot \left( I_{CS} \cdot R_{CS} + \frac{V_{OUT} \cdot R_{CS}}{R_{FBK}} - V_{CS\_OFF} \right)$$

Where  $V_{CS\_OFF}$  is the CS comparator offset voltage.

For simplicity, assuming  $V_{CS\_OFF}$  is 0V, we can set  $I_{S/C}$  (current limit when  $V_{OUT} = 0V$ ) to be half  $I_{OC}$  (current limit when  $V_{OUT} =$  nominal):

$$R_{CS} = \frac{I_{OC} \cdot R_{DS(ON)}}{I_{CS} \cdot 2}$$

$$R_{FBK} = \frac{V_{OUT}}{I_{CS}}$$

To determine worst case values, one must take into account  $V_{CS}$  offset voltage,  $I_{CS}$  range and the range of values for  $R_{DS(ON)}$  over the operating temperature range.

Some typical example values for a 30mΩ MOSFET:

$V_{OUT}$	$I_{OC}$	$I_{S/C}$	$R_{CS}$	$R_{FBK}$
5	3.3A	1.7	249	24.9k
	4.3A	1.7	249	16k
3.3	3.3A	1.7	249	16.5k
	4.3A	1.7	249	10.5k
1.2	3.3A	1.7	249	5.1k
	4.3A	1.7	249	3.83k

Due to the leading edge blanking, a 100ns slew rate for the CS pin can be applied without interfering with current limit operation. Limiting the CS pin's slew rate will help to prevent false triggering. A C-R product of at least 20ns should be used.

E.G. Where  $R_{CS} = 250\Omega$ ,  $C_{CS} = 82pF$

**Snubber**

A snubber is used to damp out high frequency ringing caused by parasitic inductance and capacitance in the buck converter circuit. Figure 10 shows a simplified schematic of one of the buck converter phases. Stray capacitance consists mostly of the output capacitance ( $C_{OSS}$ ) of the two MOSFET's. The stray inductance is mostly package and etch inductance. The arrows show the resonant current path when the high-side MOSFET turns on. This ringing causes stress on the semiconductors in the circuit as well as increased EMI.

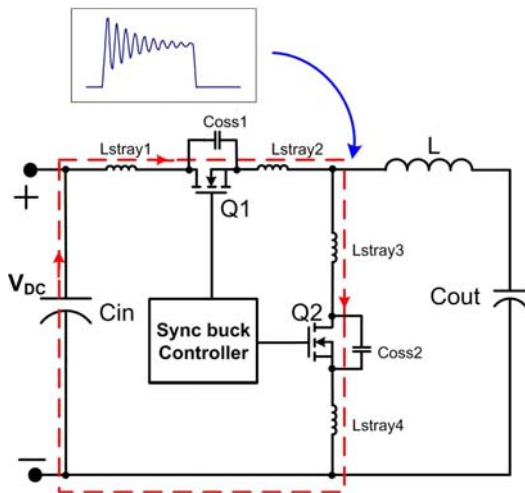

**Figure 10. Output Parasitics**

One method of reducing the ringing is to use a resistor to lower the Q of the resonant circuit. The circuit in Figure 11 shows an RC network connected between the switch node and ground. Capacitor  $C_S$  is used to block DC and minimize the power dissipation in the resistor. This capacitor value should be between 5 and 10 times the parasitic capacitance of the MOSFET  $C_{OSS}$ . A capacitor that is too small will have high impedance and prevent the resistor from damping the ringing. A capacitor that is too large causes unnecessary power dissipation in the resistor, which lowers efficiency.

The snubber components should be placed as close as possible to the low-side MOSFET and/or external Schottky diode since it contributes to most of the stray capacitance. Placing the snubber too far from the MOSFET or using traces that are too long or too thin adds inductance to the snubber and diminishes its effectiveness.

Proper snubber design requires the parasitic inductance and capacitance be known. A method of determining these values and calculating the damping resistor value

is outlined below.

1. Measure the ringing frequency at the switch node which is determined by parasitic  $L_P$  and  $C_P$ . Define this frequency as  $f_1$ .
2. Add a capacitor  $C_S$  (normally at least 3 times as big as the  $C_{OSS}$  of the FET) from the switch node to ground and measure the new ringing frequency. Define this new (lower) frequency as  $f_2$ .  $L_P$  and  $C_P$  can now be solved using the values of  $f_1$ ,  $f_2$  and  $C_S$ .
3. Add a resistor  $R_S$  in series with  $C_S$  to generate critical damping.

**Step 1:** First measure the ringing frequency on the switch node voltage when the high-side MOSFET turns on. This ringing is characterized by the equation:

$$f_1 = \frac{1}{2\pi\sqrt{L_P \cdot C_P}}$$

Where:

$C_P$  and  $L_P$  are the parasitic capacitance and inductance

**Step 2:** Add a capacitor,  $C_S$ , in parallel with the synchronous MOSFET, Q2. The capacitor value should be approximately 3 times the  $C_{OSS}$  of Q2. Measure the frequency of the switch node ringing,  $f_2$ .

$$f_2 = \frac{1}{2\pi\sqrt{L_P \cdot (C_S + C_P)}}$$

Define  $f'$  as:

$$f' = \frac{f_1}{f_2}$$

Combining the equations for  $f_1$ ,  $f_2$  and  $f'$  to derive  $C_P$ , the parasitic capacitance

$$C_P = \frac{C_S}{2 \cdot (f')^2 - 1}$$

$L_P$  is solved by re-arranging the equation for  $f_1$ .

$$L_P = \frac{1}{(2\pi)^2 \cdot C_P \cdot (f_1)^2}$$

**Step 3:** Calculate the damping resistor.

Critical damping occurs at  $Q=1$

$$Q = \frac{1}{R_S} \sqrt{\frac{L_P}{C_S + C_P}} = 1$$

Solving for  $R_S$

$$R_S = \sqrt{\frac{L_P}{C_S + C_P}}$$

Figure 11 shows the snubber in the circuit and the

damped switch node waveform.

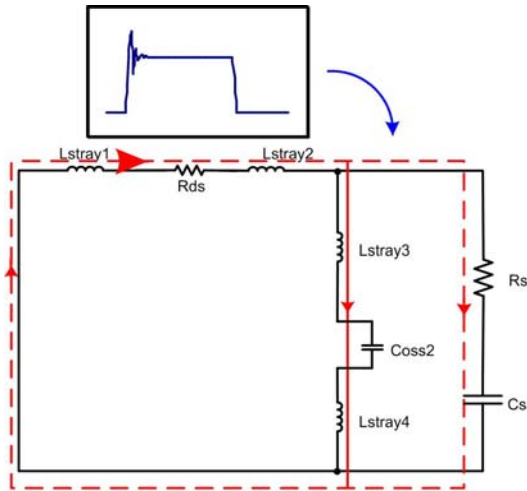

Figure 11. Snubber Circuit

The snubber capacitor,  $C_S$ , is charged and discharged each switching cycle. The energy stored in  $C_S$  is dissipated by the snubber resistor,  $R_S$ , two times per switching period. This power is calculated in the equation below.

$$P_{\text{snubber}} = f_S \cdot C_S \cdot V_{\text{IN}}^2$$

Where:

$f_S$  is the switching frequency for each phase

$V_{\text{IN}}$  is the DC input voltage

### Low-side MOSFET Selection

An external N-channel logic level power MOSFET must be used for the low-side switch. The MOSFET gate to source drive voltage of the MIC24420/MIC24421 is regulated by an internal 5V regulator. Logic level MOSFETs, whose operation is specified at  $V_{\text{GS}} = 4.5\text{V}$  must be used. Use of MOSFETs with a lower specified  $V_{\text{GS}}$  (such as 3.3V or 2.5V) are not recommended since the low threshold can cause them to turn on when the high-side FET is turning on. When operating the regulator below a 6V input, connect  $V_{\text{DD}}$  to  $V_{\text{IN}}$  to prevent the  $V_{\text{DD}}$  regulator from dropping out.

Total gate charge is the charge required to turn the MOSFET on and off under specified operating conditions ( $V_{\text{DS}}$  and  $V_{\text{GS}}$ ). The gate charge is supplied by the regulator's gate drive circuit. Gate charge is a source of power dissipation in the regulator due to the high switching frequencies. At low output load this power dissipation is noticeable as a reduction in efficiency. The average current required to drive the MOSFETs is:

$$I_{\text{DD}} = Q_G \cdot f_S$$

Where:

$Q_G$  is the gate charge for both of the external MOSFETs. This information should be obtained from the manufacturer's data sheet.

Since current from the gate drive is supplied by the input voltage, power dissipated in the MIC24420/MIC24421 due to gate drive is:

$$P_{\text{GATE\_DRIVE}} = Q_G \cdot f_S \cdot V_{\text{IN}}$$

Parameters that are important to MOSFET selection are:

- Voltage rating
- On resistance
- Total gate charge

The MOSFET is subjected to a  $V_{\text{DS}}$  equal to the input voltage. A safety factor of 20% should be added to the  $V_{\text{DS(max)}}$  of the MOSFET to account for voltage spikes due to circuit parasitics. Generally, 30V MOSFETs are recommended for all applications since lower  $V_{\text{DS}}$  rated MOSFETs tend to have a  $V_{\text{GS}}$  rating that is lower than the recommended 4.5V.

### RMS Current and MOSFET Power Dissipation Calculation

Switching loss in the low-side MOSFET can be neglected since it is turned on and off at a  $V_{\text{DS}}$  of 0V. The power dissipated in the MOSFET is mostly conduction loss during the on-time ( $P_{\text{CONDUCTION}}$ ).

$$P_{\text{CONDUCTION}} = I_{\text{SW\_RMS}}^2 \cdot R_{\text{DS(ON)}}$$

Where:

$R_{\text{DS(ON)}}$  is the on resistance of the MOSFET switch.

The RMS value of the MOSFET current is:

$$I_{\text{SW\_RMS}} = \sqrt{(1-D) \cdot (I_{\text{OUT\_MAX}}^2 + \frac{I_{\text{PP}}^2}{12})}$$

Where:

$D$  is the duty-cycle of the converter

$I_{\text{PP}}$  is the inductor ripple current

$$D = \frac{V_{\text{OUT}}}{\eta \cdot V_{\text{IN}}}$$

Where:

$\eta$  is the efficiency of the converter.

### External Schottky Diode

A freewheeling diode in parallel with the low-side MOSFET is needed to maintain continuous inductor current flow while both MOSFETs are turned off (dead-time). Dead-time is necessary to prevent current from flowing unimpeded through both MOSFETs. An external Schottky diode is used to bypass the low-side MOSFET's parasitic body diode. An external diode

improves efficiency due to its lower forward voltage drop as compared to the internal parasitic diode in the MOSFET. It may also decrease high frequency noise because the schottky diode junction does not suffer from reverse recovery.

An external Schottky diode conducts at a lower forward voltage preventing the body diode in the MOSFET from turning on. The lower forward voltage drop dissipates less power than the body diode. Depending on the circuit components and operating conditions, an external Schottky diode may give up to 1% improvement in efficiency.

**Compensation**

The voltage regulation, filter and power stage sections are shown in Figure 12. The error amplifier regulates the output voltage and compensates the voltage regulation loop. It is a simplified type III compensator utilizing two compensating zeros and two poles. Figure 12 also shows the transfer function for each section.

Compensation is necessary to insure the control loop has adequate bandwidth and phase margin to properly respond to input voltage and output current transients. High gain at DC and low frequencies is needed for accurate output voltage regulation. Attenuation near the switching frequency prevents switching frequency noise from interfering with the control loop.

The output filter contains a complex double pole formed by the capacitor and inductor and a zero from the output capacitor and its ESR. The transfer function of the filter is:

$$G_{filter}(s) = \frac{1 + \frac{s}{\omega Z}}{1 + \frac{s}{Q \cdot \omega O} + \frac{s}{\omega O}^2}$$

Where:

$$\omega Z = \frac{1}{C_O \cdot R_{ESR}}$$

$$\omega O = \frac{1}{\sqrt{C_O \cdot L_O}}$$

$$Q = R \cdot \sqrt{\frac{C_O}{L}}$$

The Modulator gain is proportional to the input voltage and inversely proportional to the internal ramp voltage generated by the oscillator. The peak-to-peak ramp voltage is 1V.

$$G_{mod} = \left( \frac{V_{IN}}{V_{RAMP}} \right)$$

The output voltage divider attenuates  $V_{OUT}$  and feeds it back to the error amplifier. The divider gain is:

$$H = \frac{R4}{R1 + R4} = \frac{V_{REF}}{V_{OUT}}$$

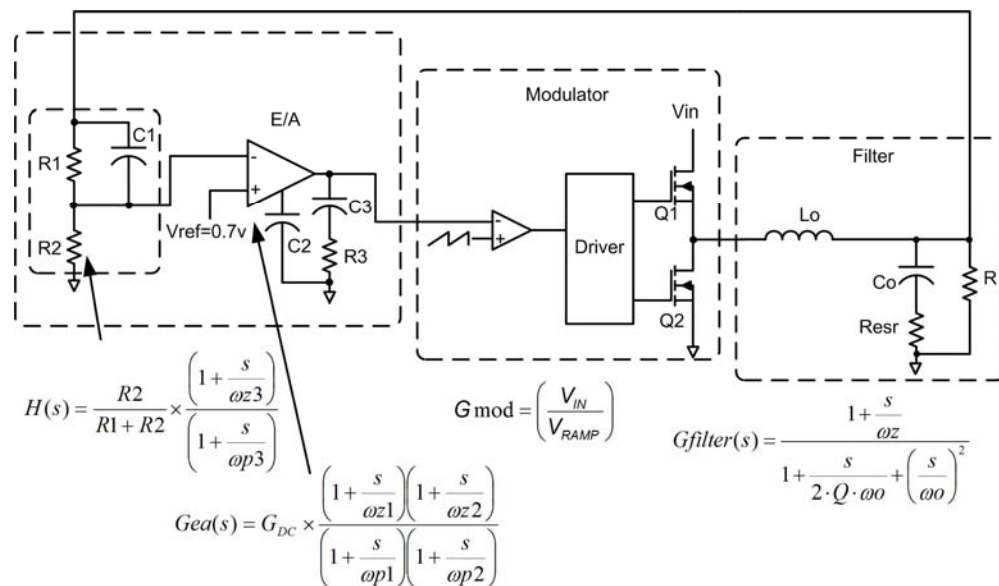

**Figure 12. Voltage Loop and Transfer Functions**

The modulator, filter and voltage divider gains can be multiplied together to show the open loop gain of these parts.

$$G_{vd}(s) = G_{filter}(s) \cdot H \cdot G_{mod}$$

This transfer function is plotted in Figure 13. At low frequency, the transfer function gain equals the modulator gain times the voltage divider gain. As the frequency increases toward the LC filter resonant frequency, the gain starts to peak. The increase in the gain's amplitude equals Q. Just above the resonant frequency, the gain drops at a -40db/decade rate. The phase quickly drops from 0° to almost 180° before the phase boost of the zero brings it back up to -90°. Higher values of Q will cause the phase to drop quickly. In a well damped, low Q system the phase will change more slowly.

As the Gain/Phase plot approaches the zero frequency (f<sub>z</sub>), formed by C<sub>O</sub> and its ESR, the slope of the gain curve changes from -40db/dec. to -20db/dec and the phase increases. The zero causes a 90° phase boost. Ceramic capacitors, with their smaller values of capacitance and ESR, push the zero and its phase boost out to higher frequencies, which allow the phase lag from the LC filter to drop closer to -180°. The system will be close to being unstable if the overall open loop gain crosses 0dB while the phase is close to -180°.

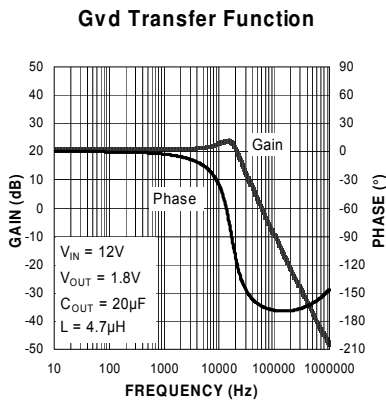

Figure 13: Gvd Transfer Function

If the output capacitance and/or ESR is high, the zero moves lower in frequency and helps to boost the phase, leading to a more stable system.

**Error Amplifier Poles and Zeros**

The error amplifier has internal poles and zeros that can be shifted in frequency with an external capacitor. The general form of the error amplifier compensation is shown in the equation below:

$$G_{ea}(s) = G_{DC} \times \frac{\left(1 + \frac{s}{\omega_{z1}}\right) \left(1 + \frac{s}{\omega_{z2}}\right)}{\left(1 + \frac{s}{\omega_{p1}}\right) \left(1 + \frac{s}{\omega_{p2}}\right)}$$

The G<sub>DC</sub> is the DC gain of the error amplifier. It is internally set to 2500 (68dB).

As illustrated in Figure 12, there are two compensating zeros. ω<sub>z1</sub> is internally set with R3 and C3. The zero frequency is fixed at a nominal 16kHz in the MIC24420/MIC24421. The second zero, ω<sub>z2</sub>, is set by the external capacitor, C2.

For the MIC24420:

$$R3 = 100k$$

$$C3 = 100pf$$

$$f_{z1} = \frac{1}{2 \times \pi \times R3 \times C3} = 16kHz$$

$$f_{z2} = \frac{1}{2 \times \pi \times 21 \cdot 10^3 \times C2}$$

The two compensating pole frequencies are shown below.

$$f_{p1} = 250Hz$$

$$f_{p2} = \frac{1}{2 \times \pi \times 12 \cdot 10^3 \times C2}$$

f<sub>p2</sub> and f<sub>z2</sub> both depend on the value of C2 and are proportionally spaced in frequency with the zero at a lower frequency than the pole. This provides gain and phase boost in the control loop.

**Voltage Divider Feedforward Capacitor**

The capacitor across the upper voltage divider resistor boosts the gain and phase of the control loop by short circuiting the high-side resistor at higher frequencies. The capacitor and upper resistor form a zero at a lower frequency. The capacitor and parallel combination of upper and lower resistors form a pole at a higher frequency. This phase boost circuit is most effective at higher output voltages, where there is a larger attenuation from the voltage divider resistors.

The general form of the feedforward circuit is shown below.

$$H(s) = \frac{R2}{R1 + R2} \times \left( 1 + \frac{s}{\omega z3} \right) \left( 1 + \frac{s}{\omega p3} \right)$$

Where:

$$fz3 = \frac{1}{2 \times \pi \times R1 \times C1}$$

$$fp3 = \frac{1}{2 \times \pi \times C1 \times \left( \frac{R1 \times R2}{R1 + R2} \right)}$$

The total open loop transfer function is:

$$T(s) = Gea(s) \times Gmod \times Gfilter(s) \times H(s)$$

The following tables list the recommended values of compensation and filter components for different output voltages. The output capacitors are ceramic.

**MIC24420**

V <sub>OUT</sub>	R1	R2	C7/8	C16/17	R22/23	C29/30	L <sub>MIN</sub>	Co <sub>MIN</sub>
1.0V	1k	2.32k	220pF	3.3nF	NF	NF	10μH	47μF
1.2V	1k	1.4k	220pF	3.3nF	NF	NF	10μH	47μF
1.4V	1k	1k	220pF	3.3nF	NF	NF	10μH	47μF
1.8V	1k	634	150pF	4.7nF	NF	NF	10μH	47μF
2.5V	1k	383	150pF	10nF	NF	NF	10μH	47μF
3.3V	1k	274	150pF	10nF	NF	NF	10μH	47μF
5.0V	1k	162	150pF	10nF	NF	NF	10μH	47μF

**MIC24421**

V <sub>OUT</sub>	R1	R2	C7/8	C16/17	R22/23	C29/30	L <sub>MIN</sub>	Co <sub>MIN</sub>
1.0V	1k	2.32k	1000pF	22nF	22k	100nF	22μH	100μF
1.2V	1k	1.4k	1000pF	22nF	22k	100nF	22μH	100μF
1.4V	1k	1k	1000pF	22nF	22k	100nF	22μH	100μF
1.8V	1k	634	1000pF	22nF	22k	100nF	22μH	100μF
2.5V	1k	383	1000pF	22nF	22k	100nF	22μH	100μF
3.3V	1k	274	1000pF	22nF	22k	100nF	22μH	100μF
5.0V	1k	162	1000pF	22nF	22k	100nF	22μH	100μF

## PCB Layout Guidelines

**Warning!!! To minimize EMI and output noise, follow these layout recommendations.**

PCB Layout is critical to achieve reliable, stable and efficient performance. A ground plane is required to control EMI and minimize the inductance in power, signal and return paths.

The following guidelines should be followed to insure proper operation of the MIC24420/MIC24421 converter.

### IC

- Place the IC and the external Low-side MOSFET close to the point of load (POL).
- Use fat traces to route the input and output power lines.
- The exposed pad (EP) on the bottom of the IC must be connected to the ground.
- Use several vias to connect the EP to the ground plane on layer 2.
- Signal and power grounds should be kept separate and connected at only one location, the EP ground of the package.
- The following signals and their components should be decoupled or referenced to the power ground plane: VIND1, VIND2, PVDD, PGND1, PGND2, LSD1, and LSD2.
- These analog signals should be referenced or decoupled to the analog ground plane: VIN, EN/DLY1, EN/DLY2, COMP1, COMP2, FB1, and FB2.
- Place the overcurrent sense resistor close to the CS1 or CS2 pins. The trace coming from the switch node to this resistor has high dv/dt and should be routed away from other noise sensitive components and traces. Avoid routing this trace under the inductor to prevent noise from coupling into the signal.

### Input Capacitor

- Place the input capacitor next. Ceramic capacitors must be placed between VIND1 and PGND1 and between VIND2 and PGND2.
- Place the input capacitors on the same side of the board and as close to the IC and low-side MOSFET as possible.
- Keep both the VIN and PGND connections short.
- Place several vias to the ground plane close to the input capacitor ground terminal, but not between the input capacitors and IC pins.
- Use either X7R or X5R dielectric input capacitors. Do not use Y5V or Z5U type capacitors.

- Do not replace the ceramic input capacitor with any other type of capacitor. Any type of capacitor can be placed in parallel with the input capacitor.
- If a Tantalum input capacitor is placed in parallel with the input capacitor, it must be recommended for switching regulator applications and the operating voltage must be derated by 50%.
- In “Hot-Plug” applications, a Tantalum or Electrolytic bypass capacitor must be used to limit the over-voltage spike seen on the input supply with power is suddenly applied. The value must be sufficiently large to prevent this voltage spike from exceeding the maximum voltage rating of the MIC24420/MIC24421.
- An additional Tantalum or Electrolytic bypass input capacitor of 22 $\mu$ F or higher is required at the input power connection.

### Inductor

- Keep the inductor connection to the switch node (SW) short.
- Do not route any digital or analog signal lines underneath or close to the inductor.
- Keep the switch node (SW) away from the feedback (FB) pin.
- To minimize noise, place a ground plane underneath the inductor.

### Output Capacitor

- Use a wide trace to connect the output capacitor ground terminal to the input capacitor ground terminal.
- Phase margin will change as the output capacitor value and ESR changes. Contact the factory if the output capacitor is different from what is shown in the BOM.
- The feedback trace should be separate from the power trace and connected as close as possible to the output capacitor. Sensing a long high current load trace can degrade the DC load regulation.
- If 0603 package ceramic output capacitors are used, then make sure that it has enough capacitance at the desired output voltage. Please refer to the capacitor datasheet for more details.

### Diode

- The external Schottky diode is placed next to the low-side MOSFET.
- The connection from the Schottky diode's Anode to the input capacitors ground terminal must be as short as possible.
- The diode's Cathode connection to the switch node



(SW) must be kept as short as possible.

**RC Snubber**

- Place the RC snubber on the same side of the board and as close as possible to the low-side MOSFET.

**Low-side MOSFET**

- Low-side drive MOSFET traces (LSD pin to MOSFET gate pin) must be short and routed over a ground plane. The ground plane should be the connection between the MOSFET source and PGND.
- Choose a low-side MOSFET with a high  $C_{GS}/C_{GD}$  ratio and a low internal gate resistance to minimize

the effect of  $dv/dt$  inducted turn-on.

- Do not put a resistor between the LSD output and the gate.
- Use a 4.5V  $V_{GS}$  rated MOSFET. Its higher gate threshold voltage is more immune to glitches than a 2.5V or 3.3V rated MOSFET. MOSFETs that are rated for operation at less than  $4.5V_{GS}$  should not be used.

**High-side MOSFET**

- Add a 20 to 60 ohm resistor in series with the boost pin. This will slow down the turn-on time of the high-side MOSFET while leaving the turn-off time unaffected.

# MIC24420 Evaluation Board Schematic

