



Chipsmall Limited consists of a professional team with an average of over 10 year of expertise in the distribution of electronic components. Based in Hongkong, we have already established firm and mutual-benefit business relationships with customers from,Europe,America and south Asia,supplying obsolete and hard-to-find components to meet their specific needs.

With the principle of “Quality Parts,Customers Priority,Honest Operation,and Considerate Service”,our business mainly focus on the distribution of electronic components. Line cards we deal with include Microchip,ALPS,ROHM,Xilinx,Pulse,ON,Everlight and Freescale. Main products comprise IC,Modules,Potentiometer,IC Socket,Relay,Connector.Our parts cover such applications as commercial,industrial, and automotives areas.

We are looking forward to setting up business relationship with you and hope to provide you with the best service and solution. Let us make a better world for our industry!



Contact us

Tel: +86-755-8981 8866 Fax: +86-755-8427 6832

Email & Skype: info@chipsmall.com Web: www.chipsmall.com

Address: A1208, Overseas Decoration Building, #122 Zhenhua RD., Futian, Shenzhen, China





MIC2775

Micro-Power Voltage Supervisor

IttyBitty®

General Description

The MIC2775 is a power supply supervisor that provides undervoltage monitoring, manual reset capability, and power-on reset generation in a compact 5-pin SOT package. Features include an undervoltage detector, a delay generator, a manual reset input, and both active-high and active-low reset outputs. The undervoltage detector compares V_{DD} against a fixed threshold. Ten factory-programmed thresholds are available.

The reset outputs are asserted for no less than 140ms at power-on and any time the input voltage drops below the reference voltage. It remains asserted for the timeout period after the input voltage subsequently rises back above the threshold boundary. A reset can be generated at any time by asserting the manual reset input, /MR. This reset output will remain active at least 140ms after the release of /MR. The /MR input can also be used to daisy-chain the MIC2775 onto existing power monitoring circuitry or other supervisors. Hysteresis is included to prevent chattering due to noise. Typical supply current is an ultra-low 3.5 μ A.

Datasheets and support documentation are available on Micrel's website at: www.micrel.com.

Features

- Monitors power supply for undervoltage conditions
- Choice of factory-programmed thresholds
- Generates 140ms (minimum) power-on reset pulse
- Manual reset capability
- Both active-high and active-low reset outputs
- /RST output valid down to 1.2V
- Ultra-low supply current, 3.5 μ A typical
- Rejects brief input transients
- No external components
- For extended temperature range see Micrel's MAX825
- IttyBitty® 5-pin SOT-23 package

Applications

- Monitoring processor core and input/output voltages
- Computer systems
- PDAs, handheld PCs
- Embedded controllers
- Telecommunications systems
- Power supplies

Typical Application

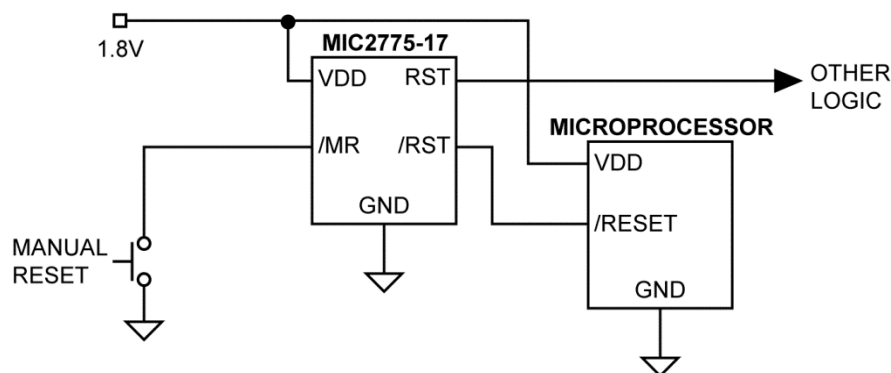

IttyBitty is a registered trademark of Micrel, Inc.

Micrel Inc. • 2180 Fortune Drive • San Jose, CA 95131 • USA • tel +1 (408) 944-0800 • fax + 1 (408) 474-1000 • <http://www.micrel.com>

Ordering Information

Part Number ^(1,2)	Marking ^(1,3)	Junction Temperature Range	Package ⁽⁴⁾
MIC2775-XXYM5	<u>UJ</u> XX	-40°C to +85°C	SOT-23-5

Note:

1. XX = Voltage Code, see [Part Numbering Conventions](#) below. There are ten standard versions available with an order increment of 3,000 pieces. Samples of standard versions are normally available from stock. Contact factory for information on non-standard versions. Available in tape-and-reel only.
2. Order entry part number add a space, then TR. Example: MIC2775-22YM5 TR.
3. Underbar () symbol may not be to scale.
4. Standard reel SOT-23: Reel diameter is 7 inches, hub diameter is 2 inches, width is 8mm.

Part Numbering Conventions

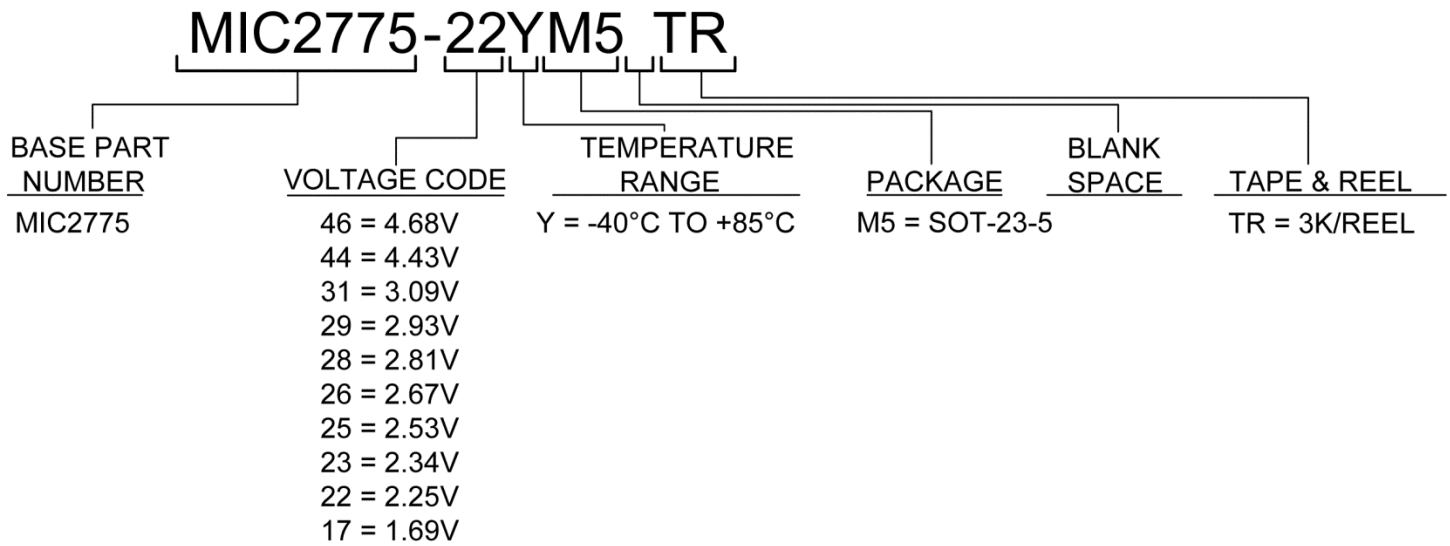

Pin Configuration

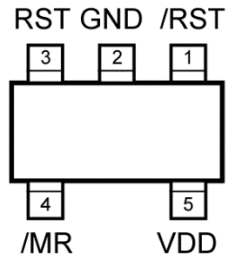

**SOT-23-5 (M5)
(Top View)**

Pin Description

Pin Number	Pin Name	Pin Function
1	/RST	Digital (Output): Asserted low whenever V_{DD} falls below the reference voltage. It will remain asserted for no less than 140ms after V_{DD} returns above the threshold limit.
2	GND	Ground.
3	RST	Digital (Output): Asserted high whenever V_{DD} falls below the reference voltage. It will remain asserted for no less than 140ms after V_{DD} returns above the threshold limit.
4	/MR	Digital (Input): Driving this pin low initiates an immediate and unconditional reset. Assuming V_{DD} is above the threshold when /MR is released (returns high), the reset output will be de-asserted no less than 140ms later. /MR has an internal pull-up to V_{DD} and may be left open if unused.
5	VDD	Analog (Input): Power supply input and the voltage being monitored.

Absolute Maximum Ratings⁽⁵⁾

Supply Voltage (V_{DD})	-0.3V to +7.0V
Output Voltage (V_{MR})	-0.3V to +7.0V
RST, (/RST) Current	20mA
Storage Temperature (T_s)	-65°C to +150°C
ESD Rating ⁽⁷⁾	1.5kV

Operating Ratings⁽⁶⁾

Supply Voltage (V_{DD})	+1.5V to +5.5V
Input Voltage (V_{MR})	-0.3V to +6.0V
Ambient Temperature (T_A)	-40°C to +85°C
Package Thermal Resistance (θ_{JA})	256°C/W

Electrical Characteristics⁽⁸⁾

$T_A = 25^\circ\text{C}$, **bold** values indicate $-40^\circ\text{C} \leq T_A \leq +85^\circ\text{C}$, unless noted.

Symbol	Parameter	Condition	Min.	Typ.	Max.	Units
I_{DD}	Supply Current	$V_{DD} = V_{TH} + 1.6\%$, /MR, RST, /RST open,		3.5		μA
VDD Voltage Threshold						
	Undervoltage Threshold on VDD		$V_{TH-1.5\%}$	V_{TH}	$V_{TH+1.5\%}$	V
V_{HYST}	Hysteresis Voltage			1		%
RST, /RST Outputs						
t_{PROP}	Propagation Delay	$V_{DD} = V_{TH} + 1.5\% + 100\text{mV}$ to $V_{DD} = V_{TH} - 1.5\% - 100\text{mV}$		20		μs
t_{RST}	Reset Pulse Width		140		280	ms
V_{OL}	RST or /RST Output Voltage Low	$I_{SINK} = 1.6\text{mA}$; $V_{DD} \geq 1.6\text{V}$			0.3	V
		$I_{SINK} = 100\mu\text{A}$; $V_{DD} \geq 1.2\text{V}$; Note 9			0.3	V
V_{OH}	RST or /RST Output Voltage High	$I_{SOURCE} = 500\mu\text{A}$; $V_{DD} \geq 1.5\text{V}$	$0.8V_{DD}$			V
		$I_{SOURCE} = 10\mu\text{A}$; $V_{DD} \geq 1.2\text{V}$; Note 9	$0.8V_{DD}$			V
/MR Input						
V_{IH}	Input High Voltage		$0.7V_{DD}$			V
V_{IL}	Input Low Voltage				$0.3V_{DD}$	V
t_{PROP}	Propagation Delay	From $V_{MR} < (V_{IL} - 100\text{mV})$		5		μs
t_{MIN}	Minimum Input Pulse Width	Reset occurs, $V_{MR} < V_{IL}$		33		ns
I_{PU}	Internal Pull-up Current			100		nA
I_{IN}	Input Current, /MR	$V_{MR} < V_{IL}$		100		nA

Notes:

- Exceeding the absolute maximum ratings may damage the device.
- The device is not guaranteed to function outside its operating ratings.
- Devices are ESD sensitive. Handling precautions are recommended. Human body model, 1.5k Ω in series with 100pF.
- Specification for packaged product only.
- V_{DD} operating range is 1.5V to 5.5V. Output is guaranteed to be asserted down to $V_{DD} = 1.2\text{V}$.

Timing Diagram

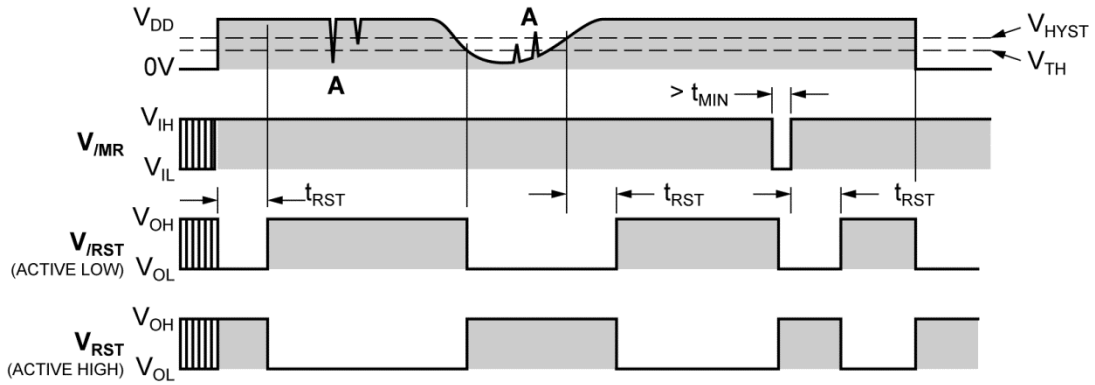

Note: Propagation delays not shown for clarity.

A = The MIC2775 ignores very brief transients. See the [Application Information](#) section for details.

Functional Diagram

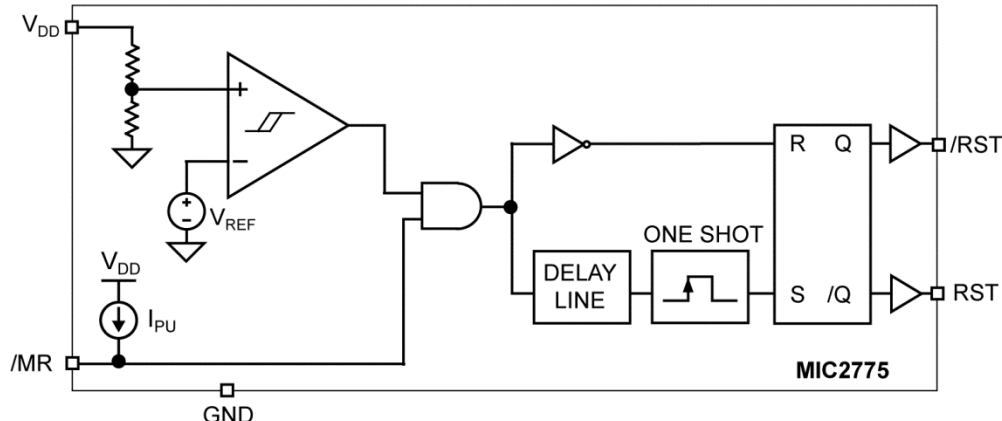

Functional Description

VDD Input

The VDD pin is both the power supply terminal and a monitored input voltage. The voltage at this pin is continually compared against the internal reference. The trip-point at which a reset occurs is factory-programmed. A reset is triggered if and when V_{DD} falls below the trip-point. Hysteresis is employed to prevent chattering due to noise. The comparator on the VDD input is relatively immune to very brief negative-going transients.

RST, /RST Reset Outputs

Typically, the MIC2775 is used to monitor the power supply of intelligent circuits such as microcontrollers and microprocessors. By connecting the appropriate reset output of an MIC2775 to the reset input of a μC or μP , the processor will be properly reset at power-on, power-down, and brown-out conditions. In addition, asserting /MR, the manual reset input, will activate the reset function.

The reset outputs are asserted any time /MR is asserted or if V_{DD} drops below the threshold voltage. The reset outputs remain asserted for $t_{RST(min)}$ after V_{DD} subsequently returns above the threshold boundary and/or /MR is released. A reset pulse is also generated at power-on. Hysteresis is included in the comparator to prevent chattering of the outputs due to noise.

/MR, Manual Reset Input

The ability to initiate a reset via external logic or a manual switch is provided in addition to the MIC2775's automatic supervisory functions. Driving the /MR input to a logic-low causes an immediate and unconditional reset to occur. Assuming V_{DD} is within tolerance when /MR is released (returns high), the reset outputs will be de-asserted no less than t_{RST} later. /MR may be driven by a logic signal or mechanical switch. Typically, a momentary push-button switch is connected such that /MR is shorted to ground when the switch contact close. The switch may be connected directly between /MR and GND. /MR has an internal 100nA pull-up current to VDD and may be left open if unused.

Application Information

Ensuring Proper Operation at Low Supply

At V_{DD} levels below 1.2V, the MIC2775's /RST output cannot turn on sufficiently to produce a valid logic-low on /RST. In this situation, circuits driven by /RST could be allowed to float, causing undesired operation. In most cases, however, it is expected that the circuits driven by the MIC2775 will be similarly inoperative at $V_{DD} \leq 1.2V$.

If a given application requires that /RST be valid below $V_{DD} = 1.2V$, this can be accomplished by adding a pull-down resistor to the /RST output. A value of 100k Ω is recommended as this is usually an acceptable compromise of quiescent current and pull-down current. The resistor's value is not critical, however. See Figure 1.

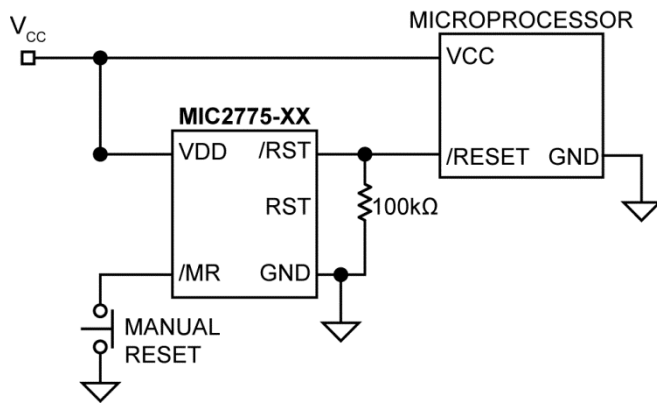

Figure 1. MIC2775 Valid /RST Below 1.2V

The statements above also apply to the MIC2775's RST output. That is, to ensure valid RST signal levels when $V_{DD} < 1.2V$, a pull-up resistor (as opposed to a pull-down) should be added to the RST output. A value of 100k Ω is typical for this application, as well. See Figure 2.

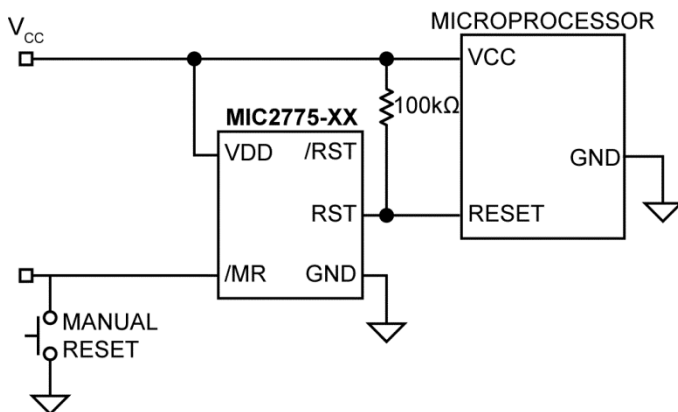

Figure 2. MIC2775 Valid RST Below 1.2V

Transient Response

The MIC2775 is inherently immune to very short negative-going glitches. Very brief transients may exceed the voltage threshold without tripping the output.

In general, as shown in Figure 3, the narrower the transient, the deeper the threshold overdrive that will be ignored by the MIC2775. The graph represents the typical allowable transient duration for a given amount of threshold overdrive that will not generate a reset.

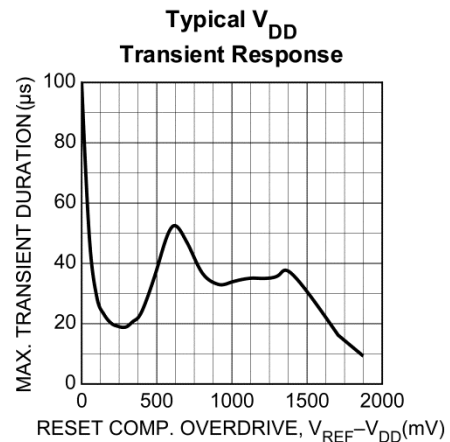
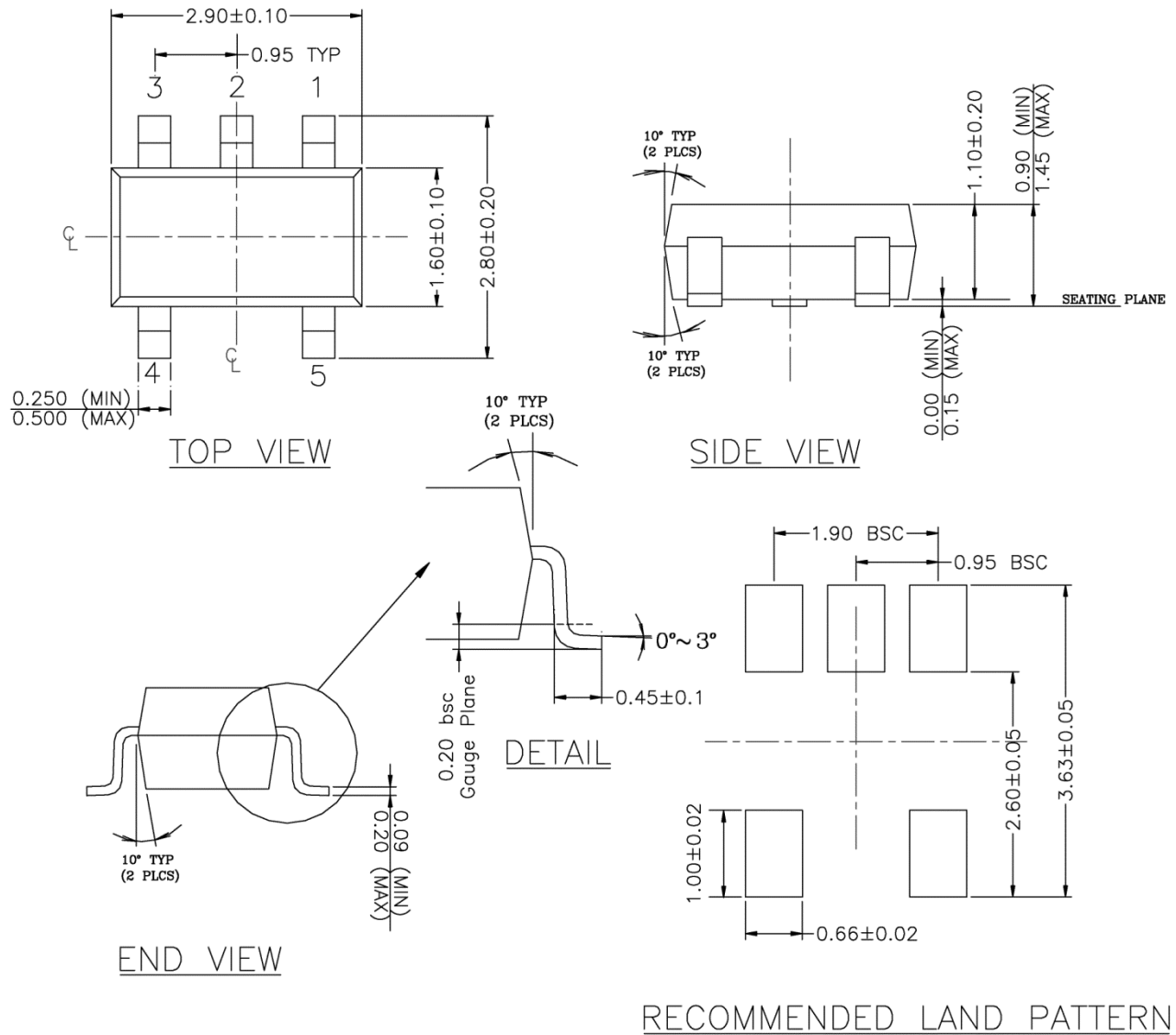

Figure 3. Typical VDD Transient Response

Package Information and Recommended Landing Pattern⁽¹⁰⁾



- NOTE:
1. PACKAGE OUTLINE EXCLUSIVE OF MOLD FLASH & BURR.
 2. PACKAGE OUTLINE INCLUSIVE OF SOLER PLATING.
 3. DIMENSION AND TOLERANCE PER ANSI Y14.5M, 1982.
 4. FOOT LENGTH MEASUREMENT BASED ON GAUGE PLANE METHOD.
 5. DIE FACES UP FOR MOLD, AND FACES DOWN FOR TRIM/FORM.
 6. ALL DIMENSIONS ARE IN MILLIMETERS.

SOT-23-5 (M5)

Note:

10. Package information is correct as of the publication date. For updates and most current information, go to www.micrel.com.

MICREL, INC. 2180 FORTUNE DRIVE SAN JOSE, CA 95131 USA
TEL +1 (408) 944-0800 FAX +1 (408) 474-1000 WEB <http://www.micrel.com>

Micrel, Inc. is a leading global manufacturer of IC solutions for the worldwide high performance linear and power, LAN, and timing & communications markets. The Company's products include advanced mixed-signal, analog & power semiconductors; high-performance communication, clock management, MEMs-based clock oscillators & crystal-less clock generators, Ethernet switches, and physical layer transceiver ICs. Company customers include leading manufacturers of enterprise, consumer, industrial, mobile, telecommunications, automotive, and computer products. Corporation headquarters and state-of-the-art wafer fabrication facilities are located in San Jose, CA, with regional sales and support offices and advanced technology design centers situated throughout the Americas, Europe, and Asia. Additionally, the Company maintains an extensive network of distributors and reps worldwide.

Micrel makes no representations or warranties with respect to the accuracy or completeness of the information furnished in this datasheet. This information is not intended as a warranty and Micrel does not assume responsibility for its use. Micrel reserves the right to change circuitry, specifications and descriptions at any time without notice. No license, whether express, implied, arising by estoppel or otherwise, to any intellectual property rights is granted by this document. Except as provided in Micrel's terms and conditions of sale for such products, Micrel assumes no liability whatsoever, and Micrel disclaims any express or implied warranty relating to the sale and/or use of Micrel products including liability or warranties relating to fitness for a particular purpose, merchantability, or infringement of any patent, copyright, or other intellectual property right.

Micrel Products are not designed or authorized for use as components in life support appliances, devices or systems where malfunction of a product can reasonably be expected to result in personal injury. Life support devices or systems are devices or systems that (a) are intended for surgical implant into the body or (b) support or sustain life, and whose failure to perform can be reasonably expected to result in a significant injury to the user. A Purchaser's use or sale of Micrel Products for use in life support appliances, devices or systems is a Purchaser's own risk and Purchaser agrees to fully indemnify Micrel for any damages resulting from such use or sale.

© 2000 Micrel, Incorporated.