



Chipsmall Limited consists of a professional team with an average of over 10 year of expertise in the distribution of electronic components. Based in Hongkong, we have already established firm and mutual-benefit business relationships with customers from,Europe,America and south Asia,supplying obsolete and hard-to-find components to meet their specific needs.

With the principle of “Quality Parts,Customers Priority,Honest Operation,and Considerate Service”,our business mainly focus on the distribution of electronic components. Line cards we deal with include Microchip,ALPS,ROHM,Xilinx,Pulse,ON,Everlight and Freescale. Main products comprise IC,Modules,Potentiometer,IC Socket,Relay,Connector.Our parts cover such applications as commercial,industrial, and automotives areas.

We are looking forward to setting up business relationship with you and hope to provide you with the best service and solution. Let us make a better world for our industry!



## Contact us

Tel: +86-755-8981 8866 Fax: +86-755-8427 6832

Email & Skype: info@chipsmall.com Web: www.chipsmall.com

Address: A1208, Overseas Decoration Building, #122 Zhenhua RD., Futian, Shenzhen, China





# MIC4043

## Low-Voltage, Secondary-Side Shunt Regulator

### General Description

The MIC4043 is a shunt regulator optimized for secondary-side regulation in low-voltage power supplies. Featuring an output stage guaranteed to swing within 400mV of ground, the MIC4043 can be used in power supplies operating down to 1.8V, even with opto-isolators requiring greater than 1.2V of headroom.

In power supply applications, the MIC4043 normally drives the LED of an optically isolated feedback circuit. The MIC4043 monitors a resistively-divided output voltage and sinks error current through the opto-isolator's LED (secondary side); the opto-isolator's transistor (primary side) provides this signal to the controller's feedback input. The MIC4043 is also practical for other voltage-monitoring applications requiring an open-collector output.

The MIC4043 replaces conventional '431-type shunt regulators to allow low-voltage applications where there is inadequate headroom for a 2.5V regulator in series with an opto-isolator. Replacing '431-type devices requires only a minor change to the way that the resistive-divider values are calculated.

Datasheets and support documentation are available on Micrel's web site at: [www.micrel.com](http://www.micrel.com).

### Features

- Ideal for 1.8V switching converters
- Low-voltage operation:
  - 400mV maximum saturation over operating temperature range
- Easy-to-use
  - Voltage in, current out
- 2% voltage tolerance over operating temperature range

### Applications

- Optically-isolated, low-voltage power supplies
- Low-voltage discrete regulator control

### Typical Application

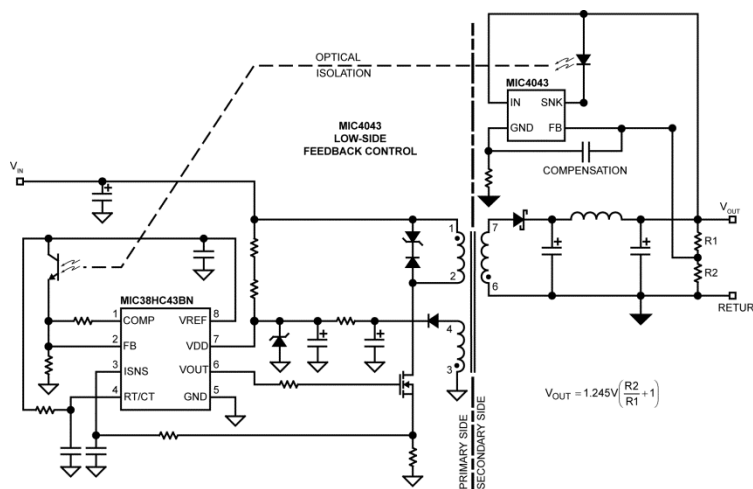

200kHz DC-to-DC Flyback Converter

## Ordering Information

Part Number <sup>(1)</sup>	Marking	Voltage (V)	Tolerance	Configuration	Temperature Range	Package
MIC4043YM4	<u>RB1D</u>	1.245	1%	Open Collector	-40°C to +85°C	SOT-143

### Note:

- Underbar (   ) symbol may not be to scale.

## Pin Configuration

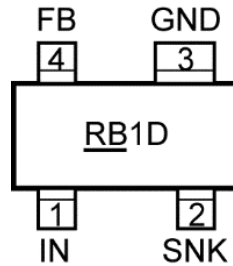

SOT-143 (M4)  
(Top View)

## Pin Description

Pin Number	Pin Name	Pin Function
1	IN	Input: Supply voltage input.
2	SNK	Sink (Output): NPN open collector output.
3	GND	Ground
4	FB	Feedback (Input): Feedback input from external voltage-divider network.

**Absolute Maximum Ratings<sup>(2)</sup>**

Input Voltage ( $V_{IN}$ )	+15V
Output Voltage ( $V_{SNK}$ )	+15V
Storage Temperature ( $T_S$ )	-65°C to +150°C
ESD Rating <sup>(4)</sup>	
Human Body Model	2kV
Machine Model	200V

**Operating Ratings<sup>(3)</sup>**

Input Voltage ( $V_{IN}$ )	+10V
Output Voltage ( $V_{SNK}$ )	+10V
Maximum Output Current ( $I_{SNK}$ )	15mA
Temperature Range ( $T_A$ )	-40°C to +85°C

**Electrical Characteristics<sup>(5)</sup>**

$T_A = +25^\circ\text{C}$ , **bold** values indicate  $-40^\circ\text{C} \leq T_A \leq +85^\circ\text{C}$ , unless noted.

Parameter	Condition	Min.	Typ.	Max.	Units
Reference Voltage <sup>(5)</sup>			1.245		V
Reference Voltage Tolerance				±1	%
				<b>±2</b>	
Supply Current	$I_{SNK} = 0\text{mA}$		35	65	$\mu\text{A}$
				<b>70</b>	
Transconductance ( $\Delta I_{SNK} / \Delta V_{IN}$ )	$1\text{mA} < I_{SNK} < 15\text{mA}$	3.5	150		S
Output Transistor Saturation Voltage	$I_{SNK} = 15\text{mA}$		160	250	mV
				<b>400</b>	
Output Leakage	$V_{SNK} = 5\text{V}$ , output transistor off			0.5	$\mu\text{A}$
				<b>1</b>	

**Notes:**

- Exceeding the absolute maximum ratings may damage the device.
- The device is not guaranteed to function outside its operating ratings.
- Devices are ESD sensitive. Handling precautions are recommended. Human body model, 1.5k $\Omega$  in series with 100pF. Machine model, 200pF.
- Reference voltage is not referenced to ground. The reference is between the IN and FB pins.

# Test Circuit

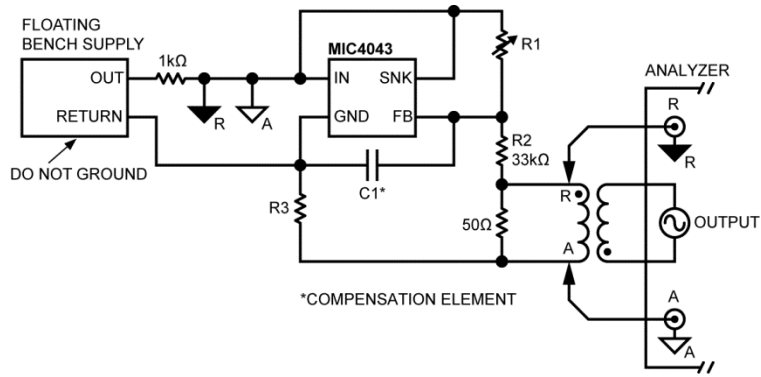

$V_{OUT}$	R1	R2	R3	C1
1.8V	72kΩ	33kΩ	20kΩ	0.001μF
2.5V	33kΩ	33kΩ	40kΩ	0.001μF
3.3V	20kΩ	33kΩ	150kΩ	0.001μF

**Test Circuit 1: Compensation (Bode Plot) Circuit**

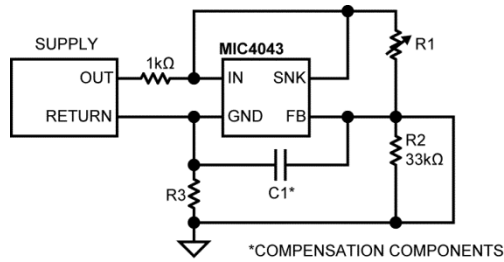

**Test Circuit 2: Transient Response Circuit**



### Functional Characteristics

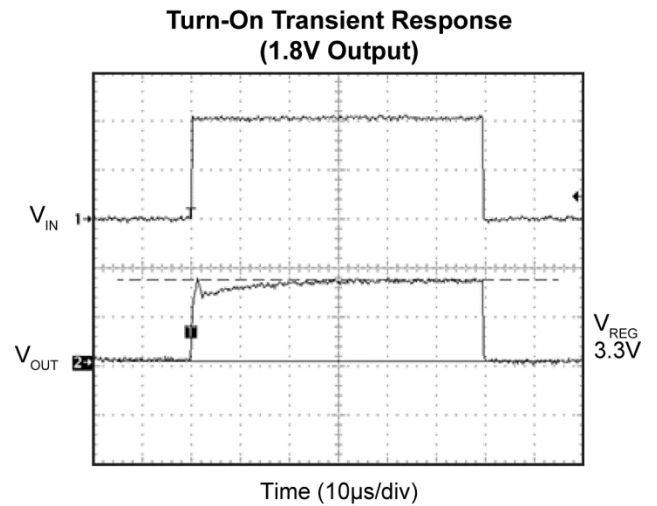
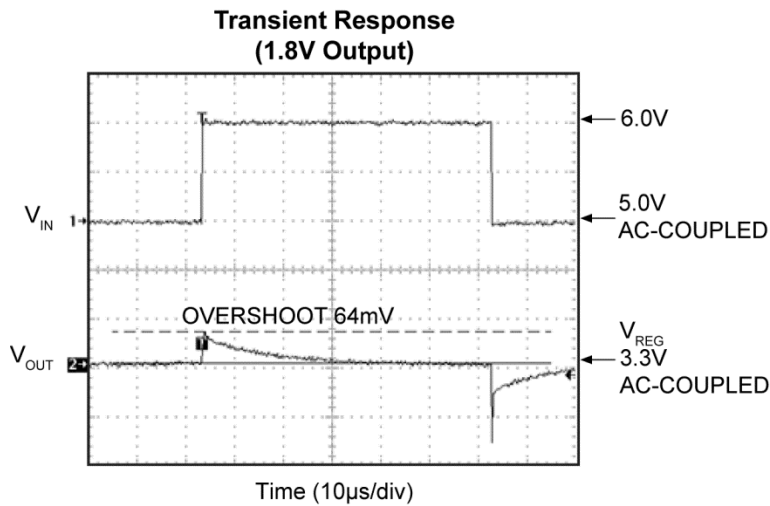
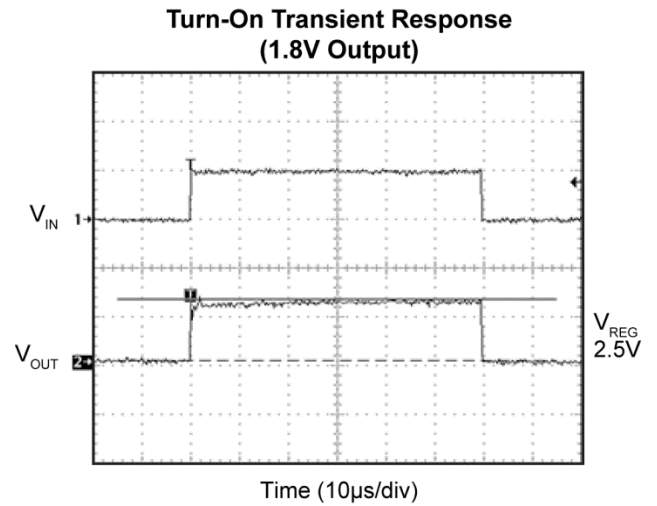
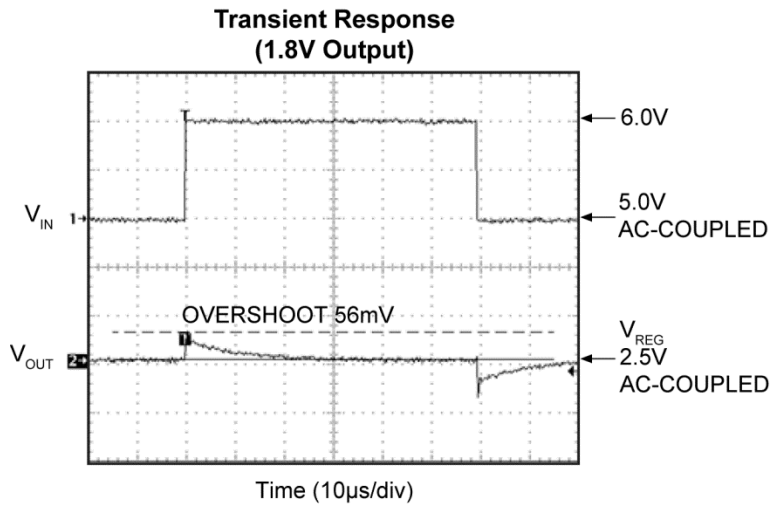
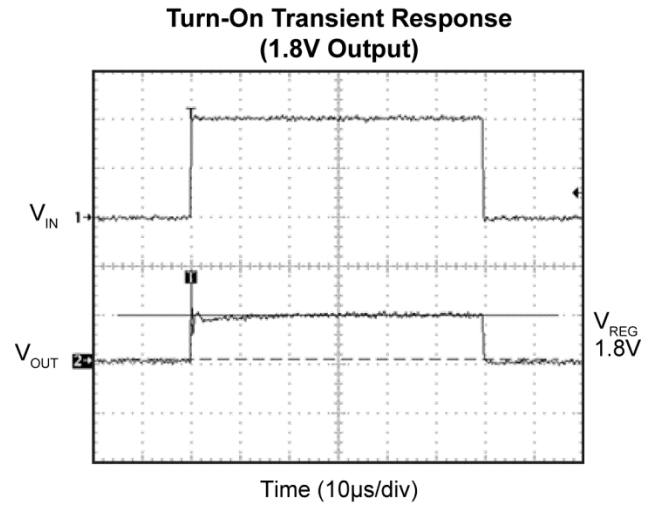
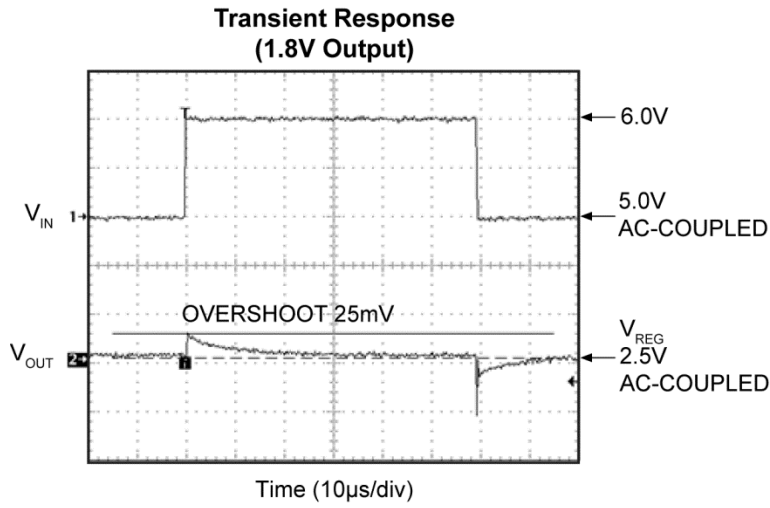

### Functional Diagram

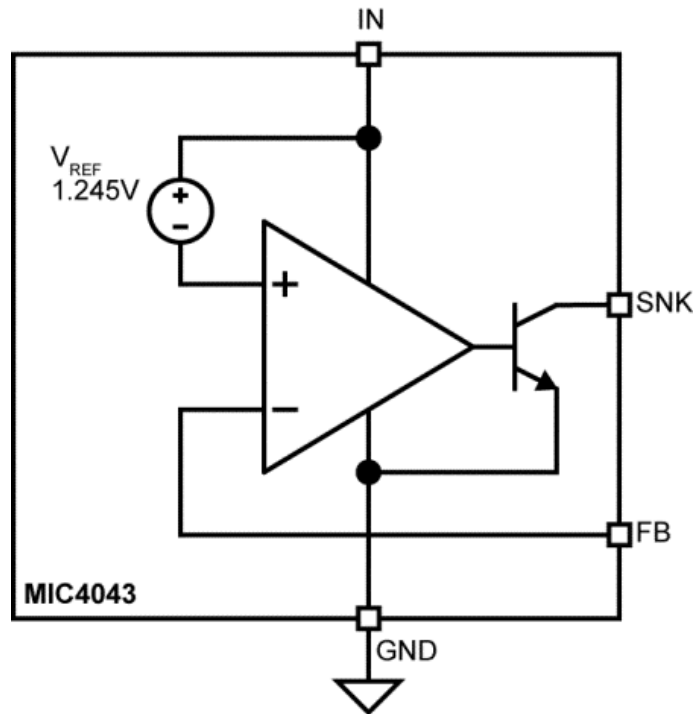

## Functional Description

The MIC4043 combines a  $G_M$  amplifier, precision 1.245V reference, and a pass transistor in a single package.

The operation of the MIC4043 is similar to conventional shunt regulators such as the industry standard '431. In a closed loop system, the MIC4043 maintains the desired feedback voltage at the FB pin by sinking current onto the SNK pin proportional to the error voltage at the FB pin. The ratio of sink current to error voltage is the transconductance of the device.

### Reference

The MIC4043 uses a high-side reference. External voltage dividers providing feedback to the MIC4043 will be inverted when compared to those used with '431-equivalent devices.

### Behavior

The external feedback voltage is compared to the internal high-side 1.245V reference.

If the feedback voltage,  $V_{FB}$ , is less than  $V_{IN} - V_{REF}$ , the amplifier provides no drive to the sink transistor. If the feedback voltages are greater than  $V_{IN} - V_{REF}$ , the amplifier drives the pass transistor which sinks current to ground.



## Application Information

### Replacement of '431-Type Devices

Since the MIC4043 uses a high-side reference, external voltage dividers providing the feedback voltage will be inverted when compared to those used with '431-equivalent devices.

The industry-standard '431 is also typically used in series with an opto-isolator LED. This configuration has a voltage drop of at least 2.5V for the '431 plus 1.4V for the LED (3.9V). More recent lower-voltage shunt regulators require at least 1.25V of headroom in addition to the 1.4V for the opto-isolator, for a total of 2.65V.

The MIC4043 removes the need to place the shunt reference in parallel with the opto-isolator. The MIC4043 combines a 1.245V reference in conjunction with an error amplifier that drives an NPN output transistor. The NPN transistor is connected in series with the opto-isolator and regulates the drive current in the opto-isolator. Unlike conventional shunt regulators, the MIC4043 does not have to connect the shunt reference in series with the opto-isolator, so the voltage drop is just the saturation voltage for one transistor, typically 160mV at full load.

### Compensation

The non-inverting side of the error amplifier is connected to the high-side reference; the reference is connected to the IN pin. The inverting side of the error amplifier is brought out to the FB pin. For some applications, no compensation is needed, but for most, some resistor capacitor network is necessary between the FB pin and GND pin. The value of the feedback capacitance is application specific, but for most applications 100pF to 3000pF is all that is needed. Changing the feedback capacitor changes the loop response; that is, phase and gain margin. An empirical way to check overall system loop response, if a network analyzer is not available, is to step load the output of the systems from 10% to 100% of nominal load. The resultant small signal response at the output of the systems will provide an idea of which direction to go based on the overshoot and settling time of  $V_{OUT}$ .

### Voltage Detector

Figure 1 shows a simple voltage threshold detector with a logic output.

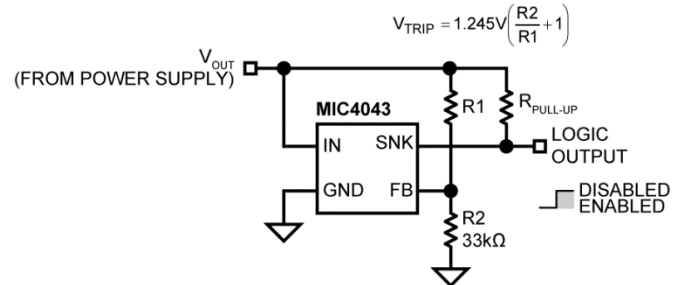

Figure 1. Voltage Detector

### High-Current Regulator

For the high-current regulator shown in Figure 2, headroom is equal to the saturation voltage of Q1 plus the saturation voltage of the MIC4043 ( $V_{SAT(MIN)} = 200mV$ ).

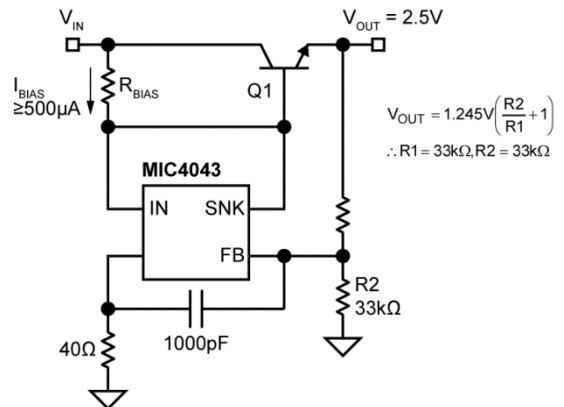

Figure 2. High-Current Regulator

### Off-Line 1.8V/2A Power Supply

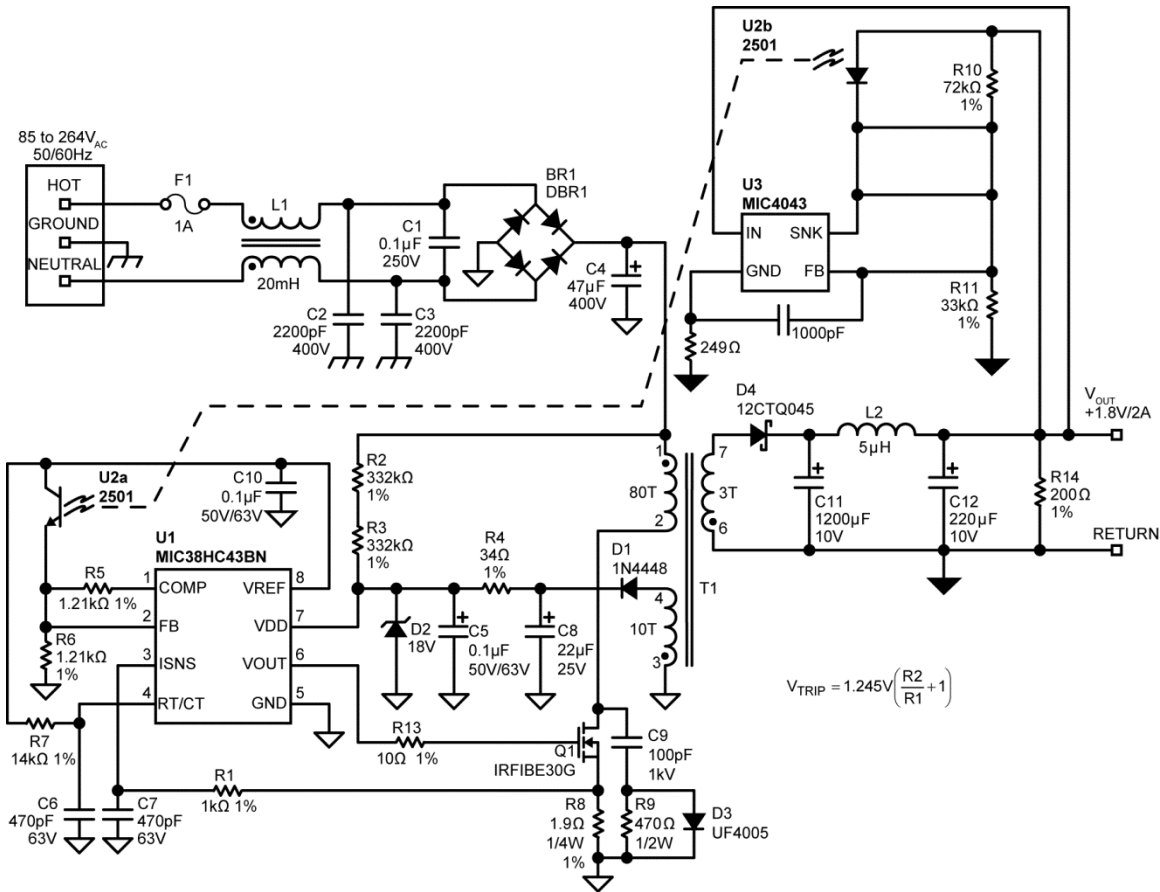

Figure 3. Off-Line 1V/2A Power Supply

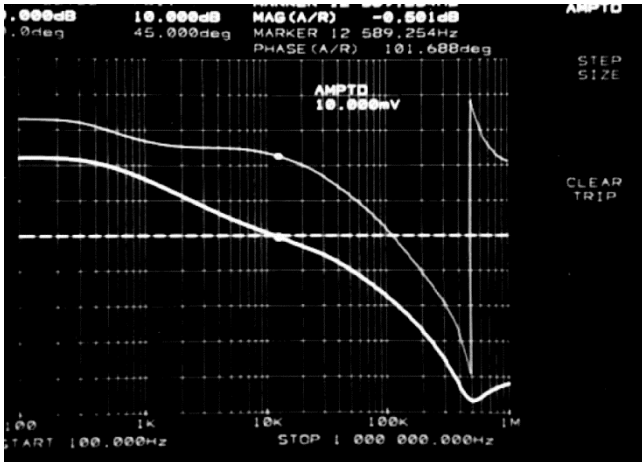

Figure 4. 1.8V/1A Output Bode Plot  
(θ Margin = 102°)

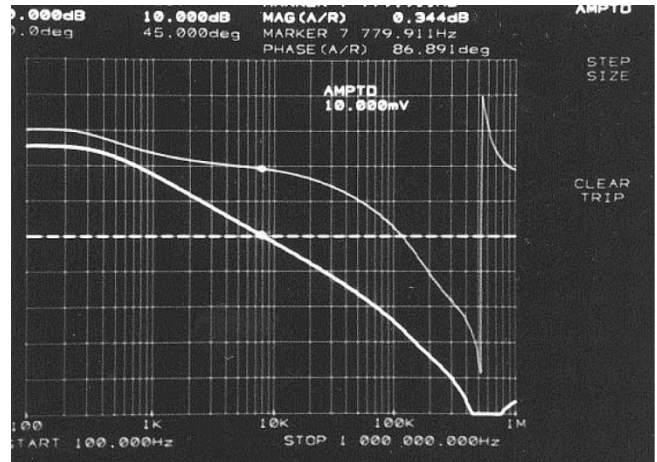

Figure 5. 1.8V/2A Output Bode Plot  
(θ Margin = 87°)

### Off-Line 2.5V/2A Power Supply

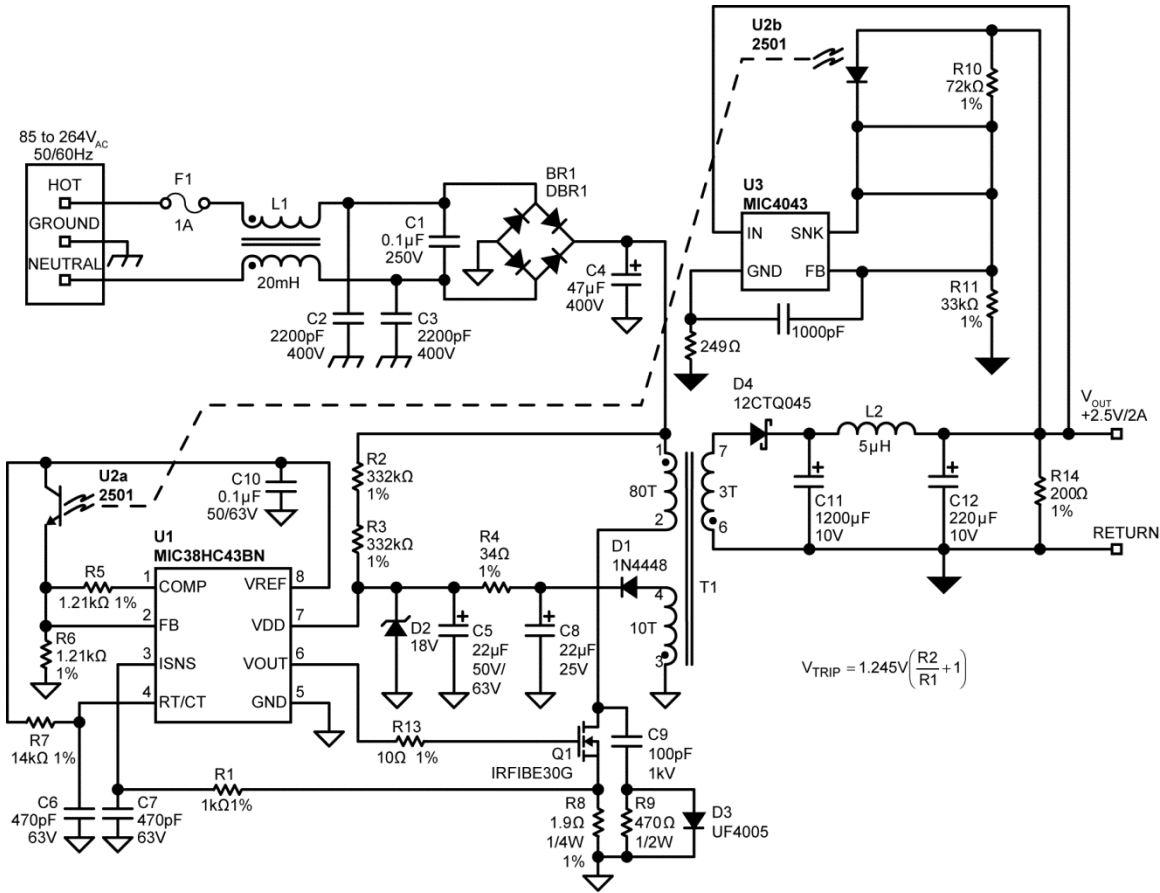

Figure 6. Off-Line 2.5V/2A Power Supply

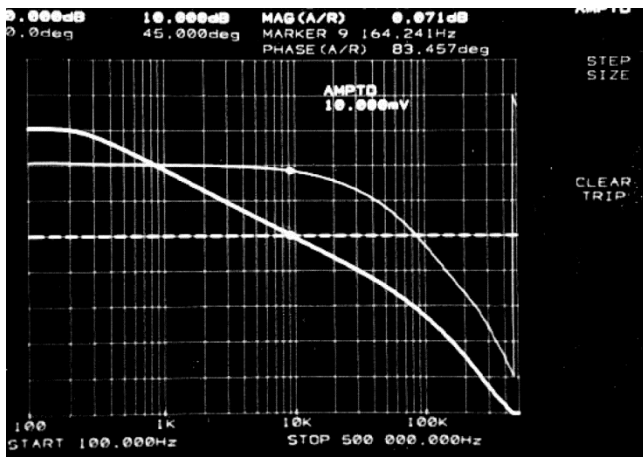

Figure 7. 2.5V/1A Output Bode Plot  
(θ Margin = 83°)

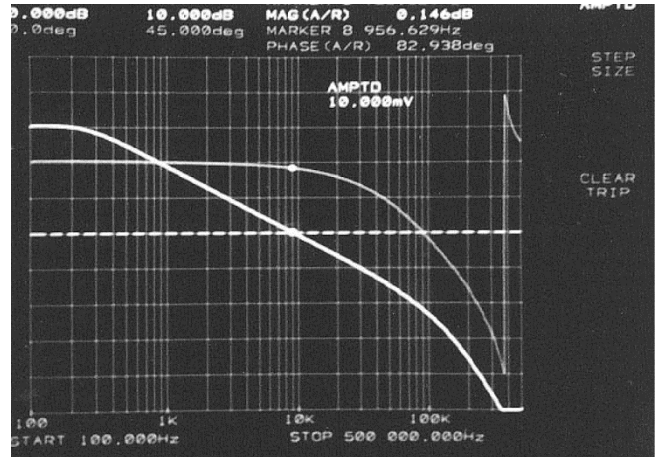

Figure 8. 2.5V/2A Output Bode Plot  
(θ Margin = 83°)

Off-Line 3.3V/2A Power Supply

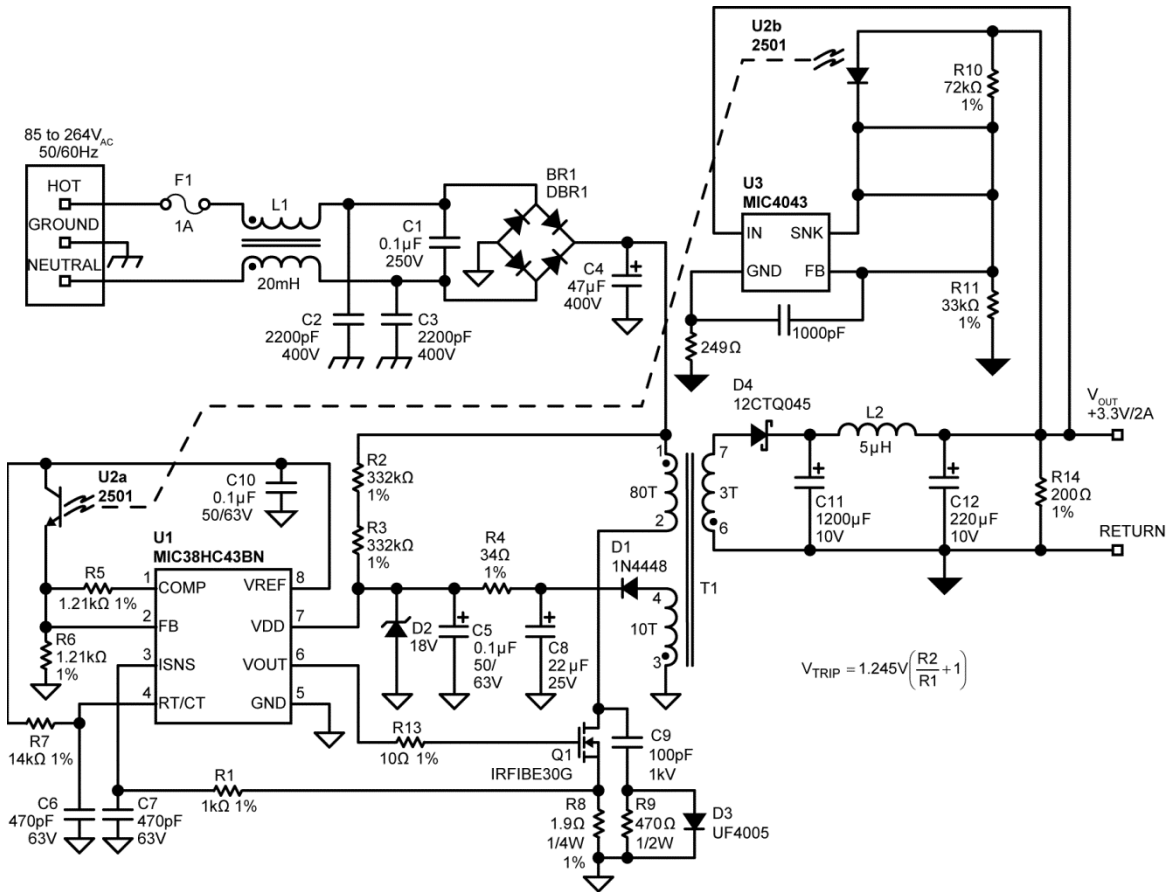

Figure 9. Off-Line 3.3V/2A Power Supply

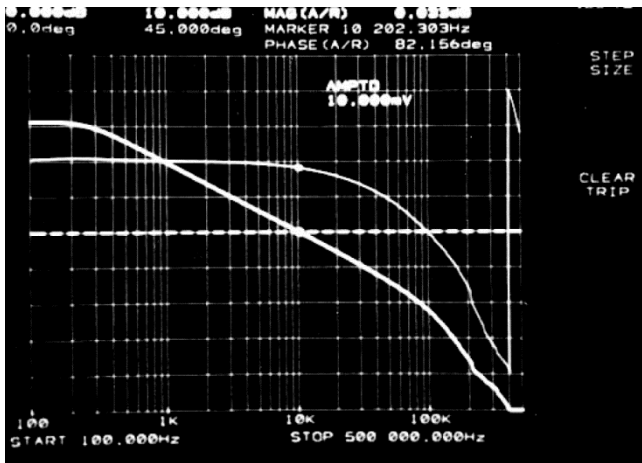

Figure 10. 3.3V/1A Output Bode Plot  
(θ Margin = 82°)

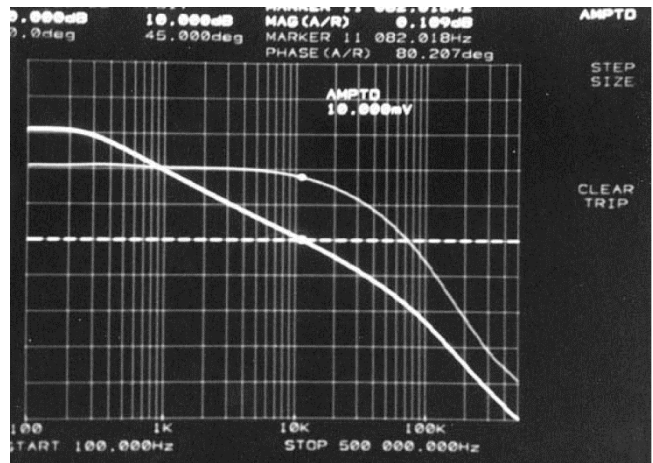

Figure 11. 3.3V/2A Output Bode Plot  
(θ Margin = 80°)

Off-Line 5V/2A Power Supply

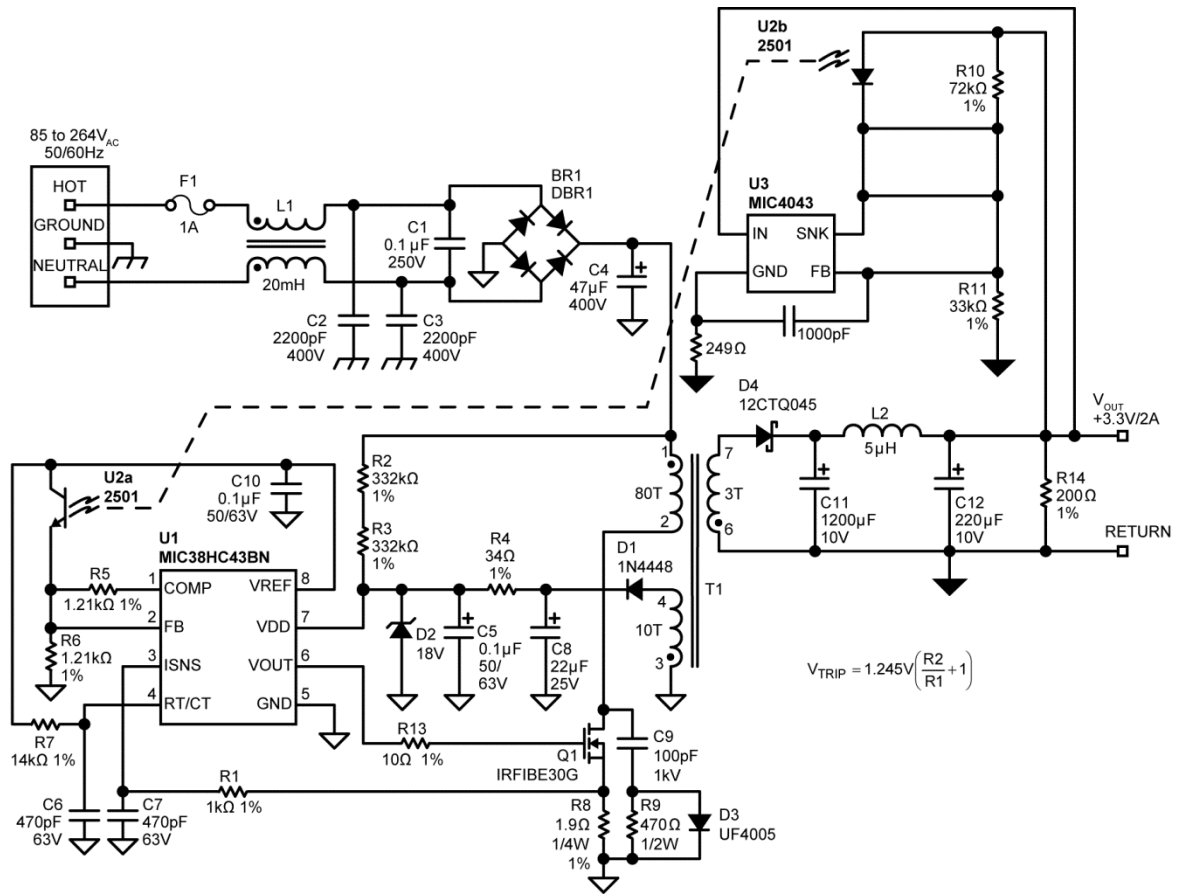

Figure 12. Off-Line 5V/2A Power Supply

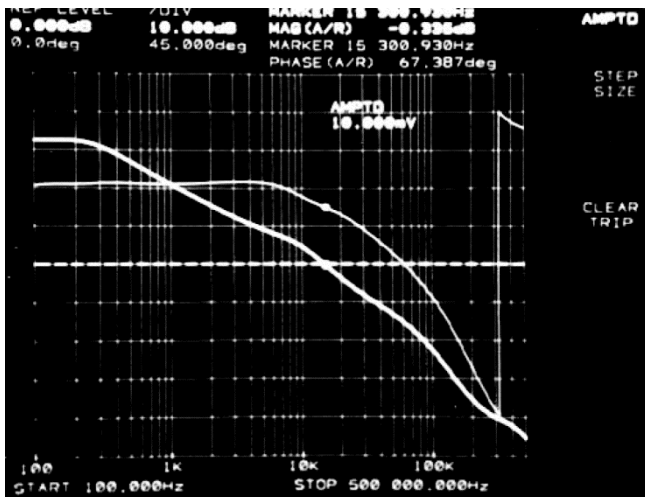

Figure 13. 5V/1A Output Bode Plot (θ Margin = 67°)

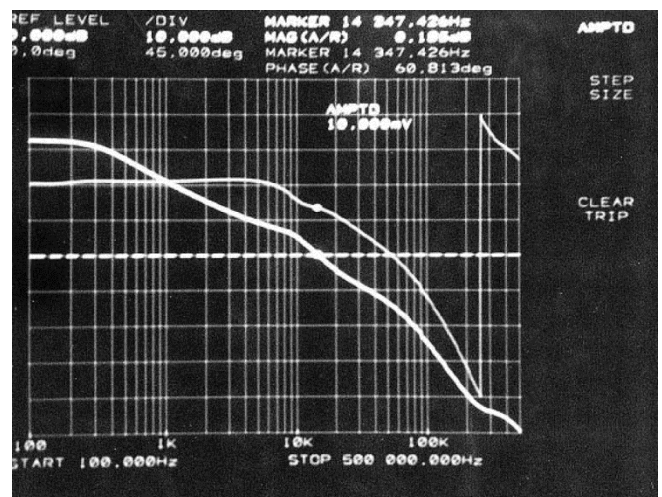
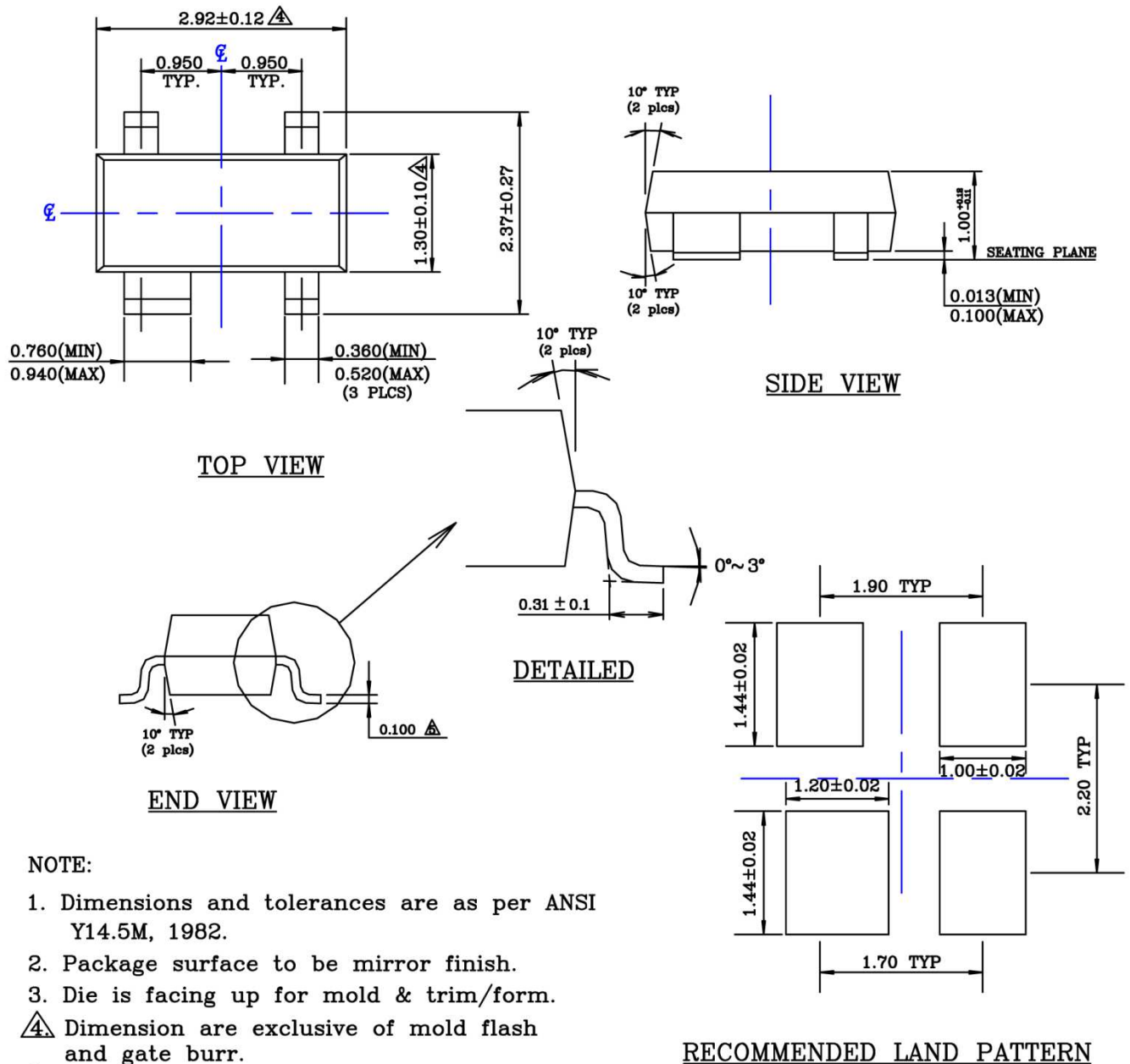

Figure 14. 5V/2A Output Bode Plot (θ Margin = 61°)

Package Information and Recommended Landing Pattern<sup>(6)</sup>



NOTE:

1. Dimensions and tolerances are as per ANSI Y14.5M, 1982.
2. Package surface to be mirror finish.
3. Die is facing up for mold & trim/form.
- ④ Dimension are exclusive of mold flash and gate burr.
- ⑤ Dimension are exclusive of solder plating.

SOT-143 (M4)

Note:

6. Package information is correct as of the publication date. For updates and most current information, go to [www.micrel.com](http://www.micrel.com).

---

**MICREL, INC. 2180 FORTUNE DRIVE SAN JOSE, CA 95131 USA**  
TEL +1 (408) 944-0800 FAX +1 (408) 474-1000 WEB <http://www.micrel.com>

Micrel, Inc. is a leading global manufacturer of IC solutions for the worldwide high performance linear and power, LAN, and timing & communications markets. The Company's products include advanced mixed-signal, analog & power semiconductors; high-performance communication, clock management, MEMs-based clock oscillators & crystal-less clock generators, Ethernet switches, and physical layer transceiver ICs. Company customers include leading manufacturers of enterprise, consumer, industrial, mobile, telecommunications, automotive, and computer products. Corporation headquarters and state-of-the-art wafer fabrication facilities are located in San Jose, CA, with regional sales and support offices and advanced technology design centers situated throughout the Americas, Europe, and Asia. Additionally, the Company maintains an extensive network of distributors and reps worldwide.

Micrel makes no representations or warranties with respect to the accuracy or completeness of the information furnished in this datasheet. This information is not intended as a warranty and Micrel does not assume responsibility for its use. Micrel reserves the right to change circuitry, specifications and descriptions at any time without notice. No license, whether express, implied, arising by estoppel or otherwise, to any intellectual property rights is granted by this document. Except as provided in Micrel's terms and conditions of sale for such products, Micrel assumes no liability whatsoever, and Micrel disclaims any express or implied warranty relating to the sale and/or use of Micrel products including liability or warranties relating to fitness for a particular purpose, merchantability, or infringement of any patent, copyright, or other intellectual property right.

Micrel Products are not designed or authorized for use as components in life support appliances, devices or systems where malfunction of a product can reasonably be expected to result in personal injury. Life support devices or systems are devices or systems that (a) are intended for surgical implant into the body or (b) support or sustain life, and whose failure to perform can be reasonably expected to result in a significant injury to the user. A Purchaser's use or sale of Micrel Products for use in life support appliances, devices or systems is a Purchaser's own risk and Purchaser agrees to fully indemnify Micrel for any damages resulting from such use or sale.

© 2000 Micrel, Incorporated.