



Chipsmall Limited consists of a professional team with an average of over 10 year of expertise in the distribution of electronic components. Based in Hongkong, we have already established firm and mutual-benefit business relationships with customers from,Europe,America and south Asia,supplying obsolete and hard-to-find components to meet their specific needs.

With the principle of "Quality Parts,Customers Priority,Honest Operation,and Considerate Service",our business mainly focus on the distribution of electronic components. Line cards we deal with include Microchip,ALPS,ROHM,Xilinx,Pulse,ON,Everlight and Freescale. Main products comprise IC,Modules,Potentiometer,IC Socket,Relay,Connector.Our parts cover such applications as commercial,industrial, and automotives areas.

We are looking forward to setting up business relationship with you and hope to provide you with the best service and solution. Let us make a better world for our industry!



Contact us

Tel: +86-755-8981 8866 Fax: +86-755-8427 6832

Email & Skype: info@chipsmall.com Web: www.chipsmall.com

Address: A1208, Overseas Decoration Building, #122 Zhenhua RD., Futian, Shenzhen, China



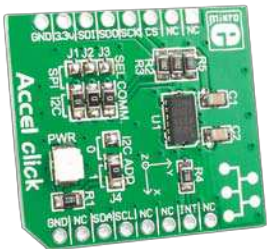

Accel click™

1. Introduction

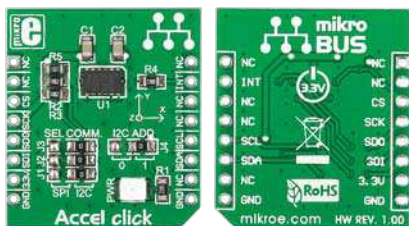

Accel Click™ is an accessory board in **mikroBUS™** form factor. It's a compact and easy solution for adding accelerometer functionality to your device. It features **ADXL345** 3-axis accelerometer module with ultra-low power and high resolution (13-bit) measurement. Accel Click™ communicates with target board via I²C or SPI interface. The Board is designed to use 3.3V power supply only. It has a LED diode (GREEN) which indicates the presence of power supply.

2. Soldering the headers

Before using your click board™, make sure to solder 1x8 male headers to both left and right side of the board. Two 1x8 male headers are included with the board in the package.



1

2

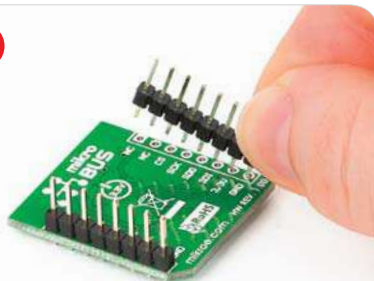

Turn the board upside down so that bottom side is facing you upwards. Place shorter parts of the header pins in both soldering pad locations.

3

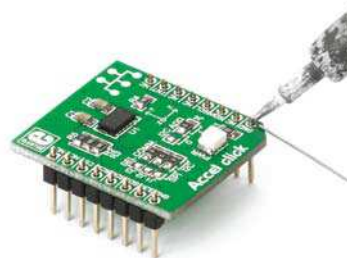

Turn the board upward again. Make sure to align the headers so that they are perpendicular to the board, then solder the pins carefully.

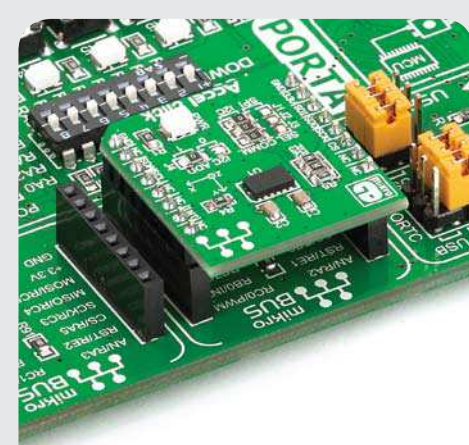

4. Essential features

Accel Click™ with its **ADXL345** module supports several sensing functions such as single/double tap detection, activity/inactivity monitoring, free-fall detection etc. It has memory management system with a 32-level FIFO buffer to store data with minimized host processor activity. All these features make this board ideal for mobile devices, medical and industrial instrumentation, navigation devices, hard drive protection and more.

3. Plugging the board in

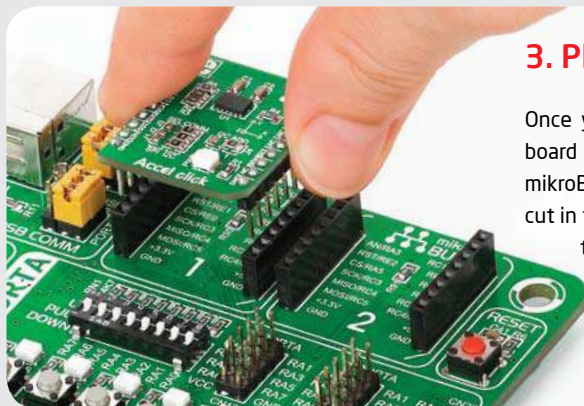

Once you have soldered the headers your board is ready to be placed into desired mikroBUS™ socket. Make sure to align the cut in the lower-right part of the board with the markings on the silkscreen at the mikroBUS™ socket. If all of the pins are aligned correctly, push the board all the way into the socket.

click™
BOARD
www.mikroe.com



Accel click Manual
ver. 1.00



5. Accel Click™ Board Schematic

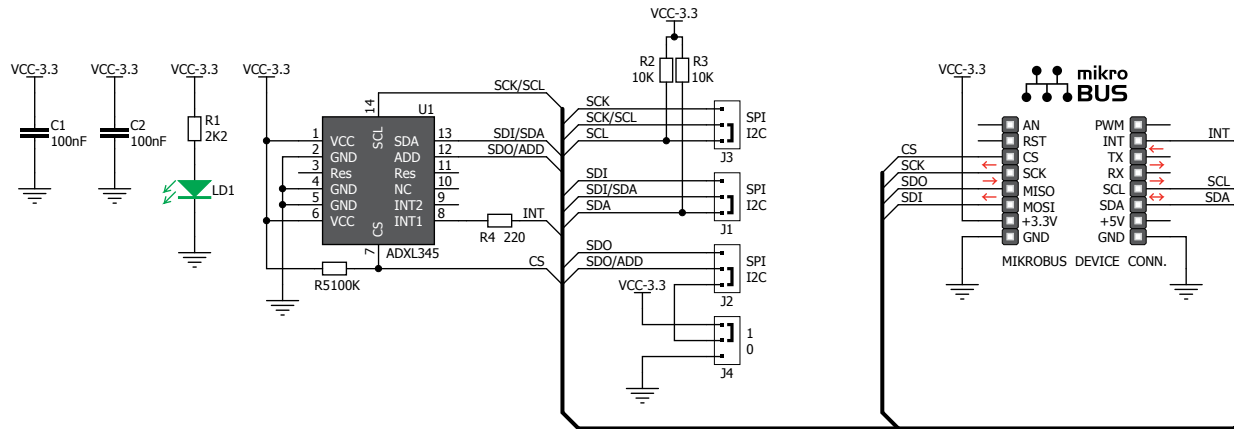

6. SMD Jumpers

The Accel Click™ board communicates with the main board via I²C or SPI interface depending on the position of the **J1**, **J2** and **J3** SMD jumpers. These jumpers are soldered in I²C interface position by default. There is an option to select the alternate address with jumper **J4** in the case of I²C interface (default position is logic 1).

7. Code Examples

Once you have done all the necessary preparations, it's time to get your click board™ up and running. We have provided the examples for mikroC, mikroBasic and mikroPascal compilers on our **Libstock** website. Just download them and you are ready to start.



8. Support

MikroElektronika offers **Free Tech Support** (www.mikroe.com/esupport) until the end of product lifetime, so if something goes wrong, we are ready and willing to help!