



Chipsmall Limited consists of a professional team with an average of over 10 year of expertise in the distribution of electronic components. Based in Hongkong, we have already established firm and mutual-benefit business relationships with customers from,Europe,America and south Asia,supplying obsolete and hard-to-find components to meet their specific needs.

With the principle of "Quality Parts,Customers Priority,Honest Operation,and Considerate Service",our business mainly focus on the distribution of electronic components. Line cards we deal with include Microchip,ALPS,ROHM,Xilinx,Pulse,ON,Everlight and Freescale. Main products comprise IC,Modules,Potentiometer,IC Socket,Relay,Connector.Our parts cover such applications as commercial,industrial, and automotives areas.

We are looking forward to setting up business relationship with you and hope to provide you with the best service and solution. Let us make a better world for our industry!



Contact us

Tel: +86-755-8981 8866 Fax: +86-755-8427 6832

Email & Skype: info@chipsmall.com Web: www.chipsmall.com

Address: A1208, Overseas Decoration Building, #122 Zhenhua RD., Futian, Shenzhen, China



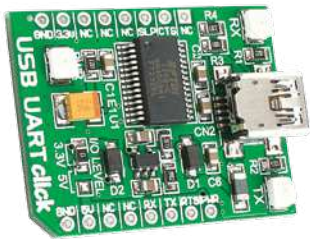

USB UART click™

1. Introduction

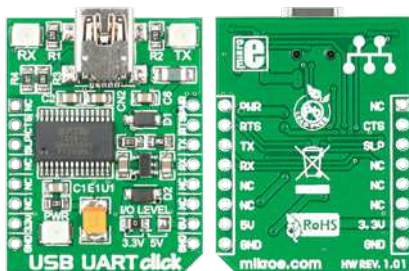

USB UART Click™ is an accessory board in mikroBUS™ form factor. It's a compact and easy solution for adding serial UART communication via USB cable. It features FT232RL USB-to-UART interface module as well as USB MINI B connector. USB UART Click™ communicates with target board via UART interface. The board is designed to use 3.3V or 5V I/O level. It has a LED diode (GREEN) that indicates the presence of power supply.

2. Soldering the headers

Before using your click board™, make sure to solder 1x8 male headers to both left and right side of the board. Two 1x8 male headers are included with the board in the package.



1

2

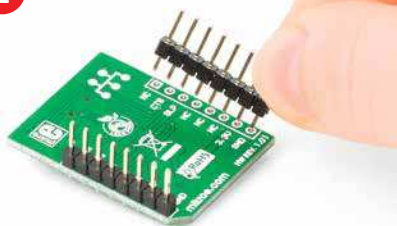

Turn the board upside down so that bottom side is facing you upwards. Place shorter parts of the header pins in both soldering pad locations.

3



Turn the board upward again. Make sure to align the headers so that they are perpendicular to the board, then solder the pins carefully.

3. Plugging the board in

Once you have soldered the headers your board is ready to be placed into desired mikroBUS™ socket. Make sure to align the cut in the lower-right part of the board with the markings on the silkscreen at the mikroBUS™ socket. If all of the pins are aligned correctly, push the board all the way into the socket.

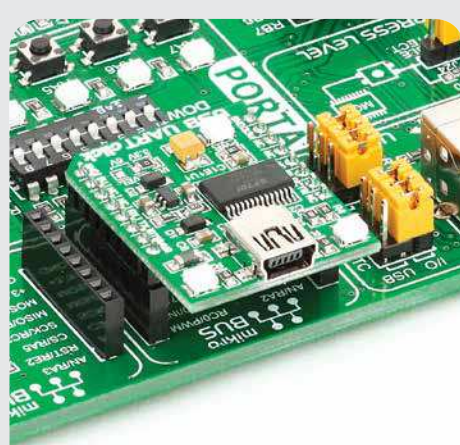

4. Essential features

USB UART Click™ with its FT232RL IC gives additional serial UART communication via USB cable. The FT232RL contains integrated 1024 bit EEPROM, 128 bytes long receive buffer, 256 bytes long transmit buffer, configurable CBUS I/O pins and entire USB protocol handled on the chip. The board contains RX and TX LED diodes that indicate the transmit and receive data via USB.

click™
BOARD
www.mikroe.com



USB UART click Manual
ver. 1.01



0 100000 021231

5. USB UART Click™ Board Schematic

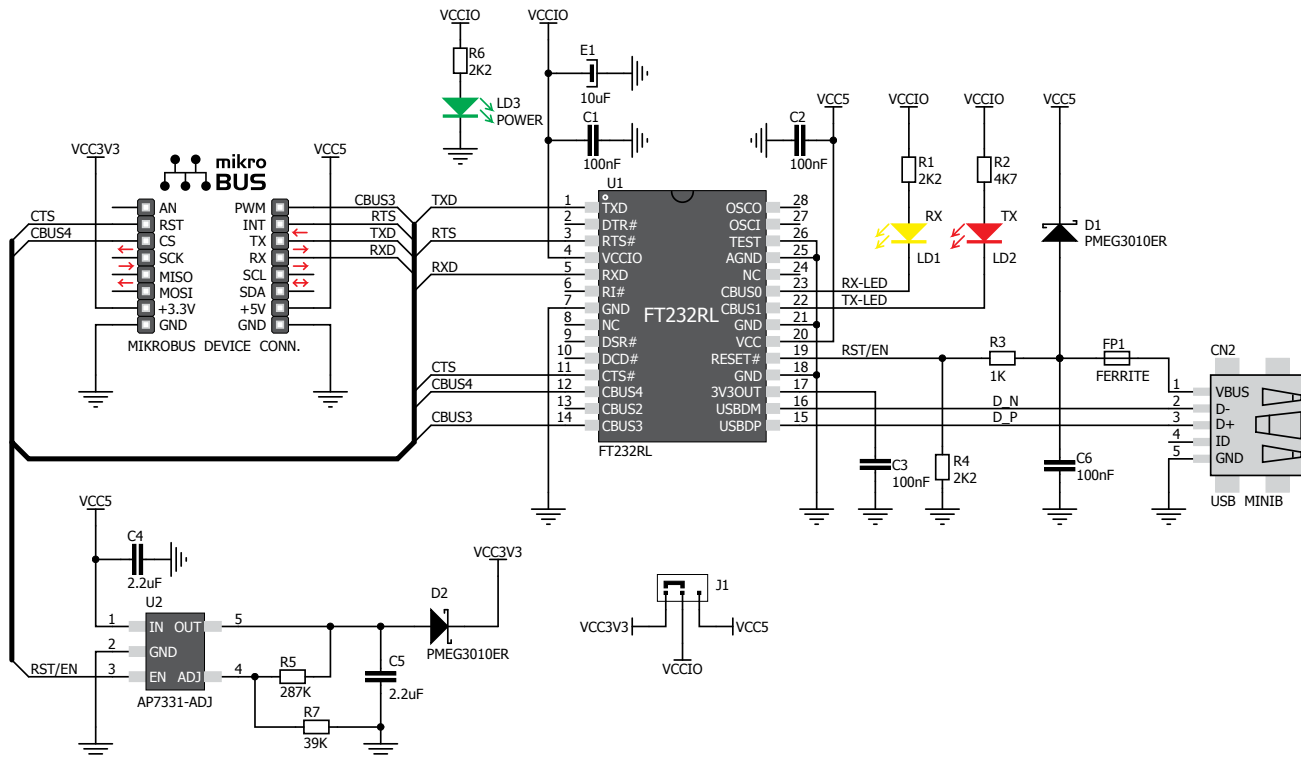

6. SMD Jumper



There is one zero-ohm SMD jumper **J1** which is used to select whether 3.3V or 5V I/O level is used. Jumper **J1** is soldered in 3.3V position by default.

7. Code Examples

Once you have done all the necessary preparations, it's time to get your click board up and running. We have provided the examples for mikroC, mikroBasic and mikroPascal compilers on our **Libstock** website. Just download them and you are ready to start.



8. Support

MikroElektronika offers **Free Tech Support** (www.mikroe.com/esupport) until the end of product lifetime, so if something goes wrong, we are ready and willing to help!