



Chipsmall Limited consists of a professional team with an average of over 10 year of expertise in the distribution of electronic components. Based in Hongkong, we have already established firm and mutual-benefit business relationships with customers from,Europe,America and south Asia,supplying obsolete and hard-to-find components to meet their specific needs.

With the principle of "Quality Parts,Customers Priority,Honest Operation,and Considerate Service",our business mainly focus on the distribution of electronic components. Line cards we deal with include Microchip,ALPS,ROHM,Xilinx,Pulse,ON,Everlight and Freescale. Main products comprise IC,Modules,Potentiometer,IC Socket,Relay,Connector.Our parts cover such applications as commercial,industrial, and automotives areas.

We are looking forward to setting up business relationship with you and hope to provide you with the best service and solution. Let us make a better world for our industry!



Contact us

Tel: +86-755-8981 8866 Fax: +86-755-8427 6832

Email & Skype: info@chipsmall.com Web: www.chipsmall.com

Address: A1208, Overseas Decoration Building, #122 Zhenhua RD., Futian, Shenzhen, China





4-20mA T click™

1. Introduction

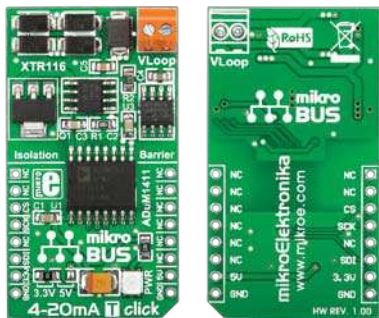

4-20mA T Click™ is an accessory board in **mikroBUS™** form factor. It's a compact and easy solution for adding 4-to-20mA industry standard communication protocol to your design. It features **ADuM1411** Quad-channel digital isolator, **MCP4921** 12-bit DAC as well as **XTR116** 4-20mA current loop transmitter. 4-20mA T Click™ communicates with target board microcontroller via three **mikroBUS™** SPI lines (SDI, SCK, CS). The board is designed to use 3.3V and 5V power supply. LED diode indicates the presence of power supply.

2. Soldering the headers

Before using your click board™, make sure to solder 1x8 male headers to both left and right side of the board. Two 1x8 male headers are included with the board in the package.



1

2

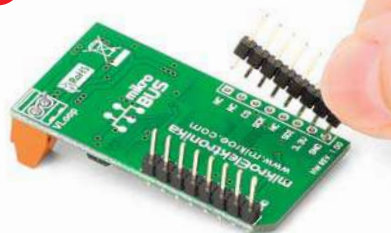

Turn the board upside down so that bottom side is facing you upwards. Place shorter parts of the header pins in both soldering pad locations.

3



Turn the board upward again. Make sure to align the headers so that they are perpendicular to the board, then solder the pins carefully.

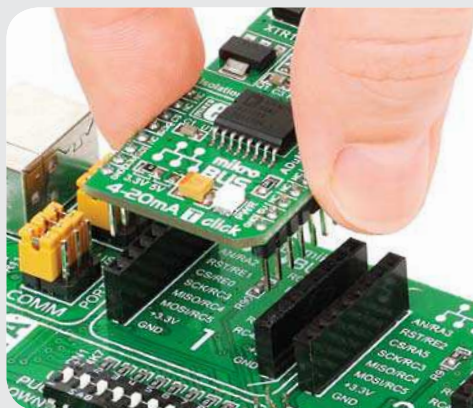

3. Plugging the board in

Once you have soldered the headers your board is ready to be placed into desired mikroBUS™ socket. Make sure to align the cut in the lower-right part of the board with the markings on the silkscreen at the mikroBUS™ socket. If all of the pins are aligned correctly, push the board all the way into the socket.

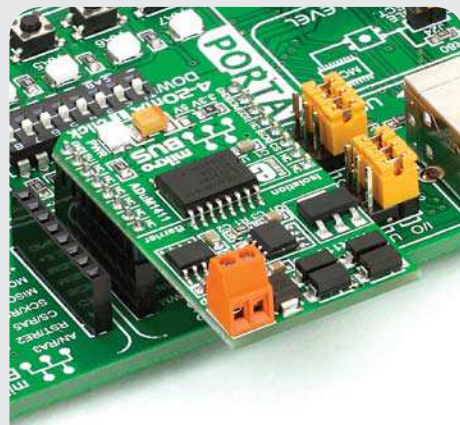

4. Essential features

4-20mA T Click™ with its **ADuM1411**, **MCP4921** and **XTR116** IC's is ideal for using in field of industrial process control and test systems. It serves as interface between sensors or instruments (connected to microcontroller) and controlled peripherals in industrial standard current loop. The board receives the input digital signal from the microcontroller and sets the output loop current (4-20mA).

click™
BOARD
www.mikroe.com



4-20mA T click Manual
ver. 1.00



5. 4-20mA T Click™ Board Schematic

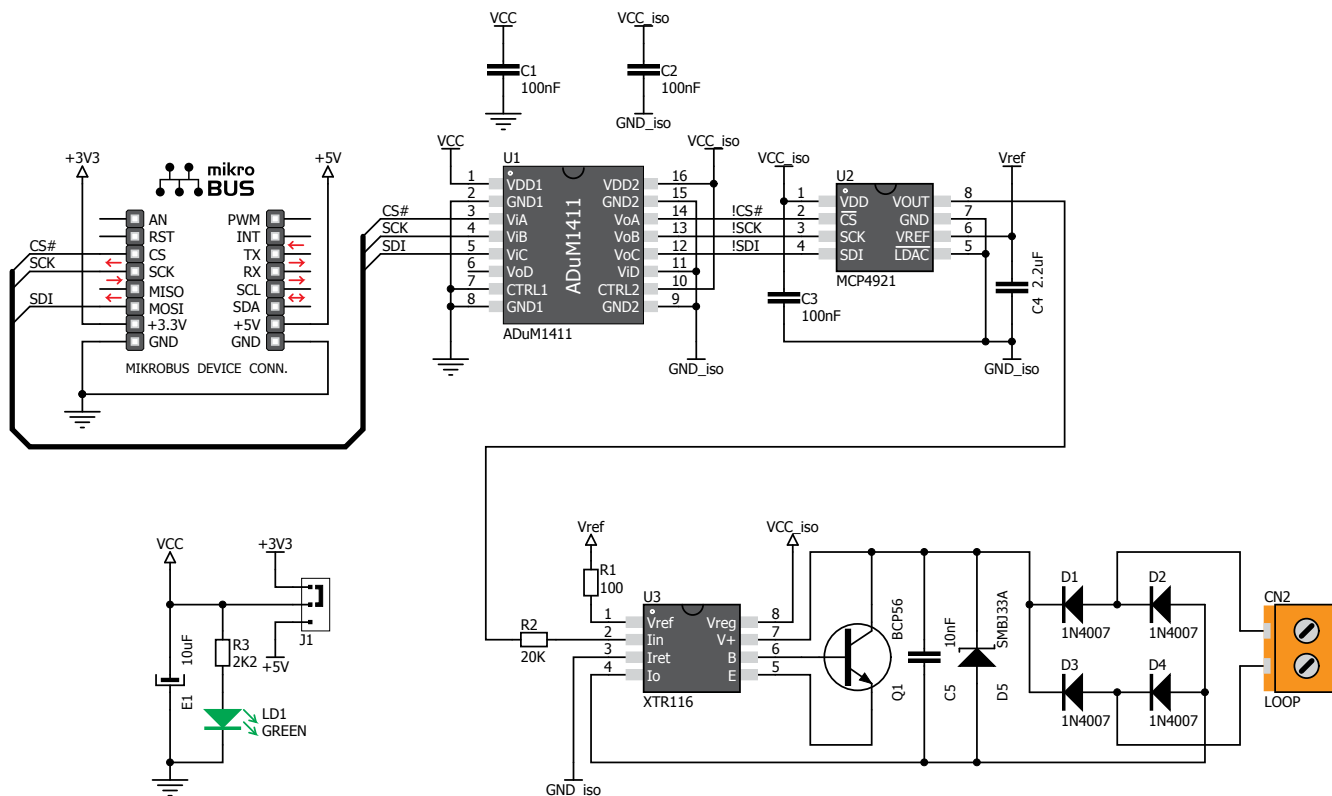

6. SMD Jumper



There is one zero-ohm SMD jumper **J1** which is used to select whether 3.3V or 5V power supply is used. Jumper **J1** is soldered in 3.3V position by default.

7. Code Examples

Once you have done all the necessary preparations, it's time to get your click board up and running. We have provided the examples for mikroC, mikroBasic and mikroPascal compilers on our **Libstock** website. Just download them and you are ready to start.



8. Support

MikroElektronika offers **Free Tech Support** (www.mikroe.com/esupport) until the end of product lifetime, so if something goes wrong, we are ready and willing to help!