



Chipsmall Limited consists of a professional team with an average of over 10 year of expertise in the distribution of electronic components. Based in Hongkong, we have already established firm and mutual-benefit business relationships with customers from,Europe,America and south Asia,supplying obsolete and hard-to-find components to meet their specific needs.

With the principle of “Quality Parts,Customers Priority,Honest Operation,and Considerate Service”,our business mainly focus on the distribution of electronic components. Line cards we deal with include Microchip,ALPS,ROHM,Xilinx,Pulse,ON,Everlight and Freescale. Main products comprise IC,Modules,Potentiometer,IC Socket,Relay,Connector.Our parts cover such applications as commercial,industrial, and automotives areas.

We are looking forward to setting up business relationship with you and hope to provide you with the best service and solution. Let us make a better world for our industry!



Contact us

Tel: +86-755-8981 8866 Fax: +86-755-8427 6832

Email & Skype: info@chipsmall.com Web: www.chipsmall.com

Address: A1208, Overseas Decoration Building, #122 Zhenhua RD., Futian, Shenzhen, China



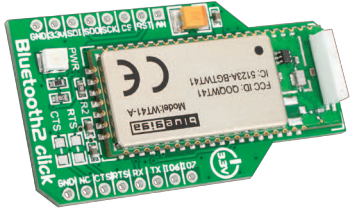

Bluetooth2 click™

1. Introduction

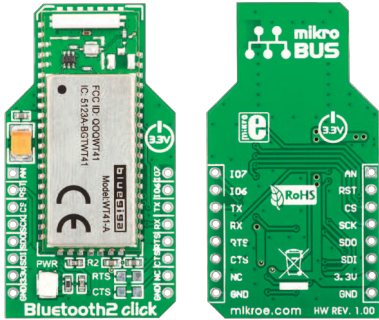

Bluetooth2 Click™ is an accessory board in **mikroBUS™** form factor. It's a compact and easy solution for adding bluetooth module to your design. It features BLUEGIGA **WT41** Bluetooth® 2.1 with EDR module. Bluetooth2 Click™ communicates with the target board microcontroller via **mikroBUS™** UART (Tx, Rx), SPI (MOSI, MISO, SCK, CS), SDA, SCL, RST, AN, INT and PWM lines. The board is designed to use 3.3V power supply only. LED diode (GREEN) indicates the presence of power supply.

2. Soldering the headers

Before using your click board™, make sure to solder 1x8 male headers to both left and right side of the board. Two 1x8 male headers are included with the board in the package.



1

2

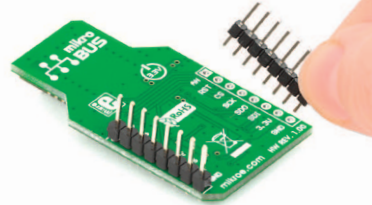

Turn the board upside down so that bottom side is facing you upwards. Place shorter parts of the header pins in both soldering pad locations.

3



Turn the board upward again. Make sure to align the headers so that they are perpendicular to the board, then solder the pins carefully.

3. Plugging the board in

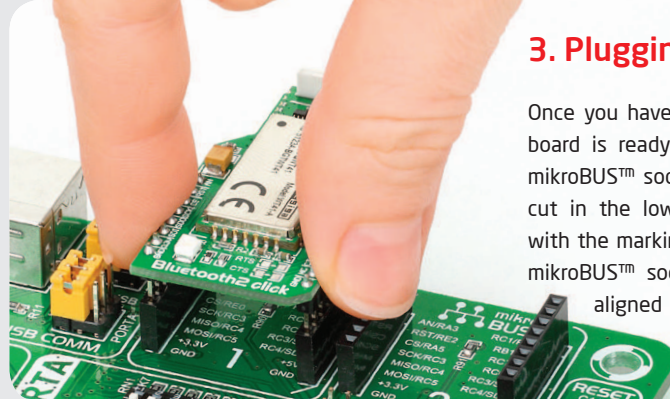

Once you have soldered the headers your board is ready to be placed into desired mikroBUS™ socket. Make sure to align the cut in the lower-right part of the board with the markings on the silkscreen at the mikroBUS™ socket. If all of the pins are aligned correctly, push the board all the way into the socket.

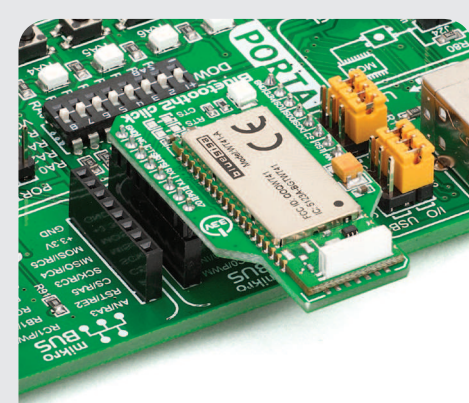

4. Essential features

Bluetooth2 Click™ with its **WT41** contains all the necessary elements from Bluetooth® radio to antenna and fully implemented protocol stack. It is equipped with iWRAP firmware which enables users to access Bluetooth® functionality with simple ASCII commands delivered to the module. It is ideal for developers who want to integrate Bluetooth® wireless protocol with limited knowledge of Bluetooth® and RF technologies. The board is optimized for long range applications.

click™
BOARD
www.mikroe.com

Bluetooth2 click Manual
ver. 1.00



5. Bluetooth2 Click™ Board Schematic

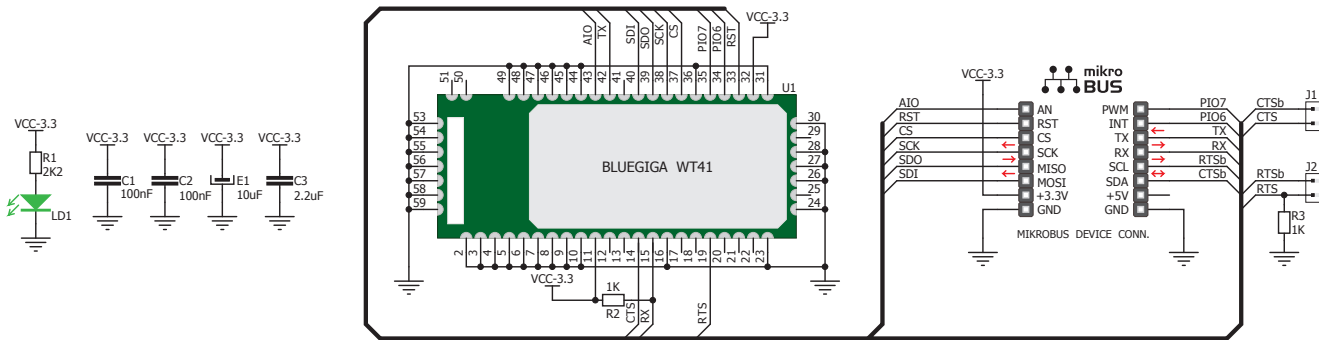

6. SMD jumpers

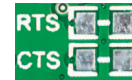

The Bluetooth2 Click™ board uses four UART interface lines. Two of them are for data transfer between WT41 module and main board microcontroller (Tx and Rx) and other two are for hardware flow control (CTS and RTS). If you want to use CTS and RTS lines, solder two zero-ohm SMD jumpers **J1** and **J2**. They are not soldered by default.

7. Code Examples

Once you have done all the necessary preparations, it's time to get your click board up and running. We have provided the examples for mikroC, mikroBasic and mikroPascal compilers on our **Libstock** website. Just download them and you are ready to start.



8. Support

MikroElektronika offers **Free Tech Support** (www.mikroe.com/esupport) until the end of product lifetime, so if something goes wrong, we are ready and willing to help!

