



Chipsmall Limited consists of a professional team with an average of over 10 year of expertise in the distribution of electronic components. Based in Hongkong, we have already established firm and mutual-benefit business relationships with customers from,Europe,America and south Asia,supplying obsolete and hard-to-find components to meet their specific needs.

With the principle of “Quality Parts,Customers Priority,Honest Operation,and Considerate Service”,our business mainly focus on the distribution of electronic components. Line cards we deal with include Microchip,ALPS,ROHM,Xilinx,Pulse,ON,Everlight and Freescale. Main products comprise IC,Modules,Potentiometer,IC Socket,Relay,Connector.Our parts cover such applications as commercial,industrial, and automotives areas.

We are looking forward to setting up business relationship with you and hope to provide you with the best service and solution. Let us make a better world for our industry!



## Contact us

Tel: +86-755-8981 8866 Fax: +86-755-8427 6832

Email & Skype: info@chipsmall.com Web: www.chipsmall.com

Address: A1208, Overseas Decoration Building, #122 Zhenhua RD., Futian, Shenzhen, China





# mikromedia+

for Stellaris® ARM®

Amazingly compact, all-on-single-pcb development board carrying 4.3" TFT Touch Screen and lots of multimedia peripherals, all driven by powerful **LM4F232H5QD** microcontroller from ARM® Cortex™-M4 family



# TO OUR VALUED CUSTOMERS

I want to express my thanks to you for being interested in our products and for having confidence in MikroElektronika.

The primary aim of our company is to design and produce high quality electronic products and to constantly improve the performance thereof in order to better suit your needs.

A white handwritten signature in cursive script, appearing to read 'N. Matic', set against a dark green background.

Nebojsa Matic  
General Manager

# Table of Contents

Introduction to mikromedia+ for Stellaris® ARM®	4	4. RTC Battery and Reset Button	18
System Specification	4	5. Crystal oscillator and 2.048V reference	20
Package Contains	5	6. MicroSD Card Slot	22
1. Power supply	6	7. Touch Screen	24
2. LM4F232H5QD microcontroller	8	8. Audio Module	26
Key microcontroller features	8	9. USB DEVICE connection	28
3. Programming the microcontroller	9	10. USB HOST connection	30
Programming with mikroBootloader	10	11. Accelerometer	32
step 1 - Connecting mikromedia	10	12. Flash Memory	34
step 2 - Browsing for .HEX file	11	13. RF transceiver	36
step 3 - Selecting .HEX file	11	14. Buzzer	38
step 4 - Uploading .HEX file	12	15. Other modules	40
step 5 - Finish upload	13	16. Pads	42
Programming with mikroProg™ programmer	14	17. mikromedia+ accessories	44
mikroProg™ suite™ for ARM® software	16	18. What's next	46
Software installation wizard	17		

# Introduction to mikromedia+ for Stellaris® ARM®

The **mikromedia+ for Stellaris® ARM®** is a compact development system with lots of on-board peripherals which allow development of devices with multimedia contents. The central part of the system is a 32-bit **ARM® Cortex™-M4 LM4F232H5QD** 144-pin microcontroller. The mikromedia+ for Stellaris® ARM® features integrated modules such as stereo MP3 codec, **4.3" TFT 480x272** touch screen display, accelerometer, microSD card slot, buzzer, IR receiver, RGB LED diode, PIN photodiode, temperature sensor, 2.4GHz RF transceiver, 8 Mbit flash memory, RTC battery, Li-Polimer battery charger etc. The board also contains MINI-B USB connector, power screw terminals, 2x5 JTAG connector, two 1x26 connection pads, ON/OFF switch and other. It comes pre-programmed with USB HID bootloader, but can also be programmed with external programmers, such as **mikroProg™ for Stellaris®** or other JTAG programmers. Mikromedia is compact and slim, and perfectly fits in the palm of your hand, which makes it a convenient platform for mobile and other multimedia devices. We have also prepared a **mikromedia+ SHIELD for Stellaris® ARM®** extension board which enables you to easily expand the functionality of your board.

## System Specification



### power supply

Via USB cable (5V DC) or via screw terminals (2.5-12V DC)



### power consumption

26 mA with erased MCU  
(when on-board modules are inactive)



### board dimensions

119.54 x 78 mm (4.71 x 3.07 inch)



### weight

~120 g (0.264 lbs)

# Package Contains



- 01 Damage resistant protective box



- 02 mikromedia+ for Stellaris® ARM® development system



- 03 DVD with documentation and examples



- 04 mikromedia+ for Stellaris® ARM® user's guide



- 05 mikromedia+ for Stellaris® ARM® schematic



- 06 USB cable and microSD card with adapter

# 1. Power supply

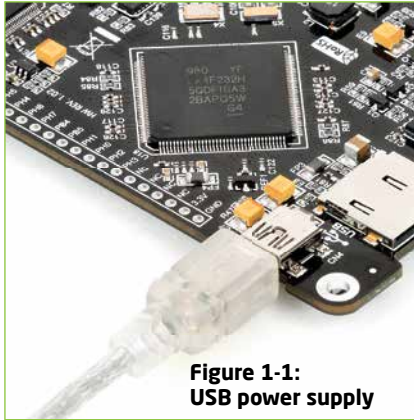

**Figure 1-1:**  
**USB power supply**

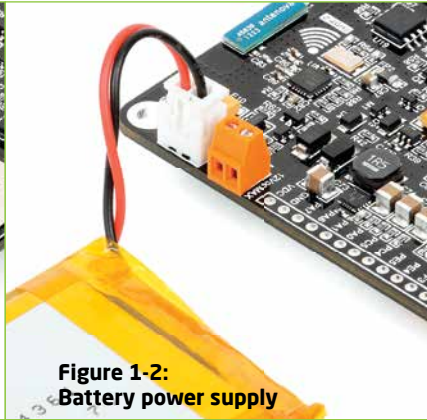

**Figure 1-2:**  
**Battery power supply**

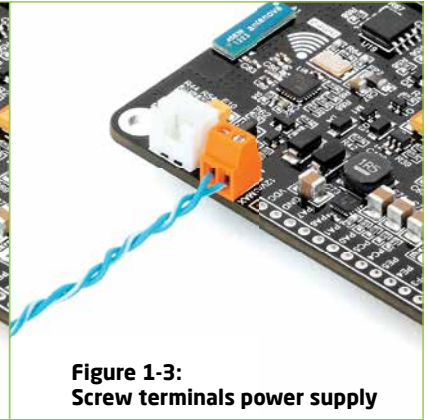

**Figure 1-3:**  
**Screw terminals power supply**

The mikromedia+ for Stellaris® ARM® board can be powered in three different ways: via USB connector using MINI-B USB cable provided with the board (**CN4**), via battery connector using Li-Polymer battery (**CN5**) or via screw terminals using laboratory power supply (**CN3**). After you plug in the appropriate power supply turn the power switch ON (**SW1**). The USB connection can provide up to 500mA of current which is more than enough for the operation of all on-board modules and the microcontroller as well. If you decide to use external power supply via screw terminals, voltage values must be within **2.5-12V DC** range. Power **LED ON (GREEN)** indicates the presence of power supply. On-board battery charger circuit **MCP73832** enables you to charge the battery over USB connection or via screw terminals. **LED diode (RED)** indicates when battery is charging. Charging current is ~250mA and charging voltage is 4.2V DC.

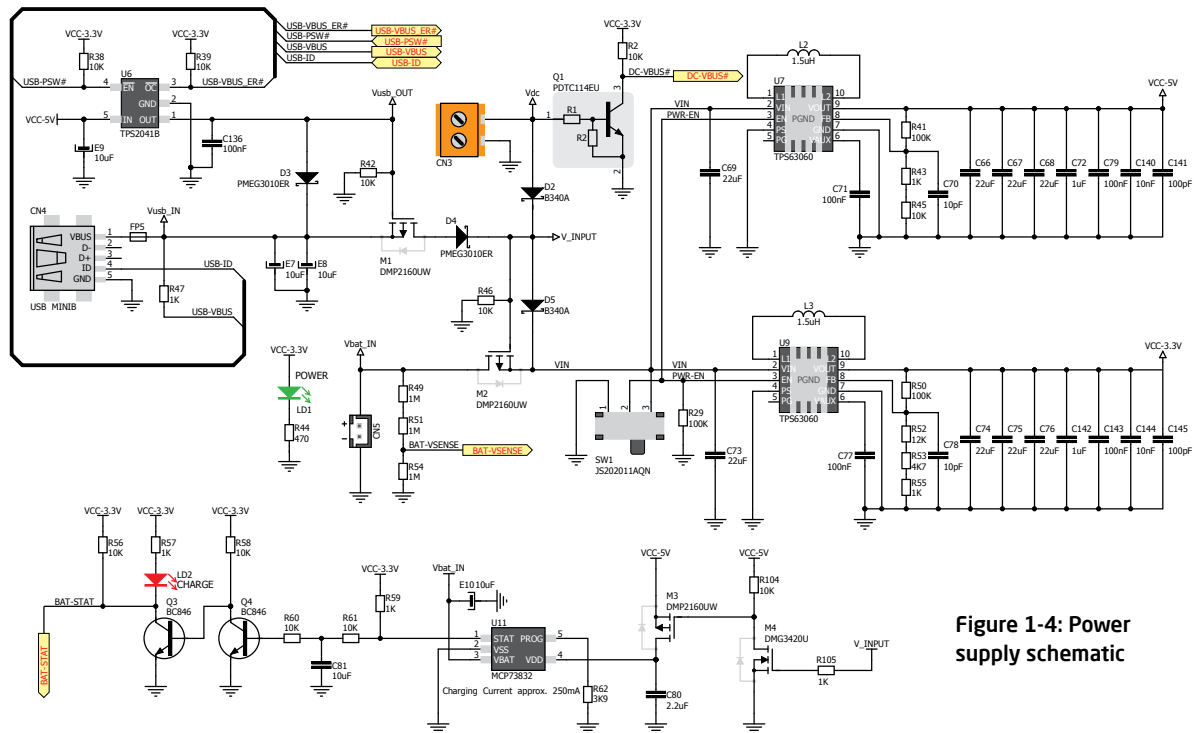

Figure 1-4: Power supply schematic



## 2. LM4F232H5QD microcontroller

The mikromedia+ for Stellaris® ARM® development board comes with the 144-pin **ARM® Cortex™-M4 LM4F232H5QD** microcontroller. This high-performance **32-bit** microcontroller with its integrated modules and in combination with other on-board modules is ideal for multimedia applications.

### Key microcontroller features

- Up to **100 DMIPS** Operation (80MHz);
- 256KB of Flash memory;
- 32KB of SRAM memory;
- 2KB of EEPROM memory;
- up to 105 I/O pins;
- 16/32-bit timers
- 16MHz internal oscillator, 32kHz RTCC;
- 8xUART, 4xSPI, 6xI<sup>2</sup>C, 2xCAN, 2xADC, USB etc.

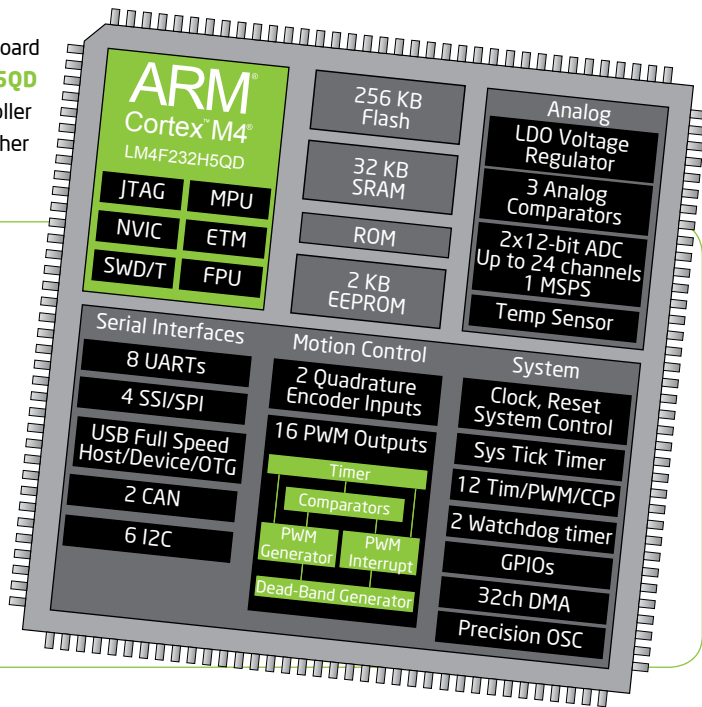

### 3. Programming the microcontroller

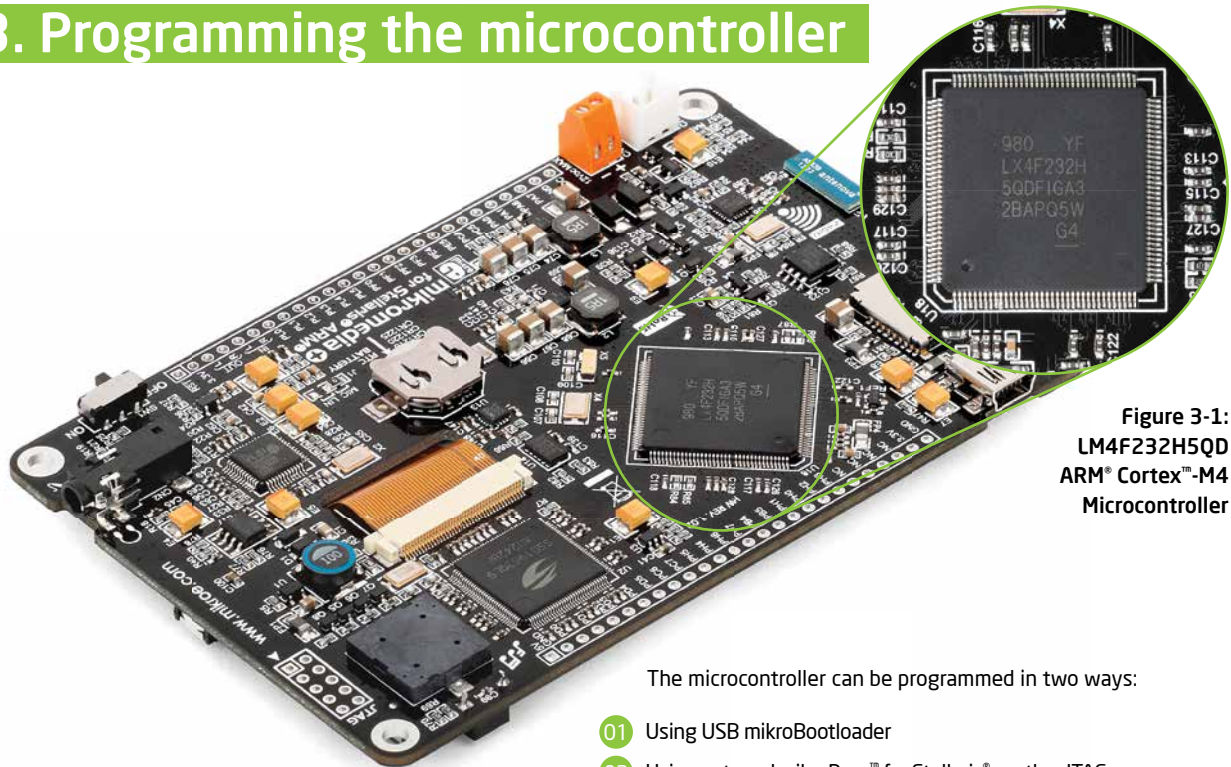

**Figure 3-1:**  
**LM4F232H5QD**  
**ARM® Cortex™-M4**  
**Microcontroller**

The microcontroller can be programmed in two ways:

- 01 Using USB mikroBootloader
- 02 Using external mikroProg™ for Stellaris® or other JTAG programmers

# Programming with mikroBootloader

You can program the microcontroller with bootloader which is pre programmed into the device by default. To transfer .HEX file from a PC to MCU you need bootloader software (**mikroBootloader USB HID**) which can be downloaded from:



[http://www.mikroe.com/downloads/get/1976/mikromedia\\_plus\\_mikrobootloader\\_v210.zip](http://www.mikroe.com/downloads/get/1976/mikromedia_plus_mikrobootloader_v210.zip)

After software is downloaded unzip it to desired location and start mikroBootloader USB HID software.

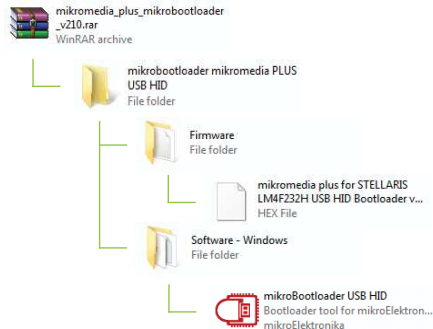

## step 1 - Connecting mikromedia



Figure 3-2: USB HID mikroBootloader window

- 01 To start connect the USB cable or (if already connected) press the **Reset** button on your mikromedia+ board. Click the **Connect** button within 5s to enter the bootloader mode, otherwise existing microcontroller program will execute.

## step 2 - Browsing for .HEX file



Figure 3-3: Browse for HEX

- 01 Click the **Browse for HEX** button and from a pop-up window (**Figure 3.4**) choose the .HEX file that will be uploaded to MCU memory.

## step 3 - Selecting .HEX file

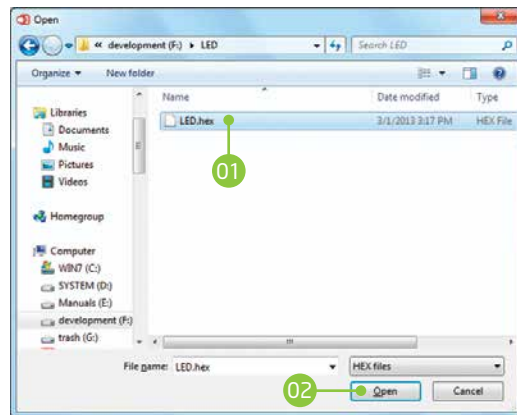

Figure 3-4: Selecting HEX

- 01 Select .HEX file using open dialog window.
- 02 Click the **Open** button.

## step 4 - Uploading .HEX file



Figure 3-5: Begin uploading

- 01 To start .HEX file uploading click the **Begin uploading** button.



Figure 3-6: Progress bar

- 01 You can monitor .HEX file uploading via progress bar

## step 5 - Finish upload



Figure 3-7: Restarting MCU

- 01** Click the **OK** button after uploading is finished. Board will automatically reset and after 5 seconds your new program will execute.



Figure 3-8: mikroBootloader ready for next job

# Programming with mikroProg™ programmer



Figure 3-9:  
mikroProg™  
JTAG connector

The microcontroller can be programmed with external **mikroProg™ for Stellaris® programmer** and **mikroProg Suite™ for ARM® software**. The external programmer is connected to the development system via JTAG connector, **Figure 3-9. mikroProg™** is a fast USB 2.0 programmer with hardware Debugger support. It supports ARM® Cortex™-M3 and Cortex™-M4 microcontrollers from Stellaris®. Outstanding performance, easy operation and elegant design are its key features.

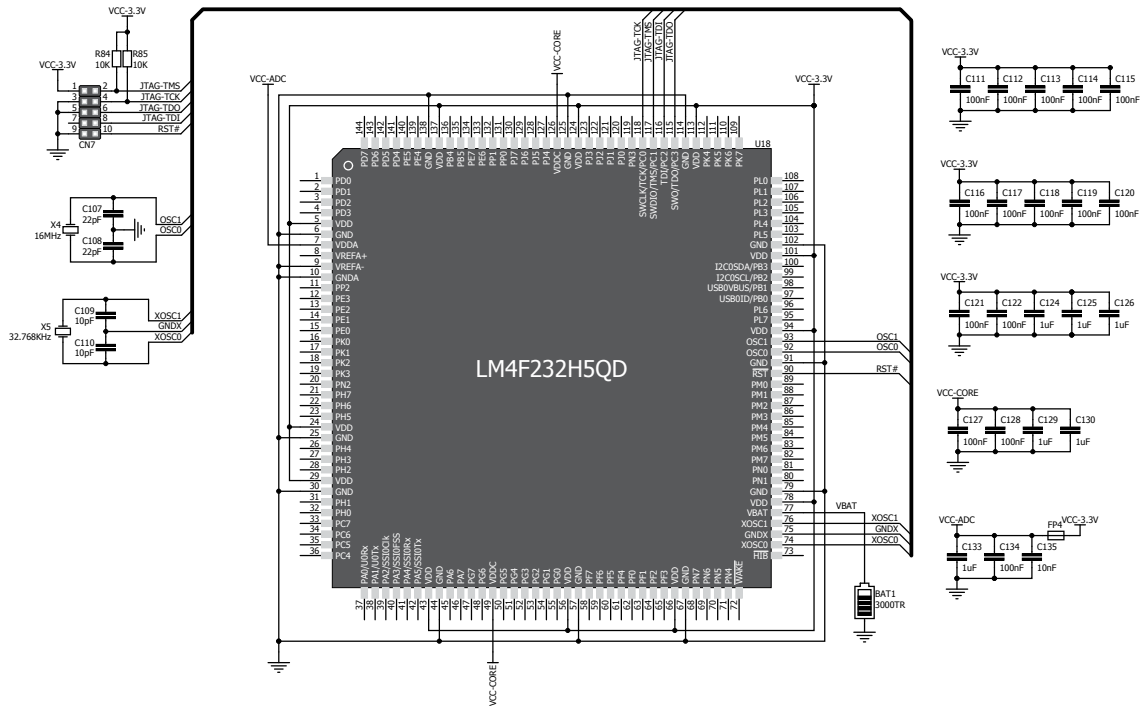

Figure 3-10: mikroProg™ JTAG connector connection schematic



# mikroProg Suite™ for ARM® software



mikroProg™ for Stellaris® programmer requires special programming software called mikroProg Suite™ for ARM®. This software is used for programming ALL of Stellaris® ARM® Cortex-M3™ and Cortex-M4™ microcontroller families. It features intuitive interface and SingleClick™ programming technology. Software installation is available on a Product DVD:



*DVD://download/eng/software/development-tools/arm/stellaris/  
mikroprog/mikroprog\_suite\_for\_arm\_v110.zip*

After downloading, extract the package and double click the executable setup file, to start installation.

## Quick Guide

- 01 Click the **Detect MCU** button in order to recognize the device ID.
- 02 Click the **Read** button to read the entire microcontroller memory. You can click the **Save** button to save it to target HEX file.
- 03 If you want to write the HEX file to the microcontroller, first make sure to load the target HEX file using the **Load** button. Then click the **Write** button to begin programming.
- 04 Click the **Erase** button to wipe out the microcontroller memory.

# Software installation wizard



01 Start Installation



02 Accept EULA and continue

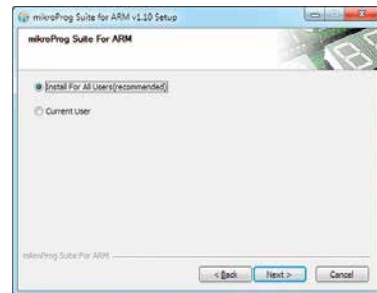

03 Install for all users

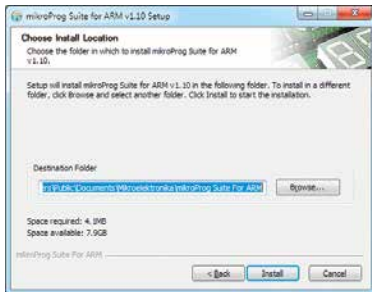

04 Choose destination folder

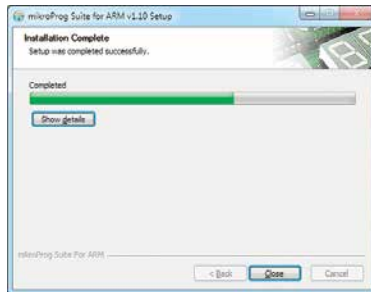

05 Installation in progress



06 Finish installation

## 4. RTC Battery and Reset Button

### Reset Button

The board is equipped with reset button, which is located on the front side of the board. If you want to reset the circuit, press the reset button. It will generate low voltage level on the microcontroller reset pin (input). A reset can also be externally provided through the **pin 27** on the side headers.

### RTC Battery

mikromedia+ for Stellaris® ARM® features an RTC battery holder for microcontroller RTC module. Battery is used as alternate source of power, so the RTC module can continue to keep time while the primacy source of power is off or currently unavailable. Three types of coin battery are supported: CR1216, CR1220 and CR1225.

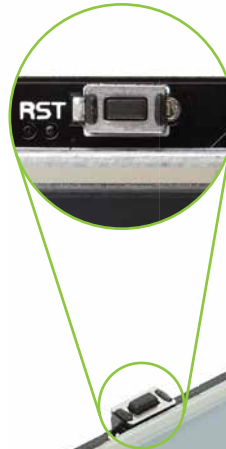
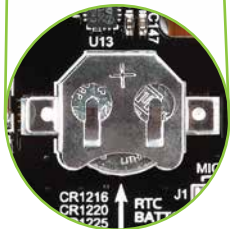

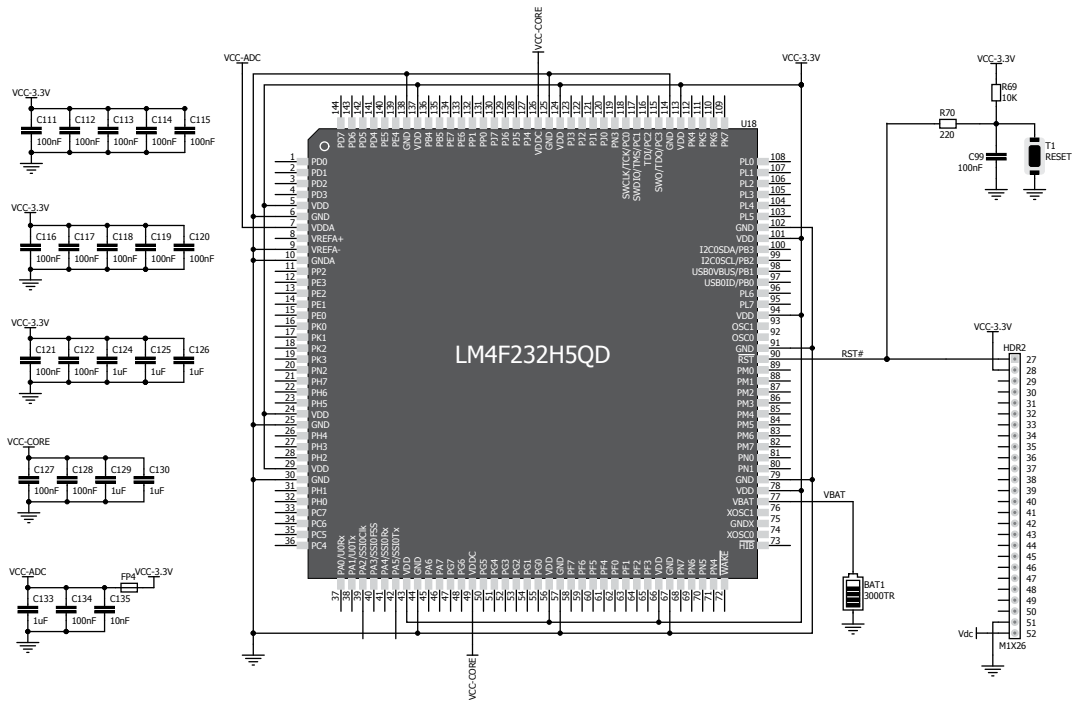

Figure 4-1: Reset circuit and RTC battery schematic

## 5. Crystal oscillator and 2.048V reference

The board is equipped with **01 16MHz crystal oscillator (X4)** circuit that provides external clock waveform to the microcontroller OSC0 and OSC1 pins. This base frequency is suitable for further clock multipliers and ideal for generation of necessary USB clock, which ensures proper operation of bootloader and your custom USB-based applications. The board also contains **02 32.768 kHz crystal oscillator (X5)** which provides external clock for internal RTCC module. Microcontroller ADC requires an accurate source of reference voltage signal. That is why we provide the external **03 voltage reference** to the microcontroller VREF pin which is **2.048V**.

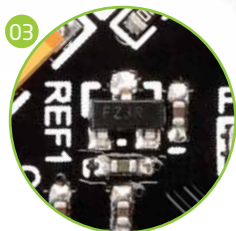
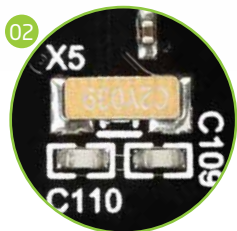
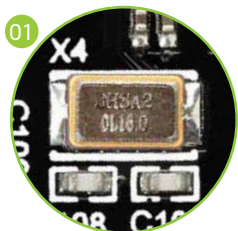
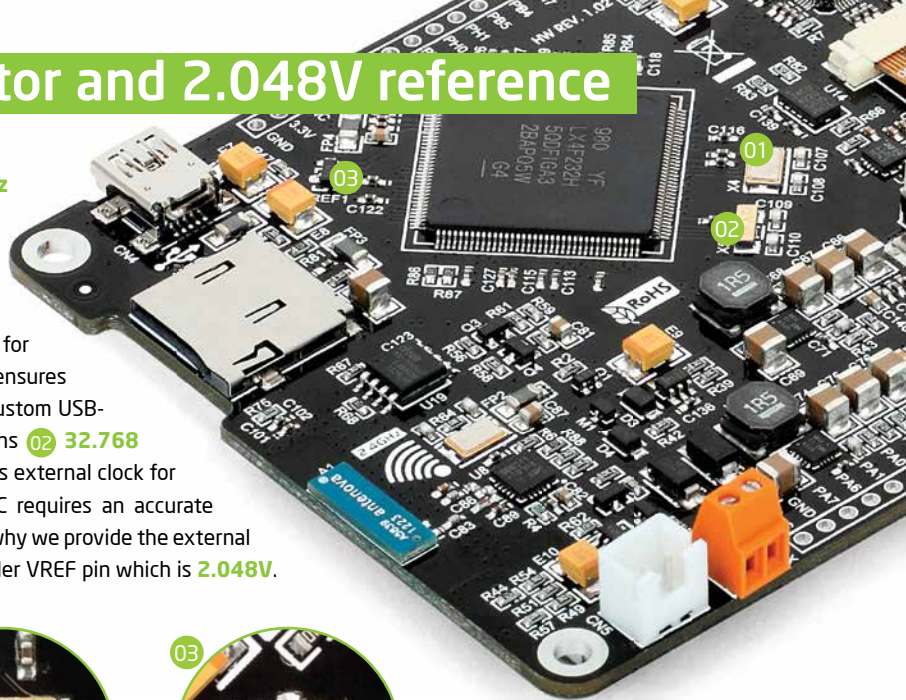
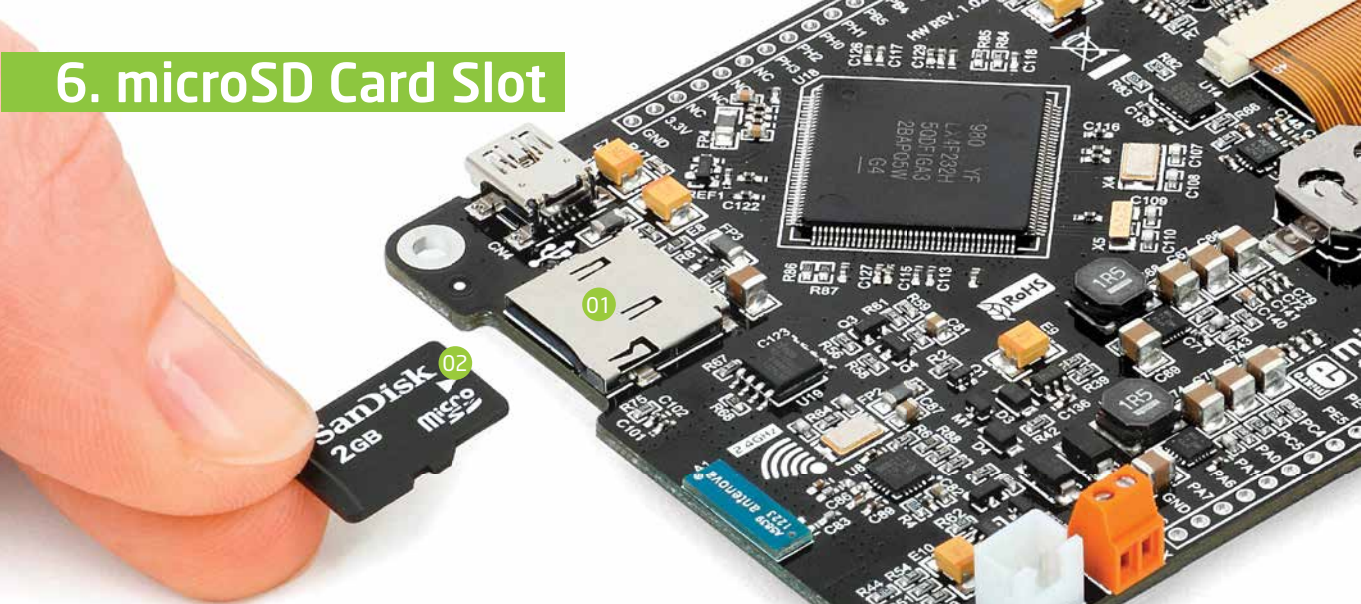

Figure 5-1: Crystal oscillator and 2.048V reference



## 6. microSD Card Slot



Board contains **01** **microSD card slot** for using **02** microSD cards in your projects. It enables you to store large amounts of data externally, thus saving microcontroller memory. microSD cards use Serial Peripheral Interface (**SPI**) for communication with the microcontroller. Ferrite and capacitor are provided to compensate the voltage and current glitch that can occur when pushing-in and pushing-out microSD card into the socket. Proper insertion of the microSD card is shown in **Figure 6-1**.

**Figure 6-1:**  
microSD card slot

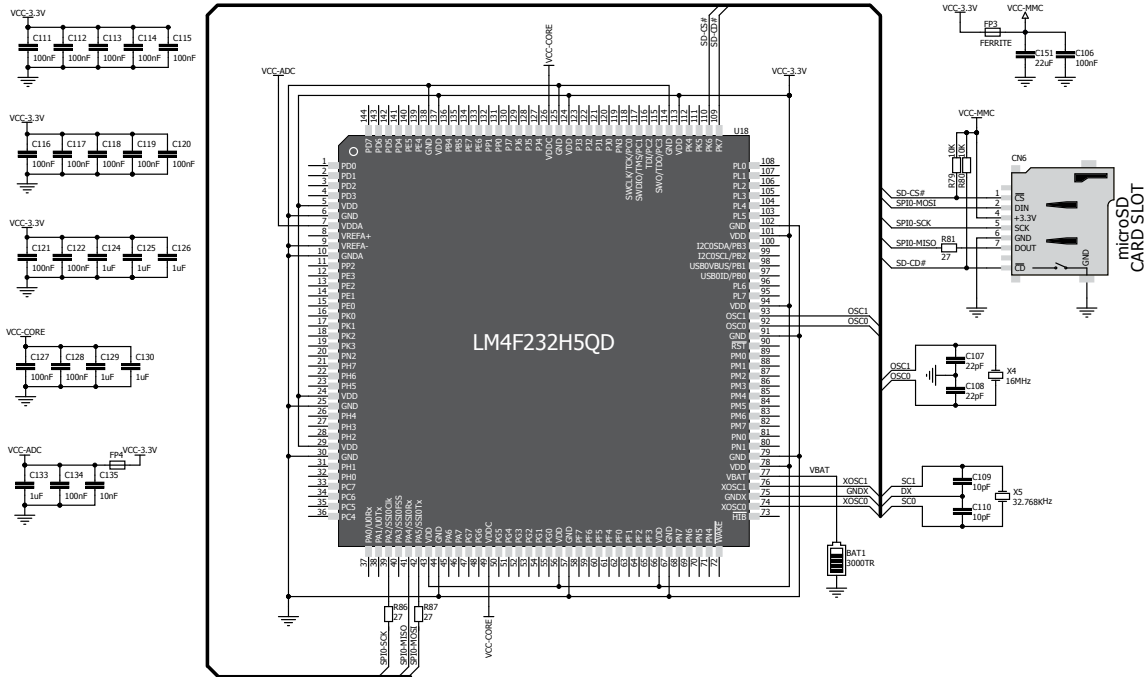

Figure 6-2: microSD Card Slot module connection schematic



## 7. Touch Screen



The development system features a **4.3" TFT 480x272 display** covered with a **resistive** touch panel. Together they form a functional unit called a **touch screen**, **Figure 7-1**. It enables data to be entered and displayed at the same time. The TFT display is capable of showing graphics in **256K** different **colors**.

Figure 7-1: Touch Screen

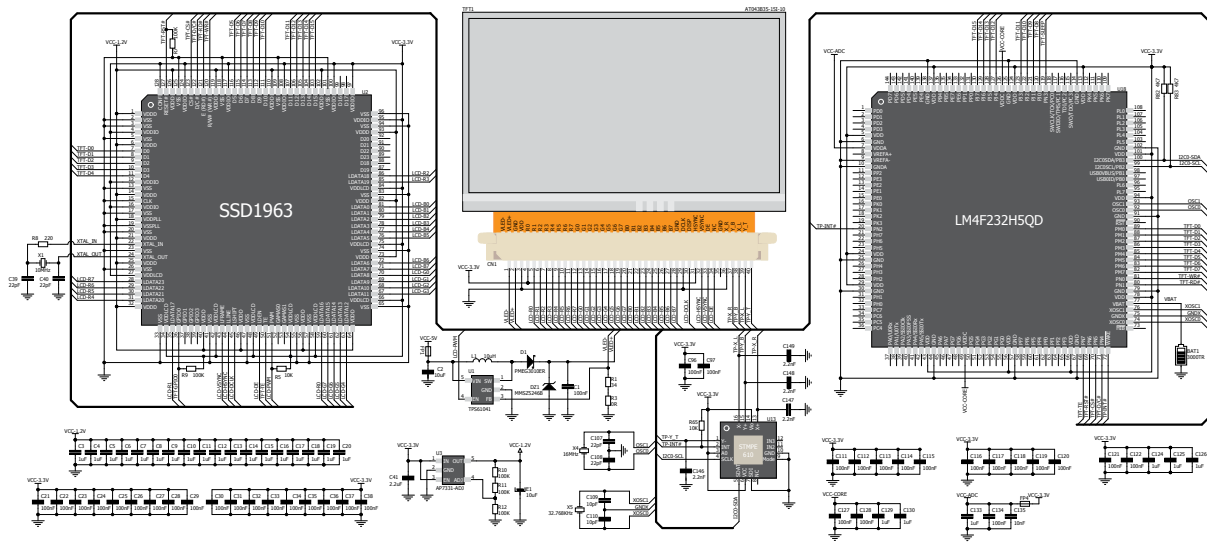

Figure 7-2: Touch Screen connection schematic