



Chipsmall Limited consists of a professional team with an average of over 10 year of expertise in the distribution of electronic components. Based in Hongkong, we have already established firm and mutual-benefit business relationships with customers from,Europe,America and south Asia,supplying obsolete and hard-to-find components to meet their specific needs.

With the principle of “Quality Parts,Customers Priority,Honest Operation,and Considerate Service”,our business mainly focus on the distribution of electronic components. Line cards we deal with include Microchip,ALPS,ROHM,Xilinx,Pulse,ON,Everlight and Freescale. Main products comprise IC,Modules,Potentiometer,IC Socket,Relay,Connector.Our parts cover such applications as commercial,industrial, and automotives areas.

We are looking forward to setting up business relationship with you and hope to provide you with the best service and solution. Let us make a better world for our industry!



Contact us

Tel: +86-755-8981 8866 Fax: +86-755-8427 6832

Email & Skype: info@chipsmall.com Web: www.chipsmall.com

Address: A1208, Overseas Decoration Building, #122 Zhenhua RD., Futian, Shenzhen, China



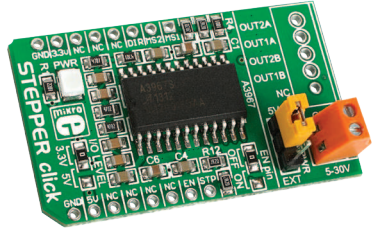

STEPPER click™

1. Introduction

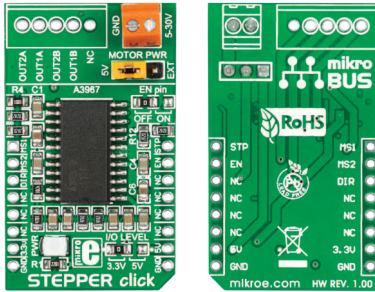

STEPPER click™ is a stepper motor driver board in **mikroBUS™** form factor. It features the **A3967SLBT** microstepping motor driver with a built-in translator. Stepper click communicates with the target board via AN, RST, CS, PWM and INT lines. The board is designed to use 3.3V or 5V power supplies. A LED diode serves as a power indicator.

2. Soldering the headers

Before using your click™ board, make sure to solder 1x8 male headers to both left and right side of the board. Two 1x8 male headers are included with the board in the package.

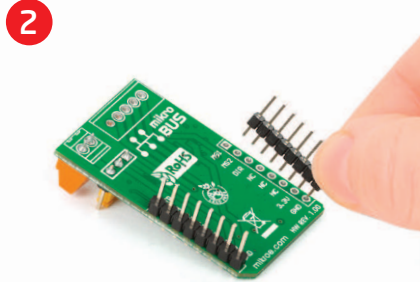
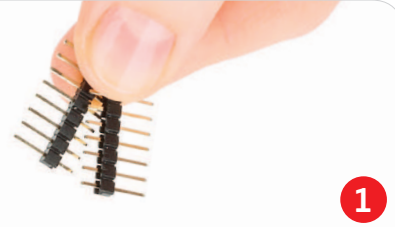

Turn the board upside down so that the bottom side is facing you upwards. Place shorter pins of the header into the appropriate soldering pads

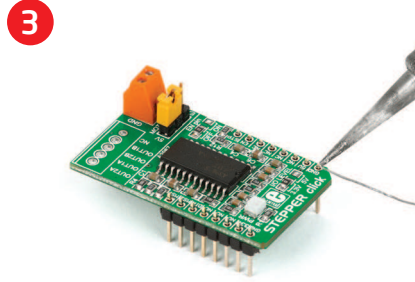

Turn the board upward again. Make sure to align the headers so that they are perpendicular to the board, then solder the pins carefully.

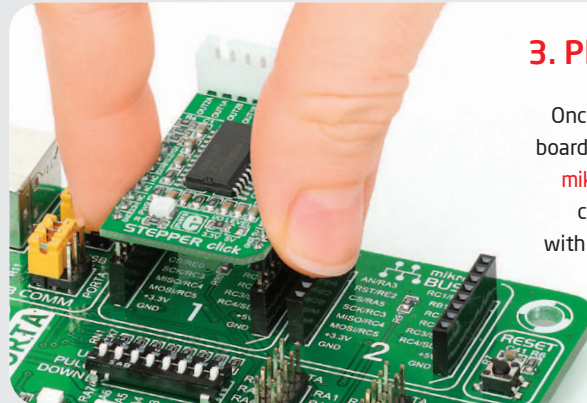

3. Plugging the board in

Once you have soldered the headers your board is ready to be placed into the desired **mikroBUS™** socket. Make sure to align the cut in the lower-right part of the board with the markings on the silkscreen at the **mikroBUS™** socket. If all the pins are aligned correctly, push the board all the way into the socket.

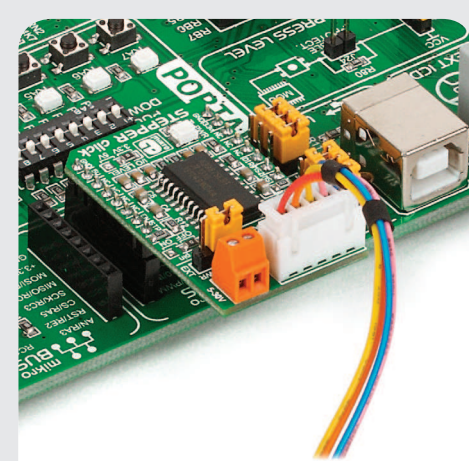

4. Essential features

Stepper Click™ allows you to drive a bipolar step motors in full-, half-, quarter- and eighth-step modes with output drive capability of 30V and about ±500 mA. In order to connect the motor with the board, solder either a B5B-XH-A connector or two screw terminals (both provided with the package). Use jumper **J3** to select whether you want to power the motor driver with the on-board or external power supply connected to the **CN2** screw terminal.

click™
BOARD
www.mikroe.com

STEPPER click Manual
ver. 1.00



5. Stepper Click™ Board Schematic

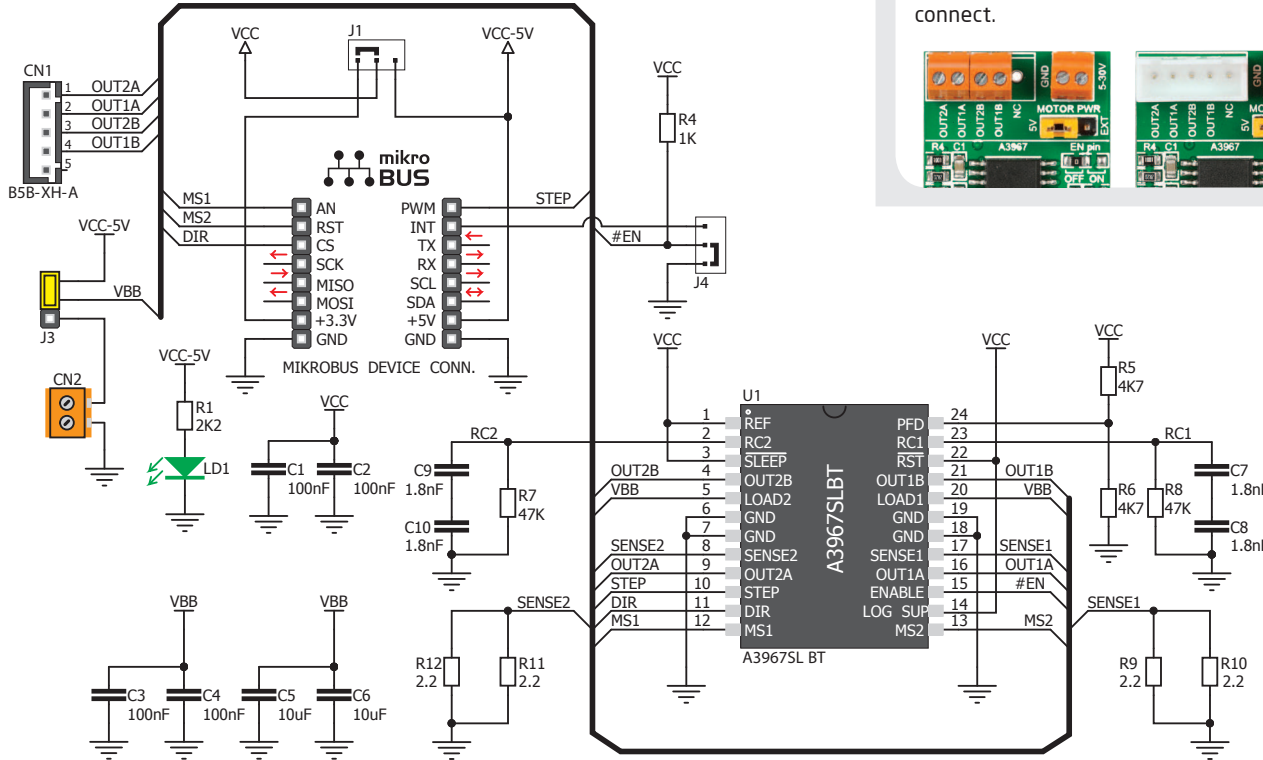

6. Connectors

Two types of connectors are supplied in the package: A B5B-XH-A connector, and two screw terminals. Solder either one or the other depending on the motor you want to connect.

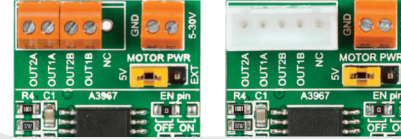

7. SMD Jumpers

If you want to use the motor driver's enable pin (#EN), solder **J4** SMD jumper in ON position. Otherwise leave it in the default OFF position (connected to the ground). There is a single SMD jumper (zero-ohm resistor) **J1** which is used to select between 3.3V or 5V power supplies. By default, it's soldered in the 3.3V position.

8. Code Examples

Once you have done all the necessary preparations, it's time to get your click™ board up and running. We have provided examples for mikroC™, mikroBasic™ and mikroPascal™ compilers on our **Libstock** website. Just download them and you are ready to start.



9. Support

MikroElektronika offers **Free Tech Support** (www.mikroe.com/esupport) until the end of product lifetime, so if something goes wrong, we are ready and willing to help!

