



Chipsmall Limited consists of a professional team with an average of over 10 year of expertise in the distribution of electronic components. Based in Hongkong, we have already established firm and mutual-benefit business relationships with customers from,Europe,America and south Asia,supplying obsolete and hard-to-find components to meet their specific needs.

With the principle of "Quality Parts,Customers Priority,Honest Operation,and Considerate Service",our business mainly focus on the distribution of electronic components. Line cards we deal with include Microchip,ALPS,ROHM,Xilinx,Pulse,ON,Everlight and Freescale. Main products comprise IC,Modules,Potentiometer,IC Socket,Relay,Connector.Our parts cover such applications as commercial,industrial, and automotives areas.

We are looking forward to setting up business relationship with you and hope to provide you with the best service and solution. Let us make a better world for our industry!



Contact us

Tel: +86-755-8981 8866 Fax: +86-755-8427 6832

Email & Skype: info@chipsmall.com Web: www.chipsmall.com

Address: A1208, Overseas Decoration Building, #122 Zhenhua RD., Futian, Shenzhen, China



Serial LCD/GLCD Adapter™

Manual

All Mikroelektronika's development systems feature a large number of peripheral modules expanding microcontroller's range of application and making the process of program testing easier. In addition to these modules, it is also possible to use numerous additional modules linked to the development system through the I/O port connectors. Some of these additional modules can operate as stand-alone devices without being connected to the microcontroller.

Additional Board

 **MikroElektronika**

SOFTWARE AND HARDWARE SOLUTIONS FOR EMBEDDED WORLD ...making it simple

Serial LCD/GLCD Adapter Additional Board

The *Serial LCD/GLCD Adapter* additional board is used to connect a 128x64 GLCD display to a development system. Communication with development systems is performed via a Serial Peripheral Interface (SPI). The additional board is connected to a development system via an IDC10 connector on the flat cable, whereas an on-board 1x20 male connector is used to connect an LCD or a GLCD display. Depending on the display in use, it is necessary to place jumper J1 in the appropriate position. When an LCD display is connected to the board, jumper J1 should be set to the CHAR position. In case a GLCD display is connected, jumper J1 should be placed in the GRAPH position. Potentiometer P1 is used for LCD/GLCD display contrast adjustment. The additional board is configured for PIC development systems by default. In case some other development systems are used, such as AVR or 8051, it is necessary to unsolder jumpers from the PIC position and resolder them in the AVR/8051 position.

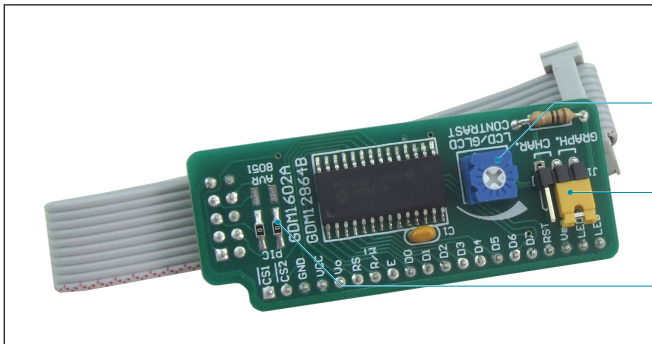

Potentiometer used to adjust LCD/GLCD display contrast

Jumper J1 used to select a display to be connected to the board

Jumpers used to select a development system to be connected to the board

Figure 1: Serial LCD/GLCD Adapter additional board



1x20 male connector enables connection of LCD/GLCD

IDC10 connector enables the additional board to be connected to a development system

Figure 2: Back of the Serial LCD/GLCD Adapter additional board

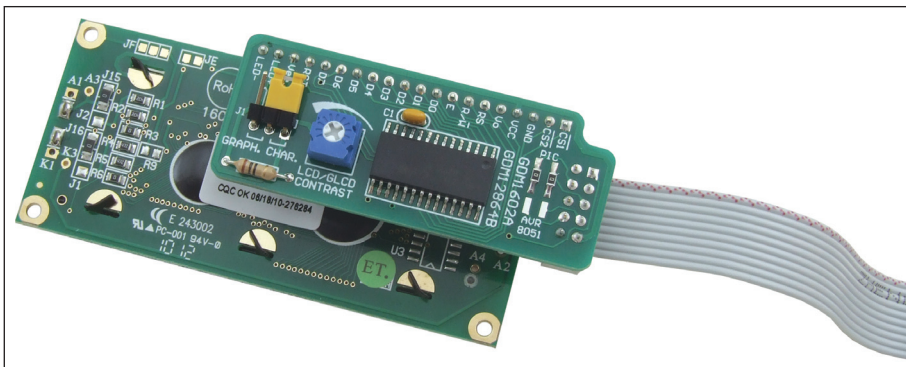

Figure 3: Serial LCD/GLCD Adapter additional board with a 2x16 LCD (jumper J1 in CHAR position)

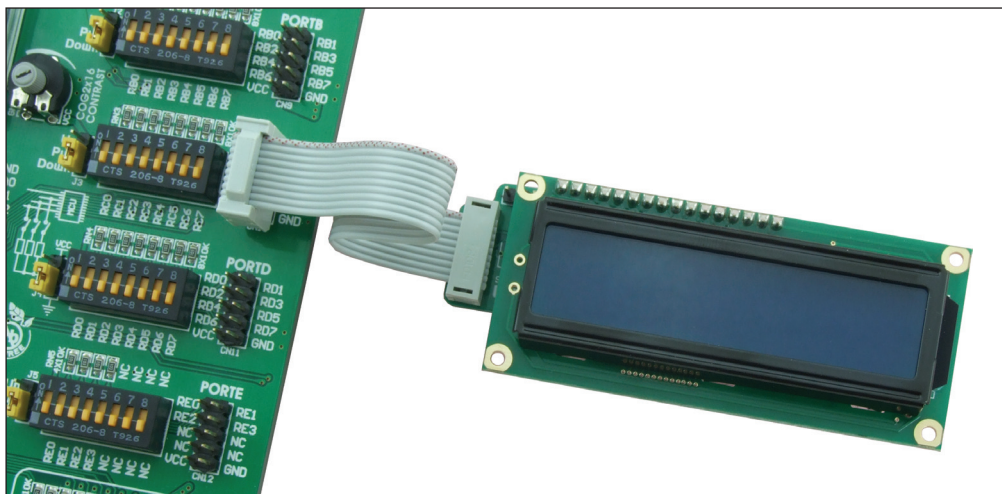

Figure 4: Serial LCD/GLCD Adapter additional board with a 2x16 LCD connected to a development system

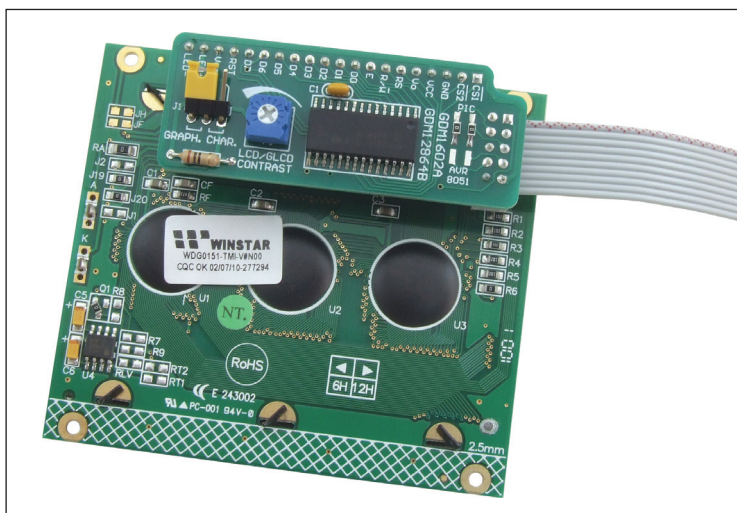

Figure 5: Serial LCD/GLCD Adapter additional board with a 128x64 GLCD (jumper J1 in GRAPH position)

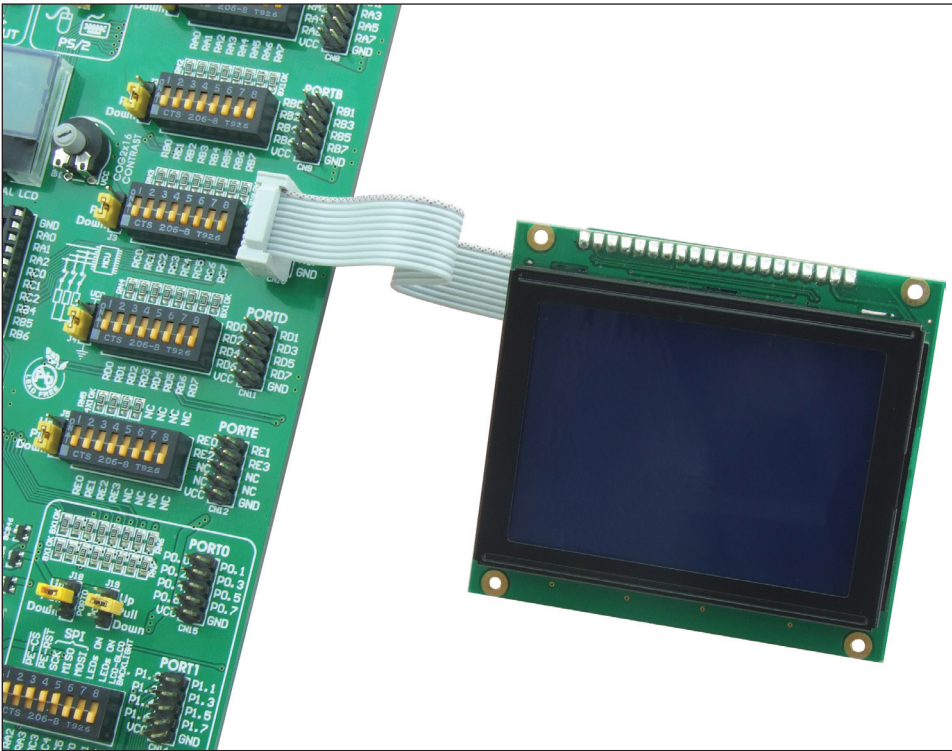

Figure 6: Serial LCD/GLCD Adapter additional board with a 128x64 GLCD connected to a development system

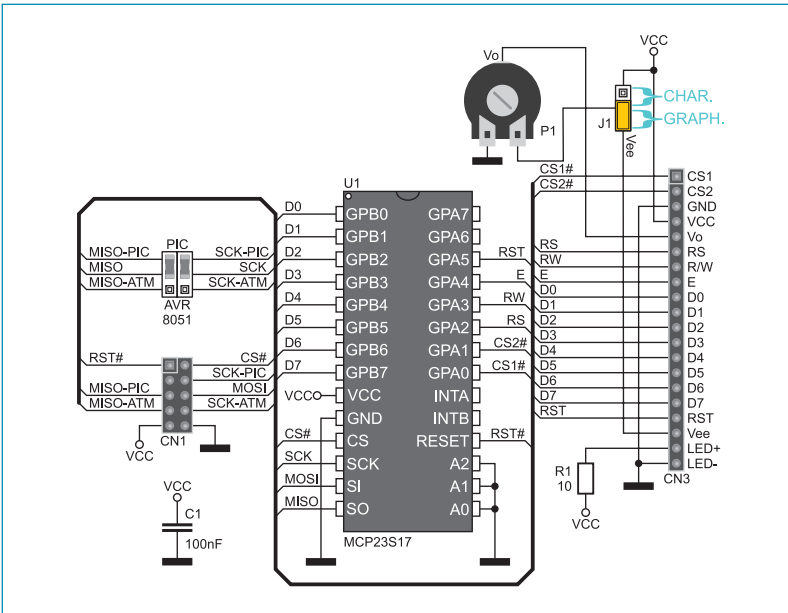

Figure 7: Serial LCD/GLCD Adapter additional board connection schematic

If you want to learn more about our products, please visit our website at www.mikroe.com

If you are experiencing some problems with any of our products or just need additional information, please place your ticket at www.mikroe.com/en/support

If you have any questions, comments or business proposals, do not hesitate to contact us at office@mikroe.com