



Chipsmall Limited consists of a professional team with an average of over 10 year of expertise in the distribution of electronic components. Based in Hongkong, we have already established firm and mutual-benefit business relationships with customers from,Europe,America and south Asia,supplying obsolete and hard-to-find components to meet their specific needs.

With the principle of “Quality Parts,Customers Priority,Honest Operation,and Considerate Service”,our business mainly focus on the distribution of electronic components. Line cards we deal with include Microchip,ALPS,ROHM,Xilinx,Pulse,ON,Everlight and Freescale. Main products comprise IC,Modules,Potentiometer,IC Socket,Relay,Connector.Our parts cover such applications as commercial,industrial, and automotives areas.

We are looking forward to setting up business relationship with you and hope to provide you with the best service and solution. Let us make a better world for our industry!



## Contact us

Tel: +86-755-8981 8866 Fax: +86-755-8427 6832

Email & Skype: info@chipsmall.com Web: www.chipsmall.com

Address: A1208, Overseas Decoration Building, #122 Zhenhua RD., Futian, Shenzhen, China





## XBEE click

### 2. Soldering the headers

Before using your click board™, make sure to solder 1x8 male headers to both left and right side of the board. Two 1x8 male headers are included with the board in the package.

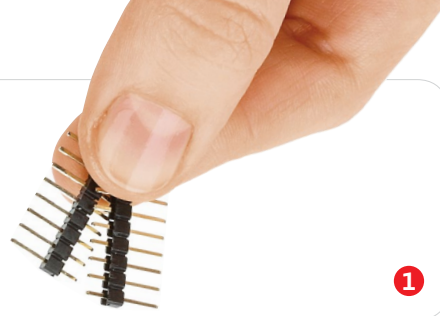

1

2



Turn the board upside down so that the bottom side is facing you upwards. Place shorter pins of the header into the appropriate soldering pads.

3

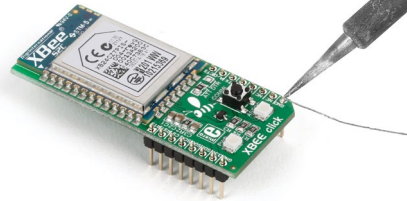

Turn the board upward again. Make sure to align the headers so that they are perpendicular to the board, then solder the pins carefully.

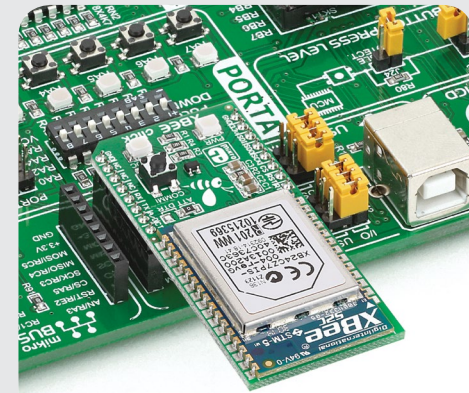

### 4. Essential features

XBee click is network-compatible with other devices that conform to ZigBee standards. The module operates at the 2.4–2.5GHz band, has a wireless range of up to 60m indoors, or up to 1.2km outdoors (line-of-sight). The RF data rate is up to 250 Kbps. To simplify deployment, the click features a commissioning button and an associated LED. They allow you to issue simple configuration commands with subsequent button presses (joining or leaving networks, self-identification, restoring default values etc.)

### 1. Introduction

XBee click carries the Xbee® and Zigbee-compliant XB24CZ7PIS-004 module with a PCB antenna from Digi International. The module provides wireless connectivity to end-point devices in ZigBee mesh networks. The board can communicate with the target MCU either through the mikroBUS™ UART interface (TX, RX, RTS i CTS), or SPI (MISO, MOSI, SCK, CS). Additional functionality is provided by, Reset, and ATTN-DTR pins. Uses 3.3V power supply only.

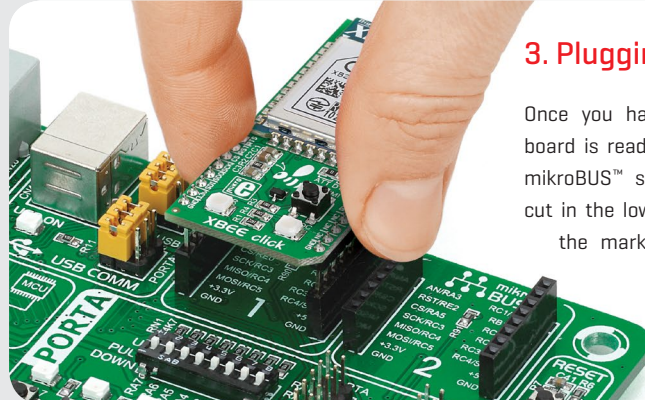

### 3. Plugging the board in

Once you have soldered the headers your board is ready to be placed into the desired mikroBUS™ socket. Make sure to align the cut in the lower-right part of the board with the markings on the silkscreen at the mikroBUS™ socket. If all the pins are aligned correctly, push the board all the way into the socket.



XBEE click Manual v101



010000090060

## 5. Schematic

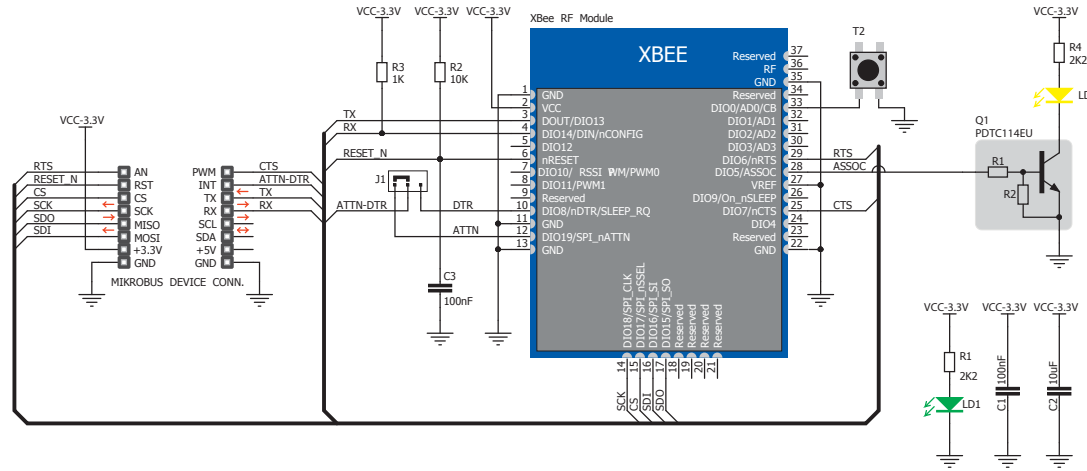

## 6. Dimensions



	mm	mils
LENGTH	57.15	2250
WIDTH	25.4	1000
HEIGHT*	5.33	210

\* without headers

## 7. ATT/DTR jumper



The ATT/DTR jumper is for setting the interrupt feature, depending on whether SPI or UART is used for data transmission (ATT for SPI, DTR for UART).

## 8. Code examples

Once you have done all the necessary preparations, it's time to get your click board™ up and running. We have provided examples for mikroC™, mikroBasic™ and mikroPascal™ compilers on our **Libstock** website. Just download them and you are ready to start.



## 9. Support

MikroElektronika offers **free tech support** [[www.mikroe.com/support](http://www.mikroe.com/support)] until the end of the product's lifetime, so if something goes wrong, we're ready and willing to help!



## 10. Disclaimer

MikroElektronika assumes no responsibility or liability for any errors or inaccuracies that may appear in the present document. Specification and information contained in the present schematic are subject to change at any time without notice.

Copyright © 2015 MikroElektronika.  
All rights reserved.