



Chipsmall Limited consists of a professional team with an average of over 10 year of expertise in the distribution of electronic components. Based in Hongkong, we have already established firm and mutual-benefit business relationships with customers from,Europe,America and south Asia,supplying obsolete and hard-to-find components to meet their specific needs.

With the principle of “Quality Parts,Customers Priority,Honest Operation,and Considerate Service”,our business mainly focus on the distribution of electronic components. Line cards we deal with include Microchip,ALPS,ROHM,Xilinx,Pulse,ON,Everlight and Freescale. Main products comprise IC,Modules,Potentiometer,IC Socket,Relay,Connector.Our parts cover such applications as commercial,industrial, and automotives areas.

We are looking forward to setting up business relationship with you and hope to provide you with the best service and solution. Let us make a better world for our industry!



Contact us

Tel: +86-755-8981 8866 Fax: +86-755-8427 6832

Email & Skype: info@chipsmall.com Web: www.chipsmall.com

Address: A1208, Overseas Decoration Building, #122 Zhenhua RD., Futian, Shenzhen, China



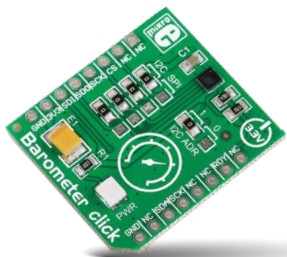

Barometer click

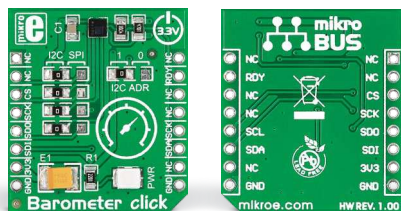

1. Introduction

Barometer click carries the **LPS25HB** IC, which is a piezoresistive absolute pressure sensor with a measurement range from 260 to 1260 hPa (with a 24-bit resolution output). Barometer click communicates with the target board microcontroller either through mikroBUS I²C (SCL, SDA) or SPI pins (MISO, MOSI, SCK, CS). Additionally, there's a Data Ready Interrupt pin. It's designed to use a 3.3V power supply only.

2. Soldering the headers

Before using your click board™, make sure to solder 1x8 male headers to both left and right side of the board. Two 1x8 male headers are included with the board in the package.

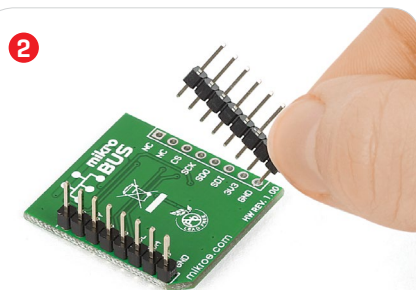
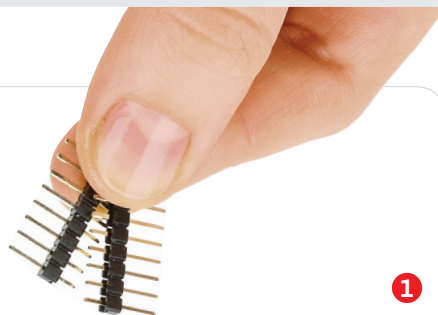

Turn the board upside down so that the bottom side is facing you upwards. Place shorter pins of the header into the appropriate soldering pads.

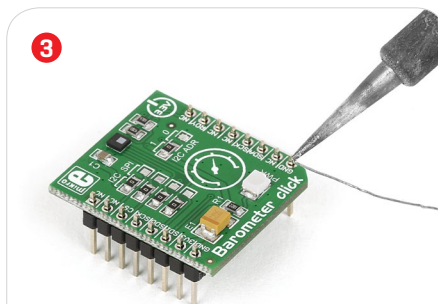

Turn the board upward again. Make sure to align the headers so that they are perpendicular to the board, then solder the pins carefully.

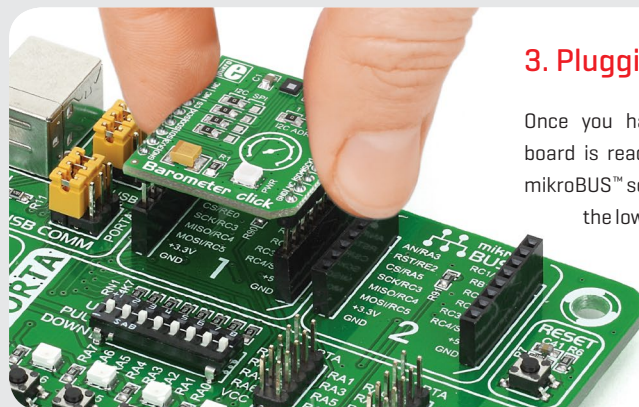

3. Plugging the board in

Once you have soldered the headers your board is ready to be placed into the desired mikroBUS™ socket. Make sure to align the cut in the lower-right part of the board with the markings on the silkscreen at the mikroBUS™ socket. If all the pins are aligned correctly, push the board all the way into the socket.

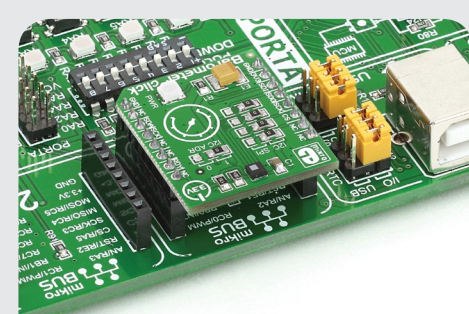

4. Essential features

LPS25HB is a high precision sensor. It's suitable for adding barometer or altimeter function to your design (altitude measurement for wearables, weather station equipment etc.). In high resolution mode it can measure pressure within 0.01 hPa RMS. A low resolution mode can be implemented to reduce power consumption. To further optimize power consumption, a Data Ready function can be used to send an interrupt whenever the pressure value changes. The interrupt can also be configured to send a signal whenever a specified high or low pressure threshold is reached.

click
BOARD™
www.mikroe.com



Barometer click manual
ver 1.00



010000074879

5. Schematic

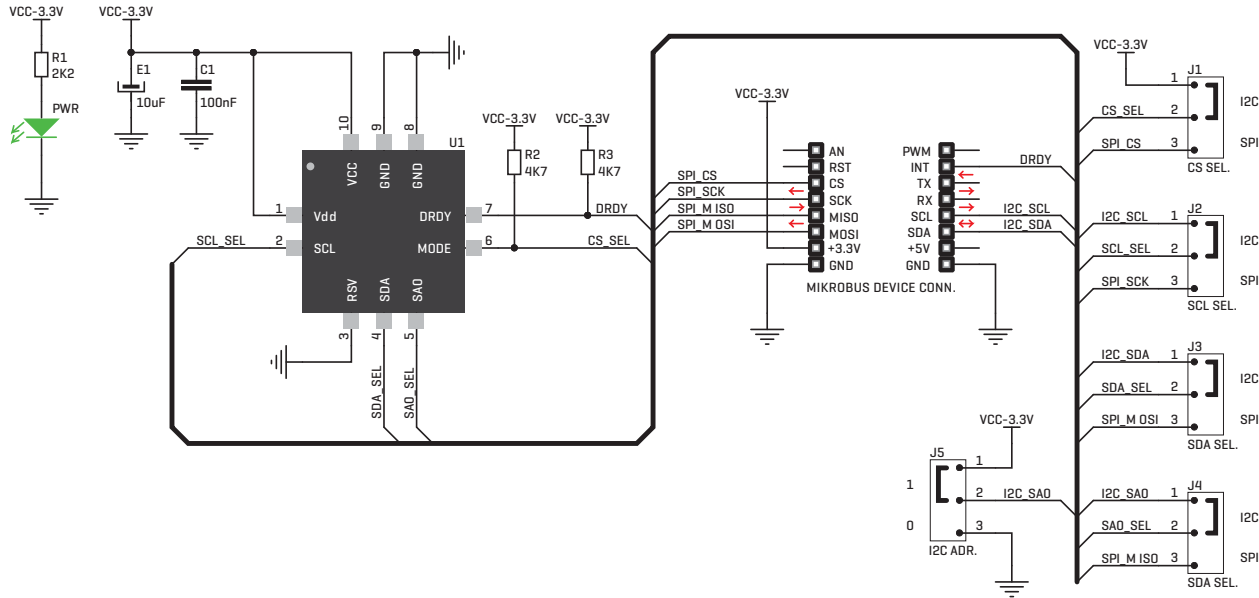

6. Dimensions

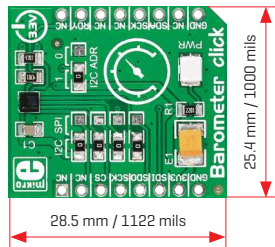

	mm	mils
LENGTH	28.5	1122
WIDTH	25.4	1000
HEIGHT*	3.6	142

* without headers

7. SMD jumpers

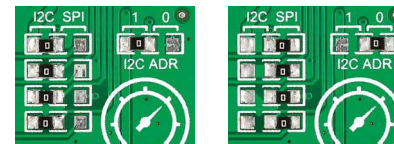

Barometer click features two sets of jumpers. Three jumpers for switching between SPI and I²C interfaces (soldered in I²C by default), and an I²C ADDR is for specifying the I²C address.

8. Code examples

Once you have done all the necessary preparations, it's time to get your click board™ up and running. We have provided examples for mikroC™, mikroBasic™ and mikroPascal™ compilers on our **Libstock** website. Just download them and you are ready to start.



9. Support

MikroElektronika offers **free tech support** [www.mikroe.com/support] until the end of the product's lifetime, so if something goes wrong, we're ready and willing to help!



10. Disclaimer

MikroElektronika assumes no responsibility or liability for any errors or inaccuracies that may appear in the present document. Specification and information contained in the present schematic are subject to change at any time without notice.

Copyright © 2015 MikroElektronika.
All rights reserved.