



Chipsmall Limited consists of a professional team with an average of over 10 year of expertise in the distribution of electronic components. Based in Hongkong, we have already established firm and mutual-benefit business relationships with customers from,Europe,America and south Asia,supplying obsolete and hard-to-find components to meet their specific needs.

With the principle of “Quality Parts,Customers Priority,Honest Operation,and Considerate Service”,our business mainly focus on the distribution of electronic components. Line cards we deal with include Microchip,ALPS,ROHM,Xilinx,Pulse,ON,Everlight and Freescale. Main products comprise IC,Modules,Potentiometer,IC Socket,Relay,Connector.Our parts cover such applications as commercial,industrial, and automotives areas.

We are looking forward to setting up business relationship with you and hope to provide you with the best service and solution. Let us make a better world for our industry!



Contact us

Tel: +86-755-8981 8866 Fax: +86-755-8427 6832

Email & Skype: info@chipsmall.com Web: www.chipsmall.com

Address: A1208, Overseas Decoration Building, #122 Zhenhua RD., Futian, Shenzhen, China



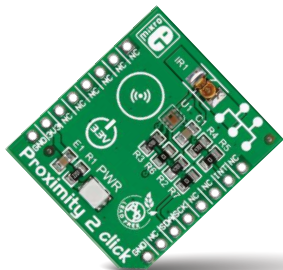

Proximity 2 click™

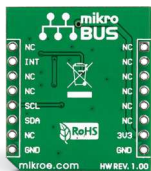
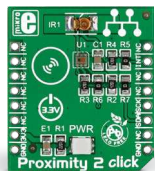

1. Introduction

Proximity 2 click™ features **MAX44000**, an IC that integrates a **proximity** as well as an **ambient light sensor**. The light sensor has a **dynamic range of 0.03 to 65.535 lux**. The IR proximity detector is matched with an integrated IR LED driver [for the **onboard high power infrared LED**]. The detecting range is Proximity 2 click™ communicates with the target board microcontroller through mikroBUS™ I2C [SCL, SDA], and INT lines. It's designed to use a 3.3V power supply only.

2. Soldering the headers

Before using your click™ board, make sure to solder 1x8 male headers to both left and right side of the board. Two 1x8 male headers are included with the board in the package.

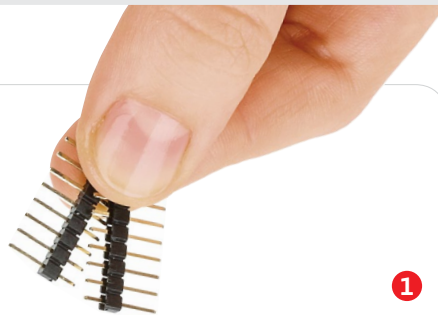

1

2

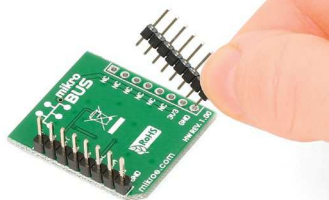

Turn the board upside down so that the bottom side is facing you upwards. Place shorter pins of the header into the appropriate soldering pads.

3

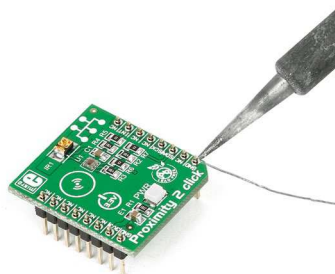

Turn the board upward again. Make sure to align the headers so that they are perpendicular to the board, then solder the pins carefully.

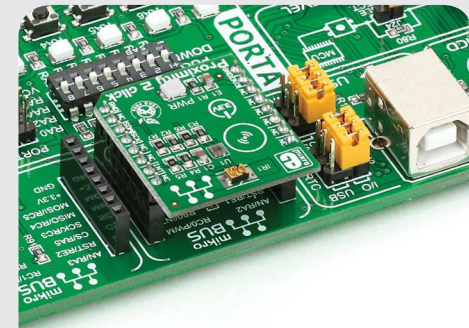

4. Essential features

Proximity 2 click™ is an excellent prototyping platform for the MAX44000 IC. The chip [in a optically transparent package contains an **array of photodiodes** that convert light to current, which is in turn converted into a digital value. With only a **2mm x 2mm footprint**, MAX44000 is ideal for handheld accessories [smartphones and similar]. The wide range and low power consumption makes the sensor suitable for presence and ambient detection in industrial sensors as well.

3. Plugging the board in

Once you have soldered the headers your board is ready to be placed into the desired mikroBUS™ socket. Make sure to align the cut in the lower-right part of the board with the markings on the silkscreen at the mikroBUS™ socket. If all the pins are aligned correctly, push the board all the way into the socket.

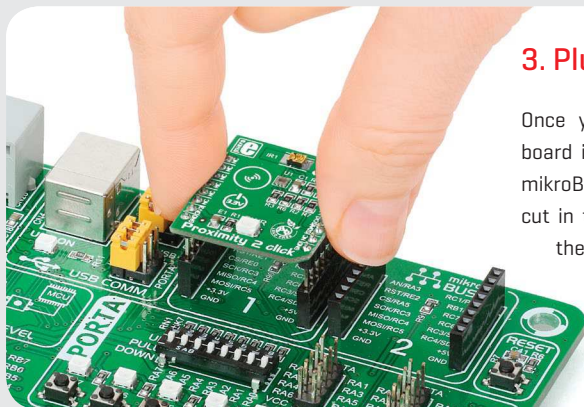

click™
BOARD
www.mikroe.com



Proximity 2 click Manual v100



0100000077092

5. Schematic

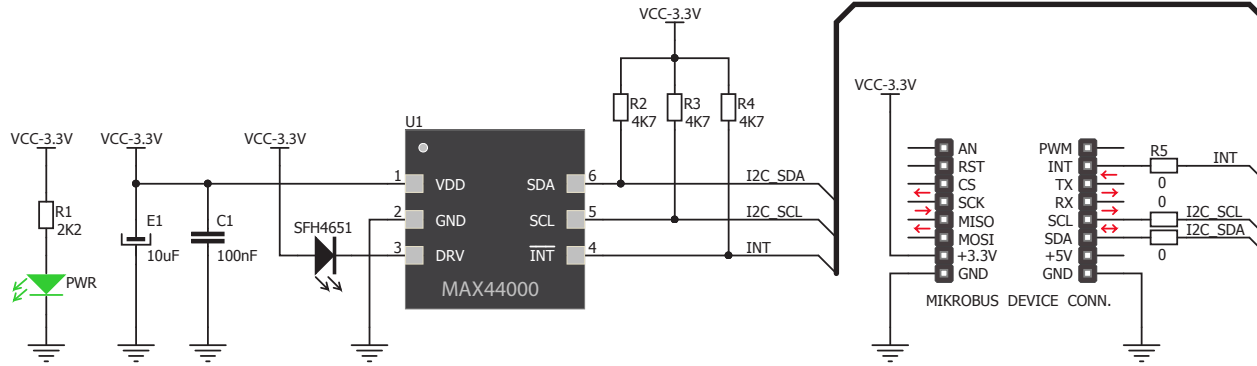

6. Dimensions

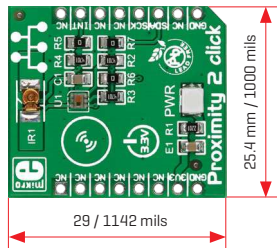

	mm	mils
LENGTH	29	1142
WIDTH	25.4	1000
HEIGHT*	3	118

* without headers

7. Alternative proximity click™

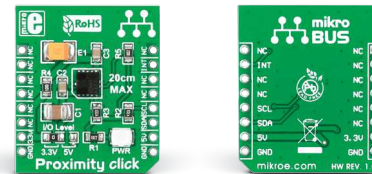

An alternative proximity sensor on a click™ board carries the VCNL4010 IC. See it at: www.mikroe.com/click/proximity

8. Code examples

Once you have done all the necessary preparations, it's time to get your click™ board up and running. We have provided examples for mikroC™, mikroBasic™ and mikroPascal™ compilers on our **Libstock** website. Just download them and you are ready to start.



9. Support

MikroElektronika offers **free tech support** [www.mikroe.com/support] until the end of the product's lifetime, so if something goes wrong, we're ready and willing to help!



10. Disclaimer

MikroElektronika assumes no responsibility or liability for any errors or inaccuracies that may appear in the present document. Specification and information contained in the present schematic are subject to change at any time without notice.

Copyright © 2015 MikroElektronika.
All rights reserved.