



Chipsmall Limited consists of a professional team with an average of over 10 year of expertise in the distribution of electronic components. Based in Hongkong, we have already established firm and mutual-benefit business relationships with customers from,Europe,America and south Asia,supplying obsolete and hard-to-find components to meet their specific needs.

With the principle of “Quality Parts,Customers Priority,Honest Operation,and Considerate Service”,our business mainly focus on the distribution of electronic components. Line cards we deal with include Microchip,ALPS,ROHM,Xilinx,Pulse,ON,Everlight and Freescale. Main products comprise IC,Modules,Potentiometer,IC Socket,Relay,Connector.Our parts cover such applications as commercial,industrial, and automotives areas.

We are looking forward to setting up business relationship with you and hope to provide you with the best service and solution. Let us make a better world for our industry!



Contact us

Tel: +86-755-8981 8866 Fax: +86-755-8427 6832

Email & Skype: info@chipsmall.com Web: www.chipsmall.com

Address: A1208, Overseas Decoration Building, #122 Zhenhua RD., Futian, Shenzhen, China



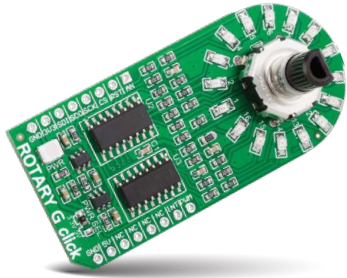

ROTARY G click™

1. Introduction

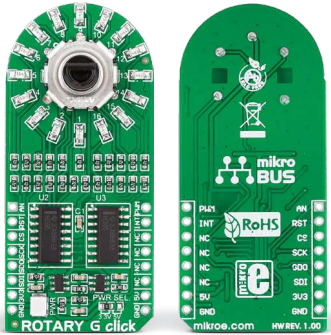

Rotary G click™ carries a **15-pulse incremental rotary encoder** with detents, surrounded by a **ring of 16 green LEDs**. It communicates with the target board through mikroBUS™ **SPI lines** (CS, SCK, MISO, MOSI), and three additional lines for outputting the Encoder info: ENCB OUT, ENCA OUT and SW (in place of the standard AN, RST and INT pins, respectively). Rotary G click™ can be used with either a 3.3V or 5V power supply.

2. Soldering the headers

Before using your click™ board, make sure to solder 1x8 male headers to both left and right side of the board. Two 1x8 male headers are included with the board in the package.

2

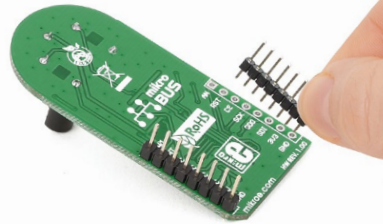

Turn the board upside down so that the bottom side is facing you upwards. Place shorter pins of the header into the appropriate soldering pads.

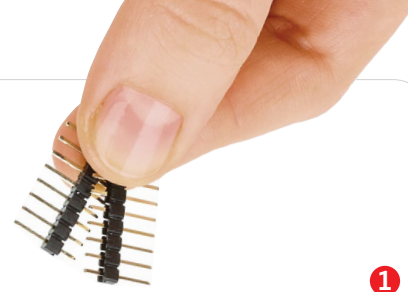

1

3

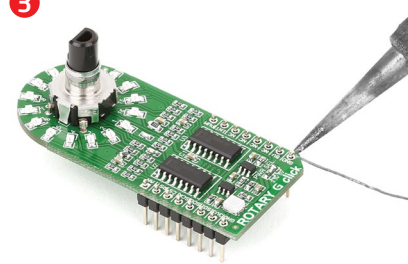

Turn the board upward again. Make sure to align the headers so that they are perpendicular to the board, then solder the pins carefully.

3. Plugging the board in

Once you have soldered the headers your board is ready to be placed into the desired mikroBUS™ socket. Make sure to align the cut in the lower-right part of the board with the markings on the silkscreen at the mikroBUS™ socket. If all the pins are aligned correctly, push the board all the way into the socket.

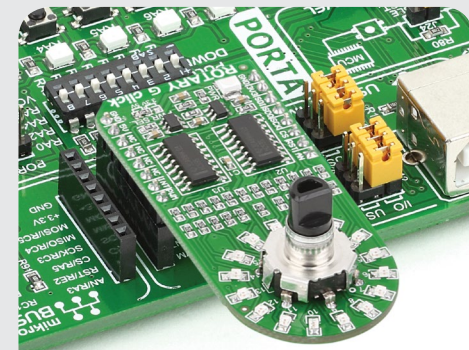
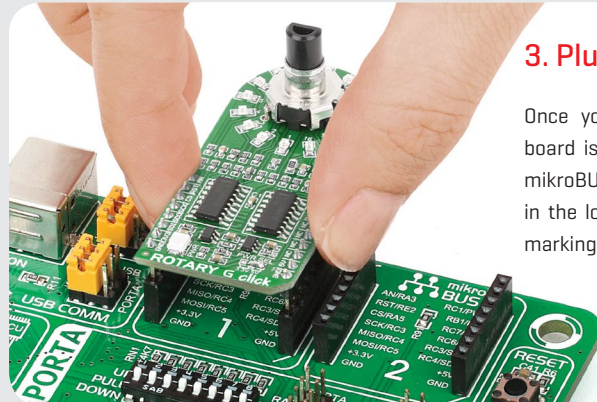

4. Essential features

Rotary G click™ with its LED ring is a perfect solution for implementing an input knob into your design [in contrast to a potentiometer, a rotary encoder can be spun round continuously]. A single rotation is divided into **15 discrete steps**. The encoder outputs A and B signals [out of phase to each other]. The knob is also a push-button outputted through the interrupt line. The LED ring are controlled through the SPI interface.

click™
BOARD

www.mikroe.com



ROTARY G click™ manual
ver 1.00



010000078105

5. Schematic

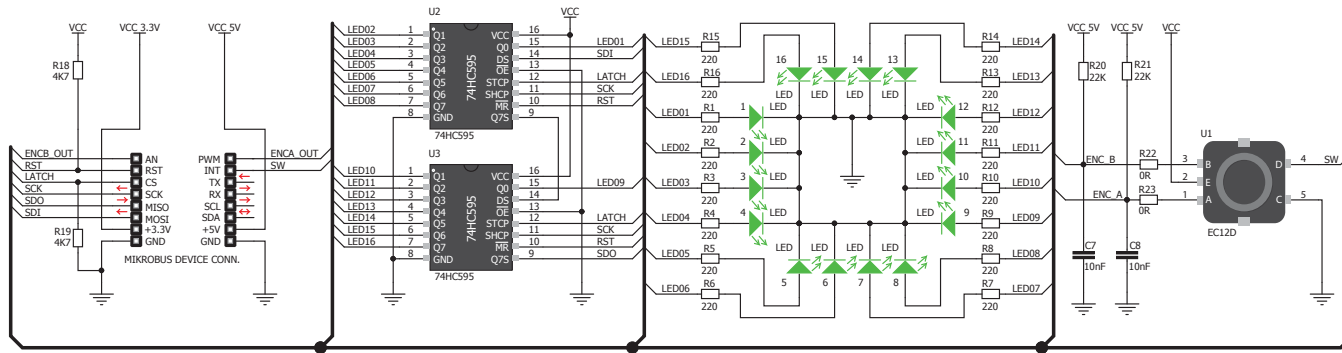
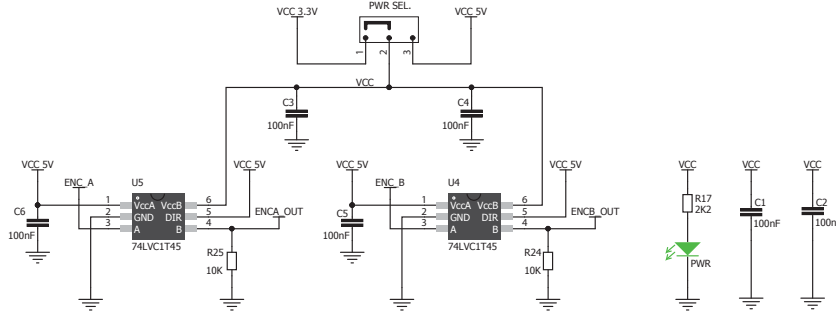

6. Dimensions

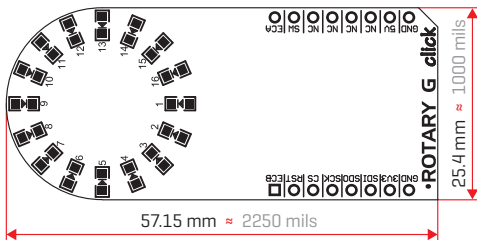

	mm	mils
LENGTH	57	2244
WIDTH	26	1024
HEIGHT	20	787

7. SMD jumper



There is one zero-ohm SMD jumper J1 used to select whether 3.3V or 5V I/O

voltage level is used. Jumper J1 is soldered in 3.3V position by default.

8. Code examples

Once you have done all the necessary preparations, it's time to get your click™ board up and running. We have provided examples for mikroC™, mikroBasic™ and mikroPascal™ compilers on our **Libstock** website. Just download them and you are ready to start.



9. Support

MikroElektronika assumes no responsibility or liability for any errors or inaccuracies that may appear in the present document. Specification and information contained in the present schematic are subject to change at any time without notice.

MikroElektronika offers **free tech support** [www.mikroe.com/support] until the end of the product's lifetime, so if something goes wrong, we're ready and willing to help!

Copyright © 2015 MikroElektronika.
All rights reserved.

