



Chipsmall Limited consists of a professional team with an average of over 10 year of expertise in the distribution of electronic components. Based in Hongkong, we have already established firm and mutual-benefit business relationships with customers from,Europe,America and south Asia,supplying obsolete and hard-to-find components to meet their specific needs.

With the principle of “Quality Parts,Customers Priority,Honest Operation,and Considerate Service”,our business mainly focus on the distribution of electronic components. Line cards we deal with include Microchip,ALPS,ROHM,Xilinx,Pulse,ON,Everlight and Freescale. Main products comprise IC,Modules,Potentiometer,IC Socket,Relay,Connector.Our parts cover such applications as commercial,industrial, and automotives areas.

We are looking forward to setting up business relationship with you and hope to provide you with the best service and solution. Let us make a better world for our industry!



Contact us

Tel: +86-755-8981 8866 Fax: +86-755-8427 6832

Email & Skype: info@chipsmall.com Web: www.chipsmall.com

Address: A1208, Overseas Decoration Building, #122 Zhenhua RD., Futian, Shenzhen, China



WiFi 7 click

PID: MIKROE-2046

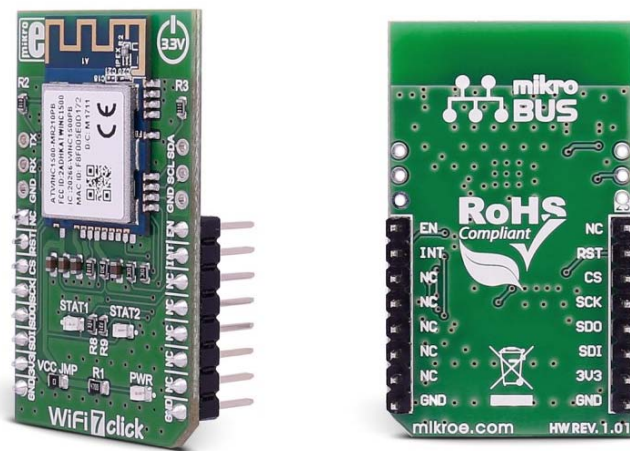

WiFi 7 click carries the ATWINC1510-MR210PB IEEE 802.11 b/g/n module, specifically optimized for low-power IoT applications. The click is designed to run on a 3.3V power supply. It communicates with the target microcontroller over SPI interface, with additional functionality provided by the following pins on the mikroBUS™ line: PWM, INT, RST.

ATWINC1510-MR210PB features

The ATWINC1510-MR210PB is a low-power consumption 802.11 b/g/n module which is specifically optimized for low-power IoT applications.

The module has a Cortus APS3 32-bit processor. This processor performs many of the MAC functions, including but not limited to association, authentication, power management, security key management, and MSDU aggregation/de-aggregation. In addition, the processor provides flexibility for various modes of operation, such as STA and AP modes.

Module current consumption

The table below describes the current consumption of the ATWINC1510-MR210PB module:

Device state	Code rate	Output power, dBm	Current consumption ⁽¹⁾	
			I _{BATT}	I _{VDDIO}
ON_Transmit	802.11b 1Mbps	19.5	294mA	22mA
	802.11b 11Mbps	20.5	290mA	22mA
	802.11g 6Mbps	19.5	292mA	22mA
	802.11g 54Mbps	17.5	250mA	22mA
	802.11n MCS 0	18.0	289mA	22mA
	802.11n MCS 7	15.5	244mA	22mA
ON_Receive	802.11b 1Mbps	N/A	52.5mA	22mA
	802.11b 11Mbps	N/A	52.5mA	22mA
	802.11g 6Mbps	N/A	55.0mA	22mA
	802.11g 54Mbps	N/A	57.5mA	22mA
	802.11n MCS 0	N/A	54.0mA	22mA
	802.11n MCS 7	N/A	58.5mA	22mA
ON_Doze	N/A	N/A	380µA	<10µA
Power_Down	N/A	N/A	<0.5µA	<3.5µA

Additional pins

Additional pins on the WiFi 7 click, besides the ones on the mikroBUS™ line:

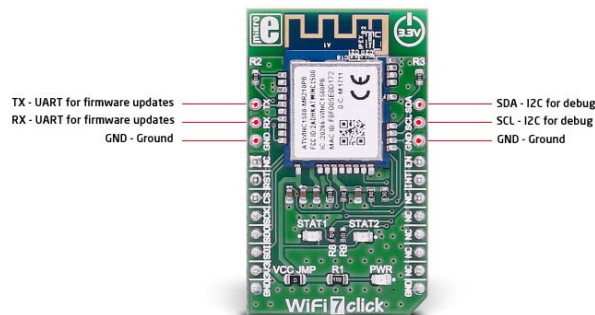

Key features

- ATWINC1510-MR210PB
 - IEEE® 802.11 b/g/n 20MHz solution
 - Integrated PCB antenna
 - Supports IEEE 802.11 WEP, WPA, WPA2 Security
- SPI interface
- 3.3V power supply

Specification

Type	Wi-Fi
Applications	Optimized for low power IoT applications
On-board modules	ATWINC1510-MR210PB
Key Features	IEEE® 802.11 b/g/n 20MHz solution, integrated PCB antenna, supports IEEE 802.11 WEP, WPA, WPA2 Security
Interface	SPI
Power Supply	3.3V
Compatibility	mikroBUS
Click board size	M (42.9 x 25.4 mm)

Pinout diagram

This table shows how the pinout on **WiFi 7 click** corresponds to the pinout on the mikroBUS™ socket (the latter shown in the two middle columns).

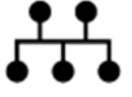
Notes	Pin	 mikroBUS™				Pin	Notes
Not connected	NC	1	AN	PWM	16	EN	Module Enable
Active-Low Hard Reset	RST	2	RST	INT	15	INT	Device Interrupt output
Chip select	CS	3	CS	TX	14	NC	Not connected
SPI Clock	SCK	4	SCK	RX	13	NC	Not connected
SPI Master Input Slave Output	MISO	5	MISO	SCL	12	NC	Not connected
SPI Master Output Slave Input	MOSI	6	MOSI	SDA	11	NC	Not connected
Power supply	+3.3V	7	3.3V	5V	10	NC	Not connected
Ground	GND	8	GND	GND	9	GND	Ground

Programming

Code examples for WiFi 7 click, written for MikroElektronika hardware and compilers are available on Libstock.

Code snippet

The following code snippet shows the default main function for all examples.

```
01 void main(void)
02 {
03     systemInit();
04     printf("Project built for Click Board\r\n");
05     printf("Starting driver initialization...\r\n");
06
07     hal_wifi7_init();
08     m2m_wifi_init();
09     while (1)
10     {
11         ApplicationTask();
12         m2m_wifi_task();
13     }
14 }
```