



Chipsmall Limited consists of a professional team with an average of over 10 year of expertise in the distribution of electronic components. Based in Hongkong, we have already established firm and mutual-benefit business relationships with customers from,Europe,America and south Asia,supplying obsolete and hard-to-find components to meet their specific needs.

With the principle of "Quality Parts,Customers Priority,Honest Operation,and Considerate Service",our business mainly focus on the distribution of electronic components. Line cards we deal with include Microchip,ALPS,ROHM,Xilinx,Pulse,ON,Everlight and Freescale. Main products comprise IC,Modules,Potentiometer,IC Socket,Relay,Connector.Our parts cover such applications as commercial,industrial, and automotives areas.

We are looking forward to setting up business relationship with you and hope to provide you with the best service and solution. Let us make a better world for our industry!



Contact us

Tel: +86-755-8981 8866 Fax: +86-755-8427 6832

Email & Skype: info@chipsmall.com Web: www.chipsmall.com

Address: A1208, Overseas Decoration Building, #122 Zhenhua RD., Futian, Shenzhen, China



PWM driver click

From MikroElektronika Documentation

If you need to control DC motors with loads up to 10A, **PWM driver click** is the perfect solution, thanks to the Silicon Lab Si8711CC one-channel isolator. It communicates with the target MCU over PWM pin, and runs on a 5V power supply. It can be used in a wide variety of ways, from controlling light intensity to serving as an ON/OFF switch to control DC load circuits.

Contents

- 1 Features and usage notes
 - 1.1 MOSFET transistor
 - 1.2 Onboard screw terminals
 - 1.3 Key features
- 2 Pinout diagram
- 3 Additional information about the click
- 4 Programming
- 5 Resources

Features and usage notes

MOSFET transistor

The click contains a P-channel DMP3010LK3 MOSFET transistor. When the click is used for PWM control it is not recommended to use it with loads of wattage over 50W because the MOSFET chip can get overheated. However, this does not apply when the click is used as an ON/OFF switch.

Onboard screw terminals

There are two pairs of screw terminals on the PWM driver click — one for the external power supply and one for the DC load.

Key features

- Si8711CC isolator from Silicon Labs
 - Data rates dc to 15 Mbps
 - 1 channel diode emulator input
- PWM pin interface
- Two pairs of screw terminals
- 5V power supply

Pinout diagram

This table shows how the pinout on PWM driver click corresponds to the pinout on the mikroBUS™ socket (the latter shown in the two middle columns).

Notes	Pin	 mikroBUS™		Pin	Notes		
	NC	1	AN	PWM	16	PWM	PWM or GPIO (ON/OFF) when used as a switch
	NC	2	RST	INT	15	NC	
	NC	3	CS	TX	14	NC	
	NC	4	SCK	RX	13	NC	
	NC	5	MISO	SCL	12	NC	
	NC	6	MOSI	SDA	11	NC	
<i>This click runs on 5V power supply only</i>	NC	7	+3.3V	+5V	10	+5V	Power supply
Ground	GND	8	GND	GND	9	GND	Ground

PWM driver click

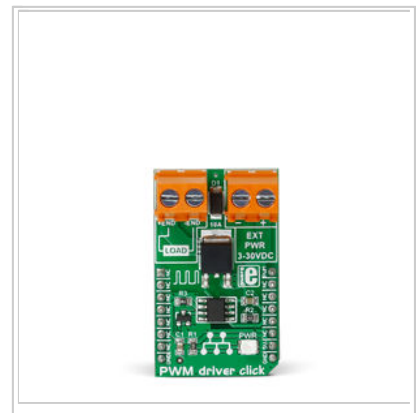

PWM driver click

IC/Module Si8711CC datasheet (<http://www.silabs.com/Support%20Documents/TechnicalDocs/Si87xx.pdf>)

Interface PWM

Power 5V

supply

Product www.mikroe.com/click/pwm-driver

page (<http://www.mikroe.com/click/pwm-driver/>)

Schematic PWM driver click schematic (http://cdn-docs.mikroe.com/images/c2/PWM_driver_click_schematic_v100.pdf)

Additional information about the click

There are two pairs of screw terminals on the PWM click. The table below shows their function.

Designator	Name	Type (LED, BUTTON...)	Description
LD1	PWR	LED	Power LED
CN1	EXTPWR	CONNECTOR	External power supply connection
CN2	LOAD	CONNECTOR	Load connection

Programming

This demo demonstrates the change of light intensity of a halogen lamp; using the on-board potentiometer P1 (EasyPIC 7), you can regulate the light intensity. For this demo we have used the EasyPIC v7 development system.

- Supply voltage within range of 3 – 30 V.
- Maximum output current detected: 15 mA.
- Wide operating temperature range: –40 to +125 °C
- Demo available for: ARM, PIC, PIC32, AVR and FTDI compilers.

This snippet shows the initialization of MCU (PWM and required port pins) and LCD. In an endless loop, we are reading current digitized value from ADC channel 1 and showing it's value with light intensity. Also, luminosity percentage is given on the LCD.

```

1 void main()
2 {
3     MCU_Init();           // Configure PORTB pins as digital
4     Lcd_Init();          // Initialize Lcd
5     Lcd_Display();       // Display text
6     current_duty = 0;
7     PWM2_Start();
8     PWM2_Set_Duty(current_duty);
9
10    while ( 1 )           // Playing with Potentiometer P1 you can control current PWM duty cycle
11    {                       // For visual result, look at LED PC1
12    {
13        uint8_t cur_duty_byte;
14
15        // Read 10 - bit ADC value and set newly acquired 8 - bit PWM duty
16        adc_rd = ADC_Read(1) & 0x0000FFFF;
17        current_duty = adc_rd / 4 ;
18        cur_duty_byte = LoWord(current_duty);
19        PWM2_Set_Duty(cur_duty_byte); // Set newly acquired duty
20        cur_duty_byte = cur_duty_byte * 0.39; // 100 / 256
21        ByteToStr(cur_duty_byte, txt);
22        Lcd_Out(2, 11, txt);
23        Delay_ms( 20 );
24    }
25 }

```

Resources

- PWM driver click schematic (http://cdn-docs.mikroe.com/images/c/c2/PWM_driver_click_schematic_v100.pdf)
- Si8711CC datasheet (<http://www.silabs.com/Support%20Documents/TechnicalDocs/Si87xx.pdf>)
- MOSFET datasheet (http://www.diodes.com/_files/datasheets/DMP3010LK3.pdf)
- mikroBUSTM standard specifications (<http://download.mikroe.com/documents/standards/mikrobus/mikrobus-standard-specification-v200.pdf>)

Retrieved from "http://docs.mikroe.com/index.php?title=PWM_driver_click&oldid=3136"

Category: Home page

- This page was last modified on 9 January 2017, at 14:09.
- Content is available under Creative Commons Attribution unless otherwise noted.