



Chipsmall Limited consists of a professional team with an average of over 10 year of expertise in the distribution of electronic components. Based in Hongkong, we have already established firm and mutual-benefit business relationships with customers from,Europe,America and south Asia,supplying obsolete and hard-to-find components to meet their specific needs.

With the principle of "Quality Parts,Customers Priority,Honest Operation,and Considerate Service",our business mainly focus on the distribution of electronic components. Line cards we deal with include Microchip,ALPS,ROHM,Xilinx,Pulse,ON,Everlight and Freescale. Main products comprise IC,Modules,Potentiometer,IC Socket,Relay,Connector.Our parts cover such applications as commercial,industrial, and automotives areas.

We are looking forward to setting up business relationship with you and hope to provide you with the best service and solution. Let us make a better world for our industry!



Contact us

Tel: +86-755-8981 8866 Fax: +86-755-8427 6832

Email & Skype: info@chipsmall.com Web: www.chipsmall.com

Address: A1208, Overseas Decoration Building, #122 Zhenhua RD., Futian, Shenzhen, China



GSM/GNSS click

PID: MIKROE-2439

Weight: 33 g

Condition: New product

GSM/GNSS click combines GPS/GLONASS location tracking with GSM module capability for mobile communication. The click features Quectel's MC60 **quad-band** module. GSM/GNSS click runs on either 3.3V or 5V power supply and communicates with the target MCU over UART interface, and the following mikroBUS™ pins: AN, RST, PWM, INT.



Table of contents

1. Quectel's MC60 quad-band module
2. Positioning — EASY™ technology
3. GPS and GLONASS
4. Application
5. Key features

GSM/GNSS click combines GPS/GLONASS location tracking with GSM module capability for mobile communication. The click features Quectel's [MC60 quad-band](#) module. GSM/GNSS click runs on either 3.3V or 5V power supply and communicates with the target MCU over UART interface, and the following mikroBUS™ pins: AN, RST, PWM, INT.

When connected to a **GPS antenna**, it can receive GPS coordinates, time, and other information from orbiting satellites. The click can be used for all GSM functions — calls, messages (SMS, MMS), mobile internet.

GSM/GNSS click has an onboard MicroSD card socket, micro SIM card socket, a Bluetooth antenna (the MC60 module supports Bluetooth 3.0) and additional pins for connecting speakers and a microphone.

Quectel's MC60 quad-band module

MC60 is a quad-band full-featured GSM/GPRS module using LCC castellation package. With an extensive set of internet protocols (TCP, UDP, PPP, FTP, HTTP and SSL*), it has integrated GNSS technology for satellite navigation.

The module can balance between positioning accuracy and power consumption according to the environmental and motion conditions. The typical power consumption is around 2.8mA.

Positioning — EASY™ technology

EASY™ is the abbreviation of Embedded Assist System for quick positioning. With EASY™ technology, MC60's GNSS engine can automatically calculate and predict orbits using the ephemeris data (up to 3 days) when the power is on, and then save that information into the memory.

The GNSS engine can use this information for later positioning, if there is not enough information from the satellites.

GPS and GLONASS

GNSS stands for Global Navigation Satellite System, an umbrella term that describes both the United States GPS and the Russian GLONASS global positioning systems. GLONASS is an acronym for Globalnaya Navigatsionnaya Sputnikovaya Sistema (Global Navigation Satellite System).

GPS currently has 33 satellites in orbit, and GLONASS has 24. This two-constellation system is particularly suitable for urban areas with high-rise buildings and complex environments.

GLONASS is suited for usage in high latitudes (north or south), where getting a GPS signal can be difficult.

Application

Asset tracking, for navigation devices based on GPS and GLONASS, road navigation devices, public transport, wearable devices, etc.

Key features

- MC60 module
 - Multi navigation constellation: GPS/GLONASS/QZSS
 - GNSS receiver channels: 99 acquisition/33 tracking channels
 - GSM quad-band: 850/900/1800/1900MHz
 - Support Bluetooth V3.0: SPP & HFP-AG profiles
- GSM SMA antenna connector
- GNSS SMA antenna connector
- Bluetooth antenna
- Interface: UART
- 3.3V or 5V power supply

SPECIFICATION

Product Type	GSM - GPS
Applications	Asset tracking, for navigation devices based on GPS and GLONASS, road navigation devices, public transport, wearable devices, etc.
Key Features	MC60 quad-band module, GPS/GNSS location tracking, UART interface, 3.3V or 5V power supply
Key Benefits	GPS, GNSS, GSM, and Bluetooth in one click
Interface	UART
Power Supply	3.3V or 5V
Compatibility	mikroBUS
Click board size	L (57.15 x 25.4 mm)

Pinout diagram

This table shows how the pinout on **GSM/GNSS click** corresponds to the pinout on the mikroBUS™ socket (the latter shown in the two middle columns).

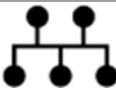
Notes	Pin	 mikroBUS™				Pin	Notes
SD card detect	DET	1	AN	PWM	16	RING	Ring indicator
Reset	RST	2	RST	INT	15	CTS	Clear to send
Ready to send	RTS	3	CS	RX	14	RXD	UART Receive
Not connected	NC	4	SCK	TX	13	TXD	UART Transmit
Not connected	NC	5	MISO	SCL	12	NC	Not connected
Not connected	NC	6	MOSI	SDA	11	NC	Not connected
Power supply	+3.3V	7	3.3V	5V	10	+5V	Power supply
Ground	GND	8	GND	GND	9	GND	Ground

Programming

- Notes on the demo/library

The demo initialises and configures GSM/GNSS click and waits for a new message to arrive. When the message is received, the text and the number of the sender are shown on the display. In the initialisation procedure, it waits for the SIM card to be ready. When the SIM card is ready, it runs the AT process and waits for the URC message from ME. The +CMT message signalises that the message is received.

The demo uses the AT engine library for communication with GSM/GNSS module.

The demo doesn't use default autobauding, instead the module is externally configured to 9600 bps with AT+IPR command and AT&W command to store current parameters to the user defined profile.

To provide the needed current level the external power supply is used on the EasyAVR v7 development board.

- Hexiwear example

The Hexiwear example has predefined messages which can be selected and sent. Also, the example uses GNSS module to acquire location from where the message is being sent. The location is appended at the end of every message in the form of a Google map link.

Code snippet

The code snippet shows minimal initialisation code to work with GSM/GNSS click and AT engine.

```
01: static void system_init( void )
02: {
03:     // Set RST pin as output.
04:     GPIO_Digital_Output( &GPIOC_ODR, _GPIO_PINMASK_2 );
05:
06:     UART3_Init_Advanced(
07:         GSM_GNSS_MODEM_BAUD_RATE,
08:         _UART_8_BIT_DATA,
09:         _UART_NOPARITY,
10:         _UART_ONE_STOPBIT,
11:         &GPIO_MODULE_USART3_PD89
12:     );
13:
14:     // Timer initialisation. Timer is used by AT engine.
15:     RCC_APB1ENR.TIM2EN = 1;
16:     TIM2_CR1.CEN = 0;
17:     TIM2_PSC = 1;
18:     TIM2_ARR = 35999;
19:     NVIC_IntEnable(IVT_INT_TIM2);
20:     TIM2_DIER.UIE = 1;
21:     TIM2_CR1.CEN = 1;
22:
23:     // UART interrupt initialisation.
24:     RXNEIE_USART3_CR1_bit = 1;
25:     NVIC_IntEnable( IVT_INT_USART3 );
26:
27:     EnableInterrupts();
28:
29:     at_init(
30:         gsm_gnss_click_default_event,
31:         UART3_Write,
32:         at_buffer,
33:         AT_BUFFER_SIZE
34:     );
35: }
```