



Chipsmall Limited consists of a professional team with an average of over 10 year of expertise in the distribution of electronic components. Based in Hongkong, we have already established firm and mutual-benefit business relationships with customers from,Europe,America and south Asia,supplying obsolete and hard-to-find components to meet their specific needs.

With the principle of “Quality Parts,Customers Priority,Honest Operation,and Considerate Service”,our business mainly focus on the distribution of electronic components. Line cards we deal with include Microchip,ALPS,ROHM,Xilinx,Pulse,ON,Everlight and Freescale. Main products comprise IC,Modules,Potentiometer,IC Socket,Relay,Connector.Our parts cover such applications as commercial,industrial, and automotives areas.

We are looking forward to setting up business relationship with you and hope to provide you with the best service and solution. Let us make a better world for our industry!



Contact us

Tel: +86-755-8981 8866 Fax: +86-755-8427 6832

Email & Skype: info@chipsmall.com Web: www.chipsmall.com

Address: A1208, Overseas Decoration Building, #122 Zhenhua RD., Futian, Shenzhen, China



Grid-EYE click

PID: MIKROE-2539

Weight: 30 g



Grid-EYE click is a 8x8 thermal array sensor-detector that carries the AMG8853 **infrared array sensor from Panasonic**. The click is designed to run on either 3.3V or 5V power supply. It communicates with the target MCU over I2C interface.

Use the Grid-EYE click to detect absolute surface temperature without any contact. Or use it to detect the movement of people and objects.

Take a look at how Panasonic's AMG8853 64 thermal sensors see a moving hand:

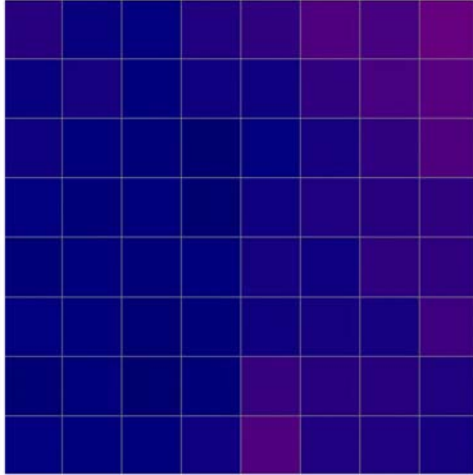

AMG8853 sensor features

The AMG8853 is made out of **64 individual thermal sensors**. It can build an image according to the heat it detects. You don't need light to form a picture.

The temperature measuring range is from **-20°C to +100°C**.

The detecting distance is **5m**, the viewing angle 60 degrees.

The AMG8853 has a built-in thermistor for suppressing ambient temperature noise.

The I2C levels and address are jumper selectable, while the AMG8853 is supplied with designated voltage.

Infrared sensor

Infrared waves are outside the visible spectrum of the human eye, just like radio waves. Even though people can't see infrared waves, they can certainly feel them, in the form of heat.

Our bodies emit heat or infrared radiation, and the AMG8853 thermal array sensor can detect it.

Key features

- AMG8853 infrared array sensor
 - 5m detecting distance
 - 60 degrees viewing angle
 - 0.25°C temperature resolution
 - Typical current consumption: 4.5mA
 - Time to stabilize the output: 15 seconds
 - Frame rate: 1f/sec or 10f/sec
- I2C interface
- 3.3V or 5V power supply

Product Type	Temperature / Humidity
Applications	Thermal imaging systems, detecting movement of people and objects, etc
MCU	AMG8853 thermal array sensor from Panasonic
Key Features	5 m detecting distance, 60 degrees viewing angle, 64 individual thermal sensors
Key Benefits	Detect absolute surface temperature without any contact
Interface	I2C
Power Supply	3.3V or 5V
Compatibility	mikroBUS
Click board size	M (42.9 x 25.4 mm)

Pinout diagram

This table shows how the pinout on **Grid-EYE click** corresponds to the pinout on the mikroBUS™ socket (the latter shown in the two middle columns).

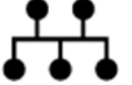
Notes	Pin	 mikroBUS™				Pin	Notes
Not connected	NC	1	AN	PWM	16	NC	Not connected
Not connected	NC	2	RST	INT	15	INT	INT out to MCU
Not connected	NC	3	CS	TX	14	NC	Not connected
Not connected	NC	4	SCK	RX	13	NC	Not connected
Not connected	NC	5	MISO	SCL	12	SCL	I2C SCK
Not connected	NC	6	MOSI	SDA	11	SDA	I2C data
Power supply	+3.3V	7	3.3V	5V	10	+5V	Power supply
Ground	GND	8	GND	GND	9	GND	Ground

Jumpers and settings

Designator	Name	Default Position	Default Option	Description
JP1	LOGIC SEL	Left	3.3V	Logic Level Voltage Selection, left position 3.3V, right position 5V
JP2	ADDR SEL	Right	0	I2C address selection, right 0 (0b1101 000) Left 1 (0b1101 001)

Buttons and LEDs

Designator	Name	Type (LED, BUTTON...)	Description
PWR	Power	LED	Power supply LED, lights green when power is on.

Maximum ratings

Description	Min	Typ	Max	Unit
Supply Voltage (with AMG8853 module)	5		5	V
I2C Levels (JP1 select)	0		5	V
INT out (JP1 select)	0		5	V

Programming

Code examples for Grid-EYE click, written for MikroElektronika hardware and compilers are available on Libstock.

Code snippet

This code converts the grid array sensor data to temperature [in C] and fills the grid array drawn on the TFT display by the appropriate color, depending on the temperature detected.

```
01 void main() {
02     // Initialize pins as digital I/O
03     AD1PCFG = 0xFFFF;
04     JTAGEN_bit = 0;
05
06     // Initialize I2C2 module
07     I2C2_Init(100000);
08     Delay_ms(100);
```

```

09
10 // Draw screen
11 DrawScreen();
12
13 // variable declaration
14 x_start = 80;
15 element_dimension = 20;
16 j = 0;
17
18 // Set AMG88 sensor registers
19 GridEye_WriteByte(0x00, 0x00); // Normal mode
20 GridEye_WriteByte(0x01, 0x30); // Flag reset
21 GridEye_WriteByte(0x02, 0x00); // Frame mode 10FPS
22 Delay_ms(100); // small delay
23
24 GridEye_WriteByte(0x08, 0x30); // INTHL
25 GridEye_WriteByte(0x09, 0x00); // INTHH
26
27 GridEye_WriteByte(0x0A, 0x15); // INTLL
28 GridEye_WriteByte(0x0B, 0x00); // INTLH
29
30 GridEye_WriteByte(0x0C, 0x20); // IHYSL
31 GridEye_WriteByte(0x0D, 0x00); // IHYSH
32 Delay_ms(100); // small delay
33
34 // Temperature register value
35 register_address = 0x80;
36
37 while(1) {
38 // Reading grid temperature
39 for(i = 0; i < 64; i++) {
40 // multiply the values with 0.25 to get temperature in [C]
41 gridArray[i] = (float)GridEye_ReadWord(register_address) * 0.25L;
42 // increment register address by 2
43 register_address = register_address + 2;
44 }
45
46 // draw grid
47 for(i = 0; i < 64; i++) {
48 // set row position
49 Set_Row_Position();
50
51 // set color
52 color = Set_Color();
53

```

```
54 // set grid element number
55 j++;
56
57 // fill grid element with color
58 TFT_Set_Brush(1, 0, 1, LEFT_TO_RIGHT, color, color);
59
60 // draw grid element
61 TFT_Rectangle(x_start + (element_dimension * (j - 1)), y_start ,
x_start + (element_dimension * j), y_end);
62
63 // if more than 8 elements in the row, reset counter
64 if (j >= 8) {
65     j = 0;
66 }
67 }
68 }
69 }
```