



Chipsmall Limited consists of a professional team with an average of over 10 year of expertise in the distribution of electronic components. Based in Hongkong, we have already established firm and mutual-benefit business relationships with customers from,Europe,America and south Asia,supplying obsolete and hard-to-find components to meet their specific needs.

With the principle of “Quality Parts,Customers Priority,Honest Operation,and Considerate Service”,our business mainly focus on the distribution of electronic components. Line cards we deal with include Microchip,ALPS,ROHM,Xilinx,Pulse,ON,Everlight and Freescale. Main products comprise IC,Modules,Potentiometer,IC Socket,Relay,Connector.Our parts cover such applications as commercial,industrial, and automotives areas.

We are looking forward to setting up business relationship with you and hope to provide you with the best service and solution. Let us make a better world for our industry!



Contact us

Tel: +86-755-8981 8866 Fax: +86-755-8427 6832

Email & Skype: info@chipsmall.com Web: www.chipsmall.com

Address: A1208, Overseas Decoration Building, #122 Zhenhua RD., Futian, Shenzhen, China



MCP73213 click

PID: MIKROE-2575



MCP73213 click carries the MCP73213 dual-cell Li-Ion/Li-Polymer battery charge management controller with input overvoltage protection from Microchip. The click is designed to run on either 3.3V or 5V power supply. It communicates with the target microcontroller over SPI.

Note: The click is designed to charge a dual-cell Li-Ion/Li-Polymer battery. The input voltage needs to be higher than the voltage of a dual-cell Li-Ion/Li-Polymer battery.

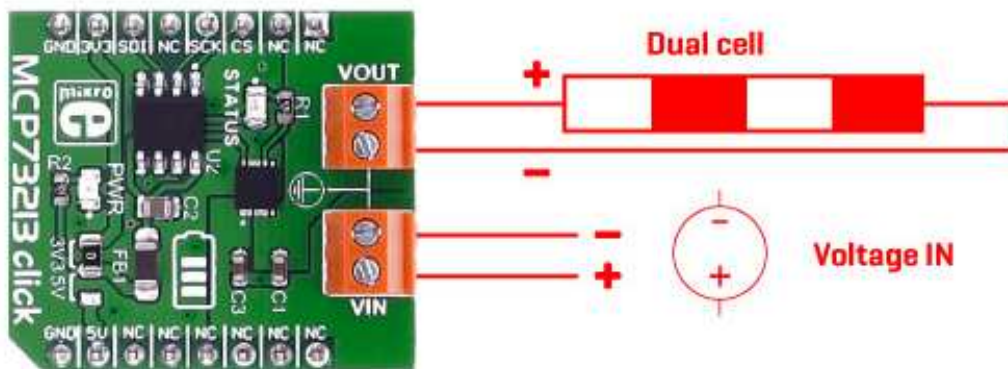

MCP73213 controller features

The MCP73213 is a highly integrated Li-Ion battery charge management controller.

The MCP73213 provides specific charge algorithms for dual-cell Li-Ion/Li-Polymer batteries to achieve optimal capacity and safety in the shortest charging time possible.

The absolute maximum voltage, up to 18V, allows the use of MCP73213 in harsh environments, such as low-cost wall wart or voltage spikes from plug/unplug.

An internal **overvoltage protection** (OVP) circuit monitors the input voltage and keeps the charger in shutdown mode when the input supply rises above the typical 13V OVP threshold. The OVP hysteresis is approximately 150 mV for the MCP73213 device.

How it works

First you need to connect the input voltage to the input screw terminal. Then to set the input voltage, because it needs to be larger than voltage of two series connected batteries for regular charging, (which means it needs to be >8V). We can change the charging current trough SPI interface.

Now just leave the batteries to charge, and when they are charged it will be signaled on the status LED.

Key features

- MCP73213 controller
 - 13V Input Overvoltage Protection
 - Resistor Programmable Fast Charge Current: 130 mA-1100 mA
 - Elapse Safety Timer: 4 hr, 6 hr, 8 hr or Disable
- Two pairs of screw terminals
- Status indication LED
- SPI interface
- 3.3V or 5V power supply

Specification

Product Type	Buck
Applications	Portable Media players, digital camcorders, handheld devices, etc.
MCU	MCP73213
Key Features	13V Input Overvoltage Protection, Resistor Programmable Fast Charge Current: 130 mA-1100 mA, Elapse Safety Timer: 4 hr, 6 hr, 8 hr or Disable
Interface	SPI
Power Supply	3.3V or 5V

Compatibility	mikroBUS
Click board size	S (28.6 x 25.4 mm)

Pinout diagram

This table shows how the pinout on **MCP73213 click** corresponds to the pinout on the mikroBUS™ socket (the latter shown in the two middle columns).

Notes	Pin	 mikroBUS™				Pin	Notes
Not connected	NC	1	AN	PWM	16	NC	Not connected
Not connected	NC	2	RST	INT	15	NC	Not connected
Chip Select	SPI_CS	3	CS	TX	14	NC	Not connected
SPI Clock	SPI_SCK	4	SCK	RX	13	NC	Not connected
Not connected	NC	5	MISO	SCL	12	NC	Not connected
SPI Master output slave input	SPI_MOSI	6	MOSI	SDA	11	NC	Not connected
Power supply	+3.3V	7	3.3V	5V	10	+5V	Power supply
Ground	GND	8	GND	GND	9	GND	Ground

Maximum ratings

Description	Min	Typ	Max	Unit
Input Voltage Range	4		16	V
Operating Supply Voltage	4.2		13	V
Fast Change Current Regulation	130		1100	A

Programming

Code examples for MCP73213 click, written for MikroElektronika hardware and compilers are available on [Libstock](#).

Code snippet

The following code snippet shows how to initialize the SPI interface, and then use it to set output current to 250mA.

```
01 void main() {
02
03     /*Sets chip select*/
04     GPIO_Digital_Output (&GPIOD_BASE, _GPIO_PINMASK_13);
05
06     GPIO_Alternate_Function_Enable(&_GPIO_MODULE_SPI3_PC10_11_12);
07     /*Initializes SPI interface*/
08     SPI3_Init_Advanced(_SPI_FPCLK_DIV256, _SPI_MASTER | _SPI_16_BIT |
09         _SPI_CLK_IDLE_LOW | _SPI_FIRST_CLK_EDGE_TRANSITION | _SPI_MSB_FIRST
10         |
11         _SPI_SS_DISABLE | _SPI_SSM_ENABLE | _SPI_SSI_1,
12         &_GPIO_MODULE_SPI3_PC10_11_12);
13
14     SPI_Set_Active(SPI3_Read, SPI3_Write);
15     /*Sets chip select to inactive*/
16     GPIOD_ODR.B13 = 1;
17
18     delay_ms(5000);
19
20
21     //5 kOhm, 250mA
22     GPIOD_ODR.B13 = 0;
23     Spi3_Write(0b00000000);
24     Spi3_Write(0b10000010);
25     GPIOD_ODR.B13 = 1;
26     delay_ms(5000);
27 }
```