



Chipsmall Limited consists of a professional team with an average of over 10 year of expertise in the distribution of electronic components. Based in Hongkong, we have already established firm and mutual-benefit business relationships with customers from,Europe,America and south Asia,supplying obsolete and hard-to-find components to meet their specific needs.

With the principle of “Quality Parts,Customers Priority,Honest Operation,and Considerate Service”,our business mainly focus on the distribution of electronic components. Line cards we deal with include Microchip,ALPS,ROHM,Xilinx,Pulse,ON,Everlight and Freescale. Main products comprise IC,Modules,Potentiometer,IC Socket,Relay,Connector.Our parts cover such applications as commercial,industrial, and automotives areas.

We are looking forward to setting up business relationship with you and hope to provide you with the best service and solution. Let us make a better world for our industry!



Contact us

Tel: +86-755-8981 8866 Fax: +86-755-8427 6832

Email & Skype: info@chipsmall.com Web: www.chipsmall.com

Address: A1208, Overseas Decoration Building, #122 Zhenhua RD., Futian, Shenzhen, China



Boost 4 click

PID: MIKROE-2757



Boost 4 click carries the TPS61230A, a high efficiency fully integrated synchronous boost converter from Texas Instruments. The click is designed to run on a 3.3V power supply. Boost 4 click drives the target chip through the digi pot, which has SPI communication with the microcontroller on the system.

Boost 4 click is the power management solution for your next project.

How the click works

Boost 4 click provides an adjustable output voltage through the SPI DAC, that drives the FB pin to set desired voltage. The click is capable of delivering up to **2.4-A output current** at a 5V output with the 2.5-V input supply.

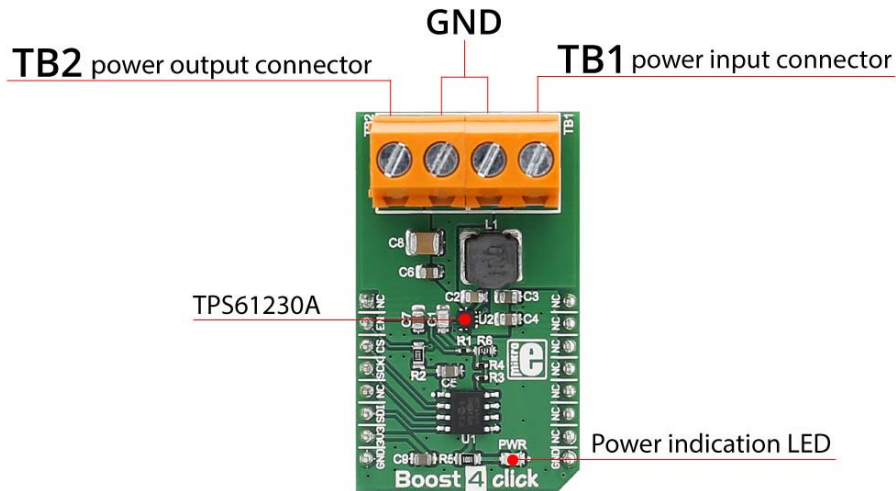

TPS61230A features

The TPS61230A device is a high efficiency fully integrated synchronous boost converter. It integrates 6-A, 21-mΩ and 18-mΩ power switches.

During the light load condition, the TPS61230A automatically enters into the PFM operation for maximizing the efficiency with the lowest quiescent current. In the shutdown by pulling EN pin to the logic low, the load is completely disconnected from the input, and the input current consumption is reduced to below 1.0 μA.

Specifications

Type	Boost
Applications	Battery powered products, battery backup units, etc.
On-board modules	TPS61230A, a high efficiency fully integrated synchronous boost converter from Texas Instruments
Key Features	Input Voltage Range: 2.5 V to 4.5 V, output Voltage Range: 2.5 V to 5.5 V
Interface	SPI
Input Voltage	3.3V
Click board size	M (42.9 x 25.4 mm)

Pinout diagram

This table shows how the pinout on **Boost 4 click** corresponds to the pinout on the mikroBUS™ socket (the latter shown in the two middle columns).

Notes	Pin					Pin	Notes
	NC	1	AN	PWM	16	NC	
Enable pin	EN	2	RST	INT	15	NC	
Chip select	CS	3	CS	TX	14	NC	
SPI clock	SCK	4	SCK	RX	13	NC	
	SDO	5	MISO	SCL	12	NC	
Slave data in for SPI	SDI	6	MOSI	SDA	11	NC	
	NC	7	3.3V	5V	10	NC	
Ground	GND	8	GND	GND	9	GND	Ground

Programming

Code examples for Boost 4 click, written for MikroElektronika hardware and compilers are available on Libstock.

Code snippet

The following code snippet shows how to cycle through different output voltages.

```
01 void main()
02 {
03     systemInit();
04
05     while (1)
06     {
07         delay_ms(3000);
08         //Sets the voltage to VOUTmax, ~5.25 V
09         CS_PIN = 0;           //Sets chip select to active
10         Spi3_Write(0b01110000);
```

```

11     Spi3_Write(0b00000000);
12     CS_PIN = 1;           //Sets chip select to inactive
13
14     delay_ms(3000);
15     //Sets the voltage to VOUTmin, which depends on VIN, but cannot
16     //be lower than 2.50 V
17     CS_PIN = 0;           //Sets chip select to active
18     Spi3_Write(0b01111111);
19     Spi3_Write(0b11111111);
20     CS_PIN = 1;           //Sets chip select to inactive
21
22     delay_ms(3000);
23     //Sets the voltage ~4.0 V
24     CS_PIN = 0;           //Sets chip select to active
25     Spi3_Write(0b01110111);
26     Spi3_Write(0b01000000);
27     CS_PIN = 1;           //Sets chip select to inactive
28
29     delay_ms(3000);
30     //Sets the voltage ~4.5 V
31     CS_PIN = 0;           //Sets chip select to active
32     Spi3_Write(0b01110100);
33     Spi3_Write(0b00011111);
34     CS_PIN = 1;           //Sets chip select to inactive
35 }
36 }

```