



Chipsmall Limited consists of a professional team with an average of over 10 year of expertise in the distribution of electronic components. Based in Hongkong, we have already established firm and mutual-benefit business relationships with customers from,Europe,America and south Asia,supplying obsolete and hard-to-find components to meet their specific needs.

With the principle of “Quality Parts,Customers Priority,Honest Operation,and Considerate Service”,our business mainly focus on the distribution of electronic components. Line cards we deal with include Microchip,ALPS,ROHM,Xilinx,Pulse,ON,Everlight and Freescale. Main products comprise IC,Modules,Potentiometer,IC Socket,Relay,Connector.Our parts cover such applications as commercial,industrial, and automotives areas.

We are looking forward to setting up business relationship with you and hope to provide you with the best service and solution. Let us make a better world for our industry!



Contact us

Tel: +86-755-8981 8866 Fax: +86-755-8427 6832

Email & Skype: info@chipsmall.com Web: www.chipsmall.com

Address: A1208, Overseas Decoration Building, #122 Zhenhua RD., Futian, Shenzhen, China



MCU Cards

for **BIGdsPIC6™** development system

Manual

All Mikroelektronika's development systems feature a large number of peripheral modules expanding microcontroller's range of application and making the process of program testing easier. In addition to these modules, it is also possible to use numerous additional modules linked to the development system through the I/O port connectors. Some of these additional modules can operate as stand-alone devices without being connected to the microcontroller.

Additional Board

 **MikroElektronika**

SOFTWARE AND HARDWARE SOLUTIONS FOR EMBEDDED WORLD ...making it simple

MCU Cards for BIGdsPIC6 Development System

The BIGdsPIC6 development system is supported by empty 64- and 80-pin MCU cards. Schematics provided herein show these MCU cards with soldered microcontrollers. Instead of microcontrollers used in these examples, you can choose and solder another ones. Prior to soldering, check which microcontrollers can be placed on the respective MCU card just to be sure that they are compatible. MCU cards are also provided with pads that enables you to access microcontroller pins when the MCU card is not connected to the development system.

Supported microcontrollers:

64-pin MCU cards support the following microcontrollers: U1: dsPIC30F6012A-PT, dsPIC30F6011A-PT and dsPIC30F5011-PT; U2: dsPIC30F5015-PT and dsPIC30F6015-PT.

80-pin MCU cards support the following microcontrollers in TQFP1 package: dsPIC30F6014A-PT, dsPIC30F6013A-PT and dsPIC30F5013-PT.

80-pin MCU cards support the following microcontrollers in TQFP2 package: dsPIC30F5016-PT and dsPIC30F6010A-PT.

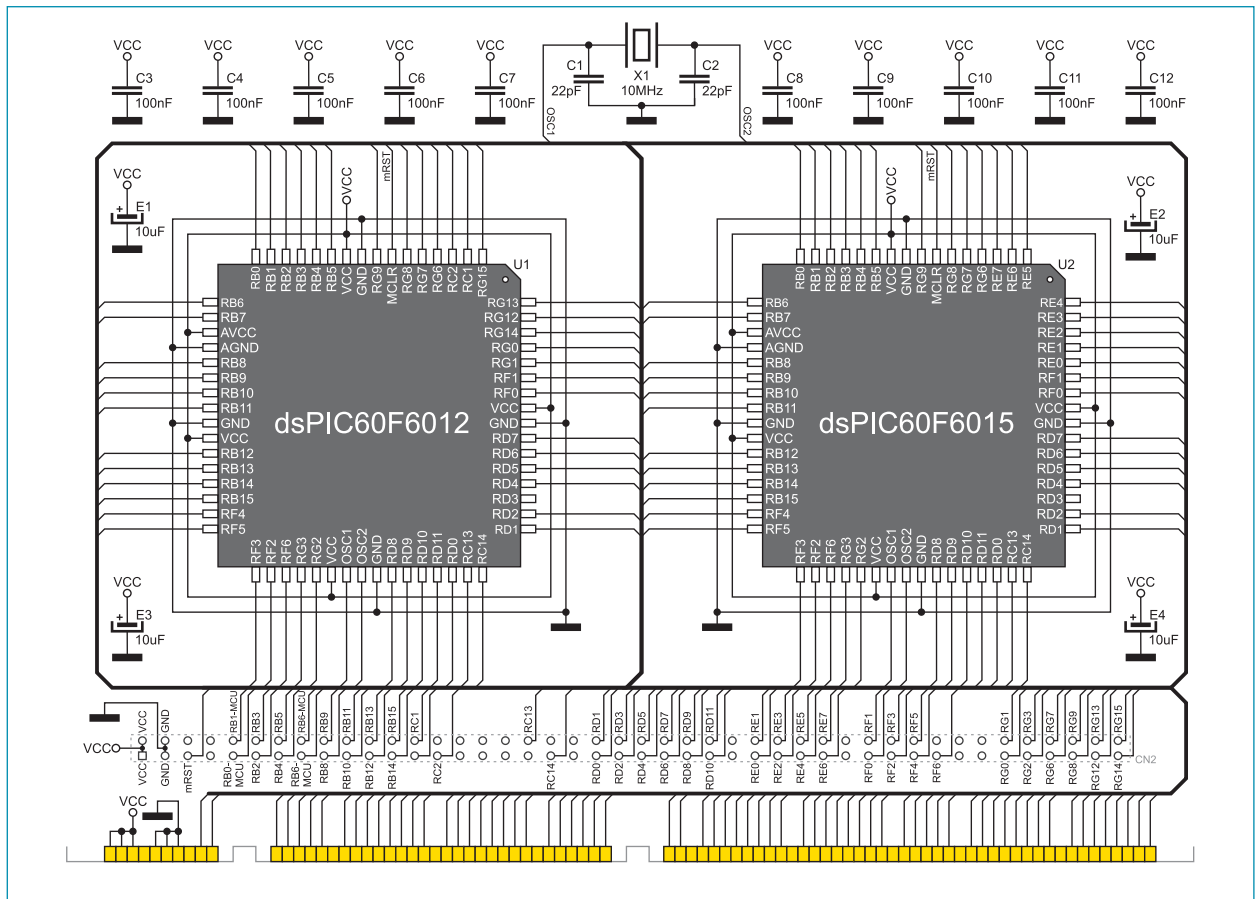

Figure 1: 64-pin MCU card and microcontroller connection schematic

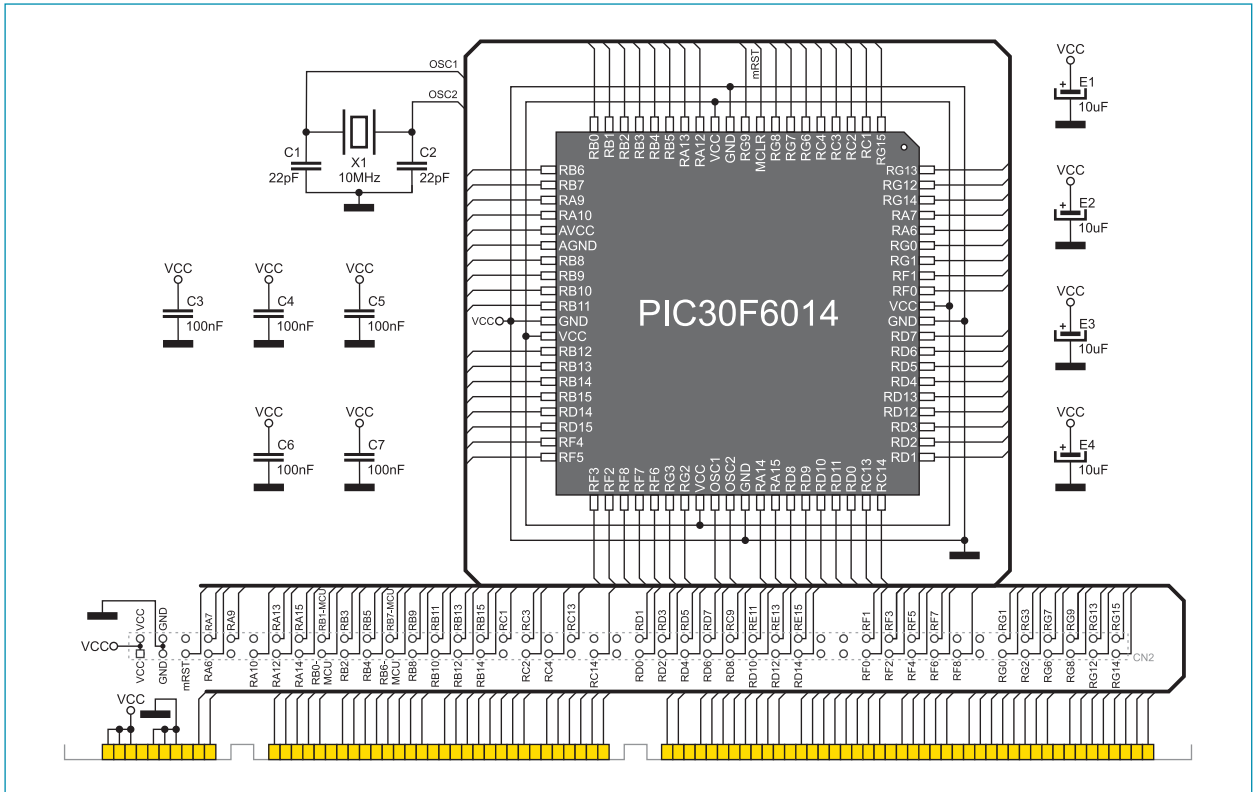

Figure 2: 80-pin MCU card and microcontroller connection schematic (TQFP1)

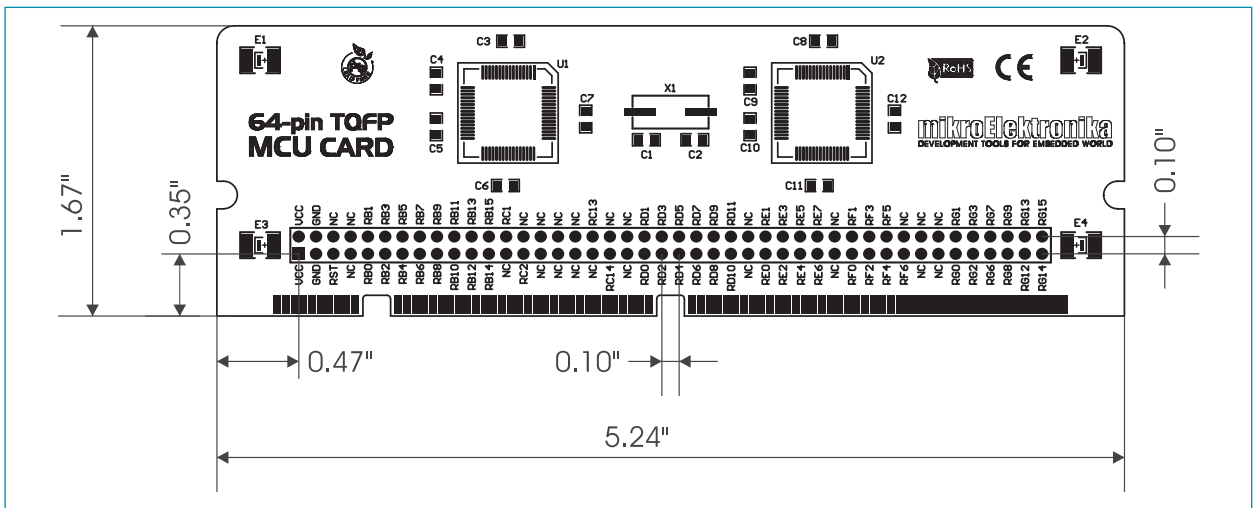

Figure 3: Dimensions of MCU card for BIGDsPIC6

NOTE: 64- and 80-pin MCU cards have the same dimensions.

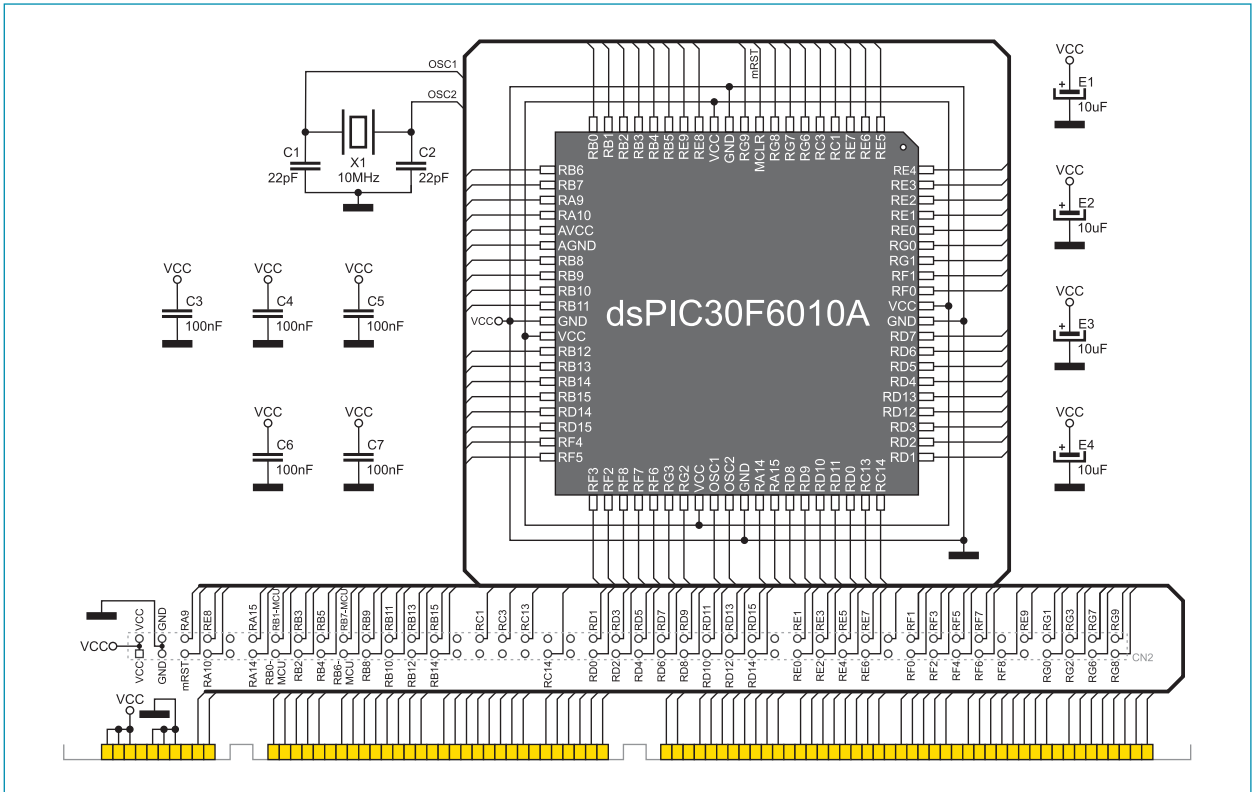

Figure 4: 80-pin MCU card and microcontroller connection schematic (TQFP2)

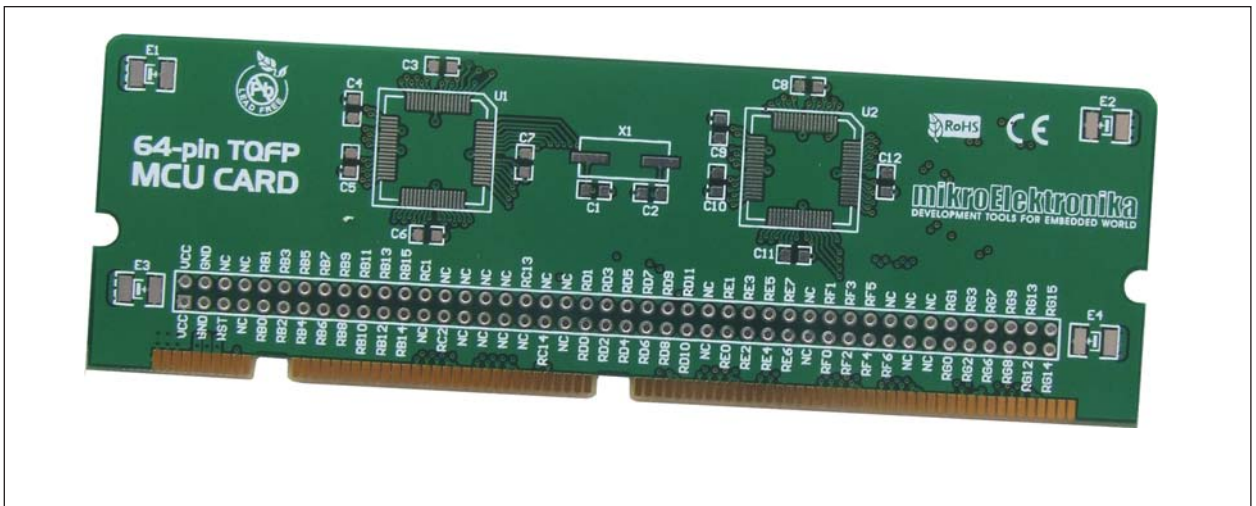

Figure 5: Empty 64-pin MCU card

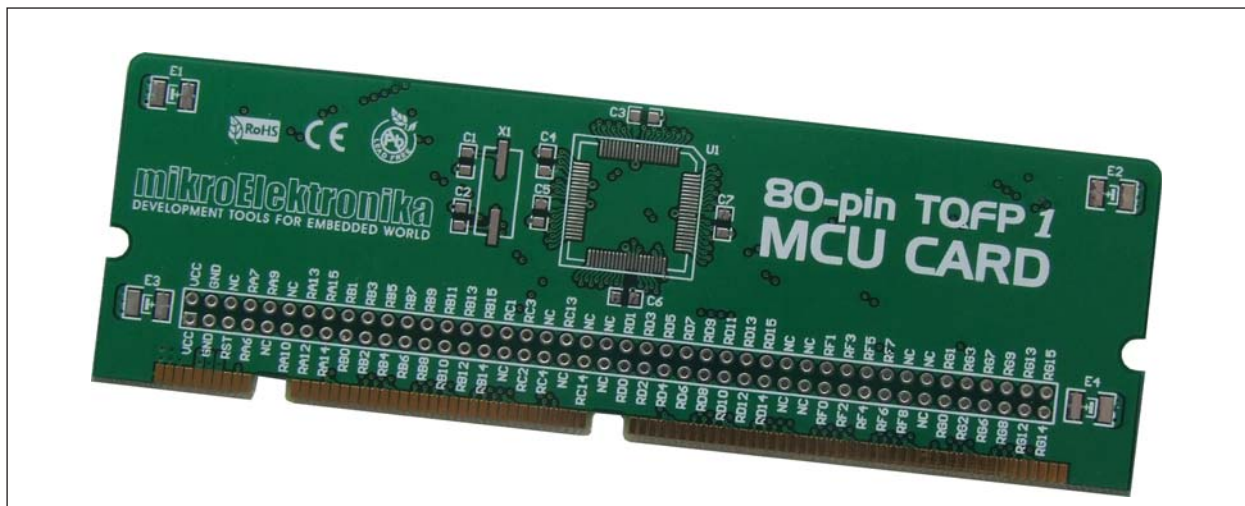

Figure 6: Empty 64-pin MCU card (TQFP1)



Figure 7: Empty 80-pin MCU card (TQFP2)

If you want to learn more about our products, please visit our website at www.mikroe.com

If you are experiencing some problems with any of our products or just need additional information, please place your ticket at www.mikroe.com/en/support

If you have any questions, comments or business proposals, do not hesitate to contact us at office@mikroe.com