



Chipsmall Limited consists of a professional team with an average of over 10 year of expertise in the distribution of electronic components. Based in Hongkong, we have already established firm and mutual-benefit business relationships with customers from,Europe,America and south Asia,supplying obsolete and hard-to-find components to meet their specific needs.

With the principle of “Quality Parts,Customers Priority,Honest Operation,and Considerate Service”,our business mainly focus on the distribution of electronic components. Line cards we deal with include Microchip,ALPS,ROHM,Xilinx,Pulse,ON,Everlight and Freescale. Main products comprise IC,Modules,Potentiometer,IC Socket,Relay,Connector.Our parts cover such applications as commercial,industrial, and automotives areas.

We are looking forward to setting up business relationship with you and hope to provide you with the best service and solution. Let us make a better world for our industry!



Contact us

Tel: +86-755-8981 8866 Fax: +86-755-8427 6832

Email & Skype: info@chipsmall.com Web: www.chipsmall.com

Address: A1208, Overseas Decoration Building, #122 Zhenhua RD., Futian, Shenzhen, China



EasyLEDTM

Manual

All Mikroelektronika's development systems feature a large number of peripheral modules expanding microcontroller's range of application and making the process of program testing easier. In addition to these modules, it is also possible to use numerous additional modules linked to the development system through the I/O port connectors. Some of these additional modules can operate as stand-alone devices without being connected to the microcontroller.

Additional board

 **MikroElektronika**

SOFTWARE AND HARDWARE SOLUTIONS FOR EMBEDDED WORLD ...making it simple

EasyLED

The EasyLED additional board is used to connect a development system port to LEDs.

Key features:

- Parallel communication;
- 8 LEDs;
- 3.3V or 5V power supply voltage.

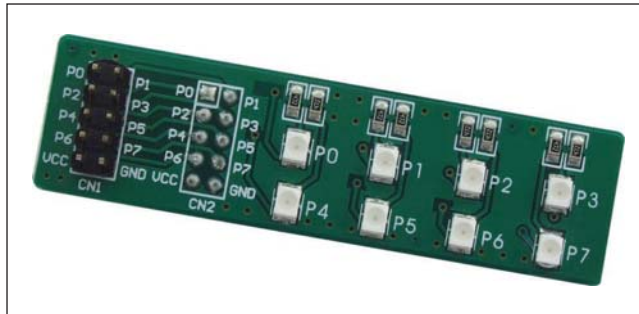

Figure 1: EasyLED additional board

How to connect the board?

The EasyLED additional board can be easily connected to a development system via an IDC10 connector CN2. The CN1 connector is used to access the port pins the additional board is connected to.

How to use the board?

The EasyLED board is used to show the logic level on the development system ports. When a pin is driven high (logic 1), the appropriate LED connected to that pin is turned on. Likewise, if a pin is driven low (logic 0), the appropriate LED will not illuminate.

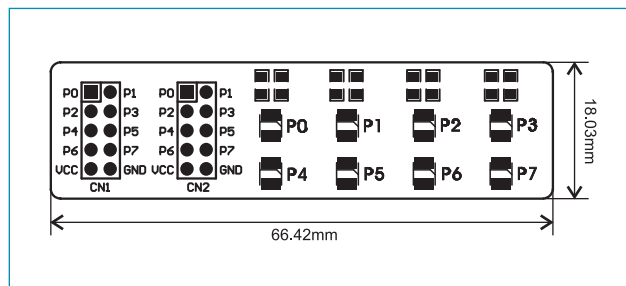

Figure 2: Dimensions of the EasyLED board

Note: When the EasyLED board features red LEDs, the value of the RN1 resistor is 4K7.

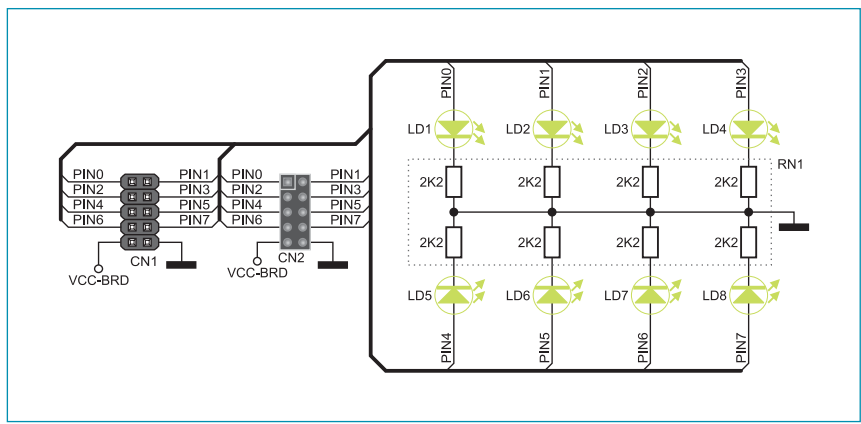

Figure 3: The EasyLED board connection schematic



SOFTWARE AND HARDWARE SOLUTIONS FOR EMBEDDED WORLD *...making it simple*

If you want to learn more about our products, please visit our website at www.mikroe.com

If you are experiencing some problems with any of our products or just need additional information, please place your ticket at www.mikroe.com/en/support

If you have any questions, comments or business proposals, do not hesitate to contact us at office@mikroe.com