



Chipsmall Limited consists of a professional team with an average of over 10 year of expertise in the distribution of electronic components. Based in Hongkong, we have already established firm and mutual-benefit business relationships with customers from,Europe,America and south Asia,supplying obsolete and hard-to-find components to meet their specific needs.

With the principle of “Quality Parts,Customers Priority,Honest Operation,and Considerate Service”,our business mainly focus on the distribution of electronic components. Line cards we deal with include Microchip,ALPS,ROHM,Xilinx,Pulse,ON,Everlight and Freescale. Main products comprise IC,Modules,Potentiometer,IC Socket,Relay,Connector.Our parts cover such applications as commercial,industrial, and automotives areas.

We are looking forward to setting up business relationship with you and hope to provide you with the best service and solution. Let us make a better world for our industry!



Contact us

Tel: +86-755-8981 8866 Fax: +86-755-8427 6832

Email & Skype: info@chipsmall.com Web: www.chipsmall.com

Address: A1208, Overseas Decoration Building, #122 Zhenhua RD., Futian, Shenzhen, China





mikromedia™

for PIC32®

Compact development system rich with on-board peripherals for all-round multimedia development on PIC32MX460F512L device.



TO OUR VALUED CUSTOMERS

I want to express my thanks to you for being interested in our products and for having confidence in MikroElektronika.

The primary aim of our company is to design and produce high quality electronic products and to constantly improve the performance thereof in order to better suit your needs.

A handwritten signature in white ink, appearing to read 'Nebojsa Matic', is positioned above the printed name and title.

Nebojsa Matic
General Manager

Table of contents

Introduction to mikromedia for PIC32®	4	Programming with mikroProg™ programmer	16
Package contains	5	mikroProg Suite™ for PIC® software	17
Key features	6	Programming with ICD2® or ICD3® programmer	18
System specification	7	4. Reset button	20
1. Power supply	8	5. Crystal oscillator	22
Battery power supply	8	6. microSD card slot	24
USB power supply	8	7. Touch screen	26
2. PIC32MX460F512L microcontroller	10	8. Audio module	28
Key microcontroller features	10	9. USB connection	30
3. Programming the microcontroller	11	10. Accelerometer	32
Programming with mikroBootloader	12	11. Flash memory	34
step 1 - Connecting mikromedia	12	12. Pads	36
step 2 - Browsing for .HEX file	13	13. Pinout	37
step 3 - Selecting .HEX file	13	14. Dimensions	38
step 4 - Uploading .HEX file	14	15. mikromedia accessories	39
step 5 - Finish upload	15	What's next?	40

Introduction to mikromedia for PIC32®

The **mikromedia for PIC32®** is a compact development system with lots of on-board peripherals which allow development of devices with multimedia contents. The central part of the system is a 32-bit **PIC32MX460F512L** microcontroller. The mikromedia for PIC32® features integrated modules such as stereo MP3 codec, **TFT 320x240 touch screen** display, accelerometer, USB connector, audio connector, MMC/SD card slot, 8 Mbit flash memory, 2x26 connection pads and other. It comes pre-programmed with USB HID bootloader, but can also be programmed with external programmers, such as mikroProg™ or ICD2/3. Mikromedia is compact and slim, and perfectly fits in the palm of the hand, which makes it convenient platform for mobile devices.

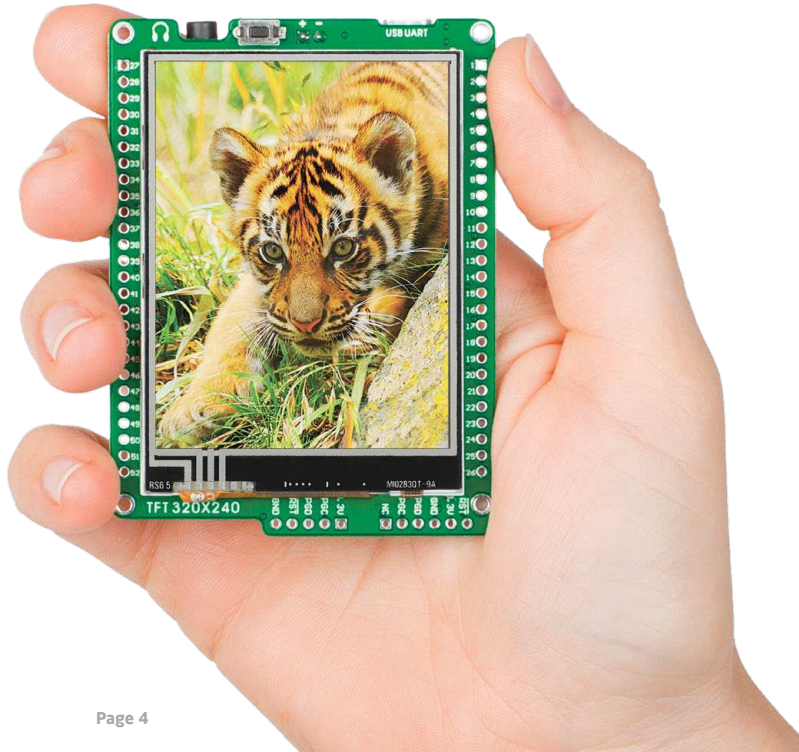

Package contains



01 Damage resistant protective box

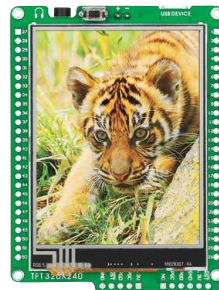

02 mikromedia for dsPIC33® development system



03 User's guide, schematic and pinout



04 USB cable, two 1x26, one 1x6 and one 1x5 male headers

Key features

- 01 Connection Pads
- 02 TFT 320x240 display
- 03 USB MINI-B connector
- 04 CHARGE indication LED
- 05 LI-Polymer battery connector
- 06 3.5mm headphone connector
- 07 Power supply regulator
- 08 Serial Flash memory
- 09 RESET button
- 10 VS1053 Stereo mp3 coder/decoder
- 11 PIC32MX460F512L microcontroller
- 12 Accelerometer
- 13 Crystal oscillator
- 14 Power indication LED
- 15 microSD Card Slot
- 16 ICD2/3 connector
- 17 mikroProg connector



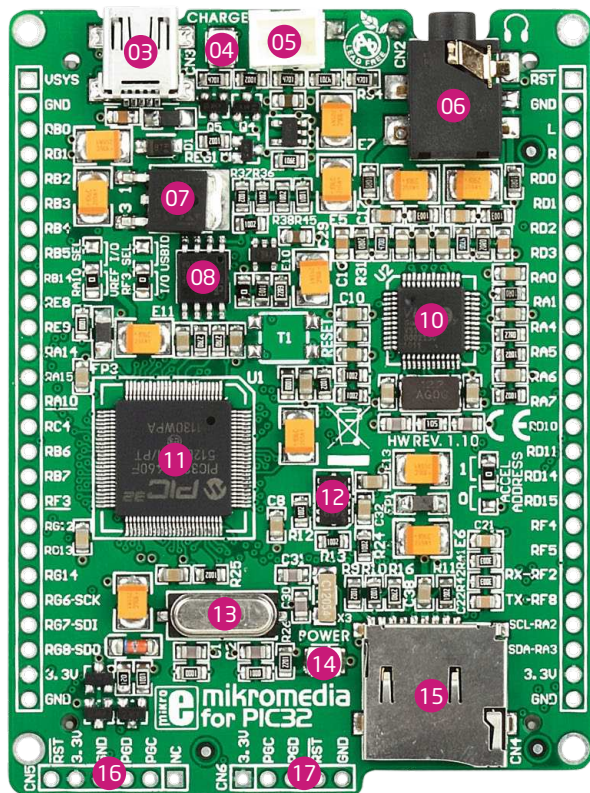

System specification



power supply
Via USB cable (5V DC)



power consumption
58 mA with erased MCU (when on-board modules are inactive)



board dimensions
81.2 x 60.5 mm (3.19 x 2.38 inch)



weight
~50g (0.11lbs)



class B product
Product complies with the Class B limit of EN 55022 and can be used in the domestic, residential, commercial and industrial environments.



CAUTION: Electrostatic Sensitive Device
Permanent damage may occur on devices subjected to high energy electrostatic discharges which readily accumulate on the human body or test equipment and can discharge without detection.

1. Power supply

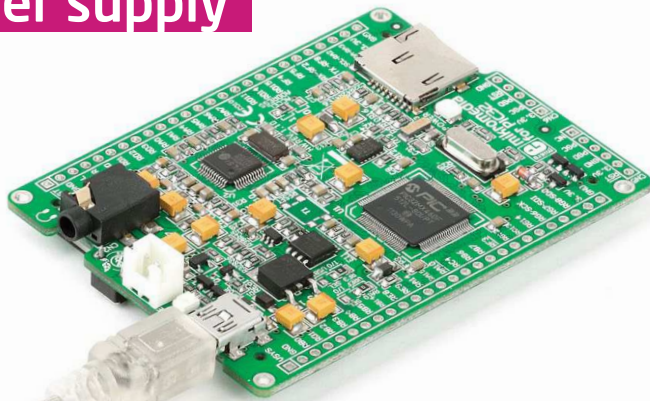

Figure 1-1:
Connecting USB
power supply

USB power supply

You can apply power supply to the board using **MINI-B USB** cable provided with the board. On-board voltage regulators provide the appropriate voltage levels to each component on the board. **Power LED (GREEN)** will indicate the presence of power supply.

Battery power supply

You can also power the board using **Li-Polymer** battery, via on-board battery connector. On-board battery charger circuit **MCP73832** enables you to charge the battery over USB connection. **LED diode (RED)** will indicate when battery is charging. Charging current is ~250mA and charging voltage is 4.2V DC.

Figure 1-2: Connecting
Li-Polymer battery

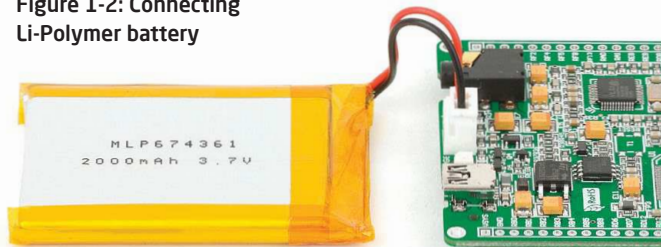

DATA BUS

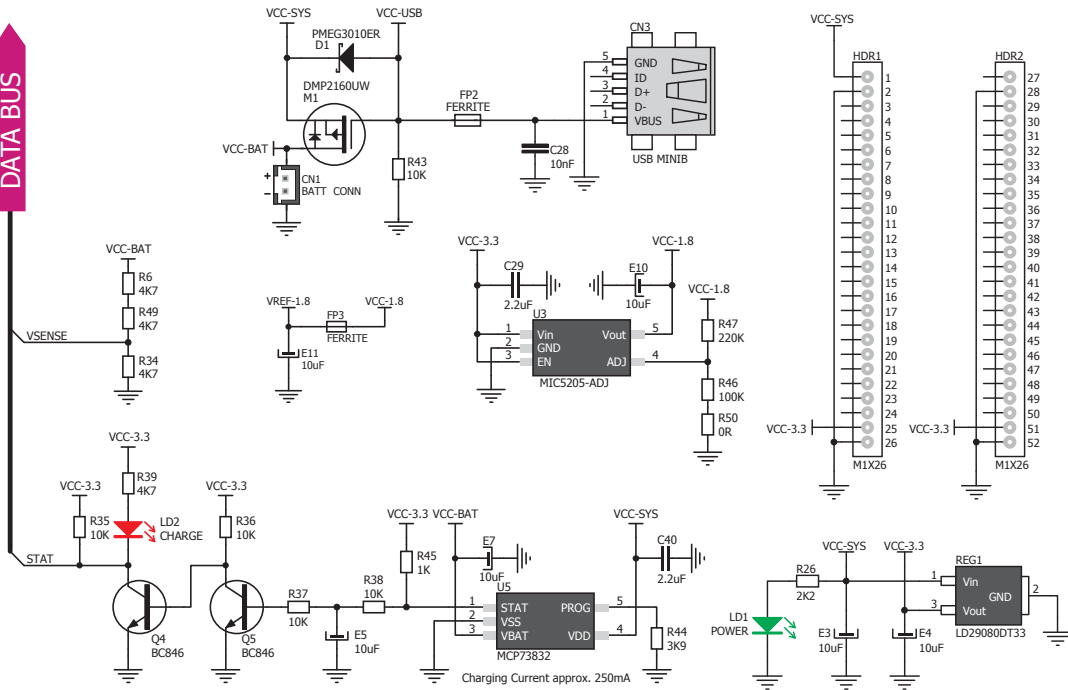

Figure 1-3: Power supply schematics

2. PIC32MX460F512L microcontroller

The **mikromedia for PIC32®** development system comes with the **PIC32MX460F512L** microcontroller. This high-performance 32-bit microcontroller with its integrated modules and in combination with other on-board modules is ideal for multimedia applications.

Key microcontroller features

- 1.56 DMIPS/MHz, 32-bit MIPS M4K Core;
- 512K Flash (plus 12K boot Flash);
- 32K RAM (can execute from RAM);
- 85 I/O pins;
- SPI, I²C, A/D;
- 16-bit, 32-bit Digital Timers;
- Internal Oscillator 8MHz, 32kHz;
- RTCC; etc.

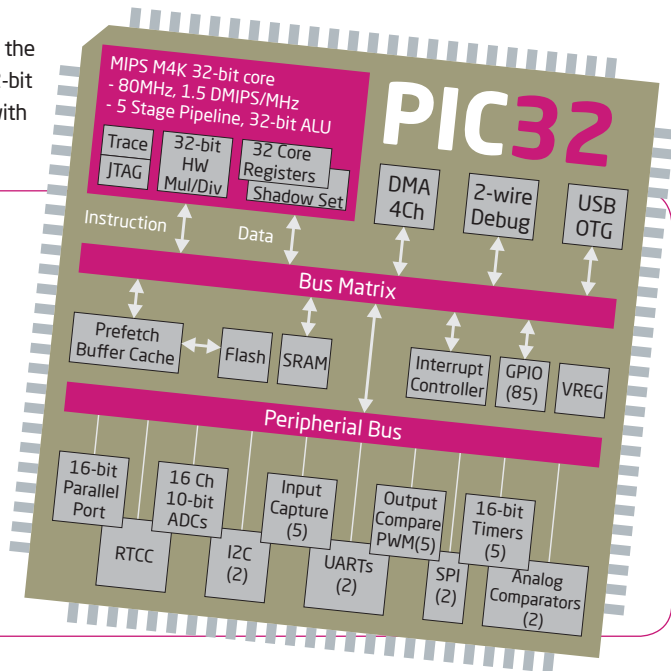

3. Programming the microcontroller

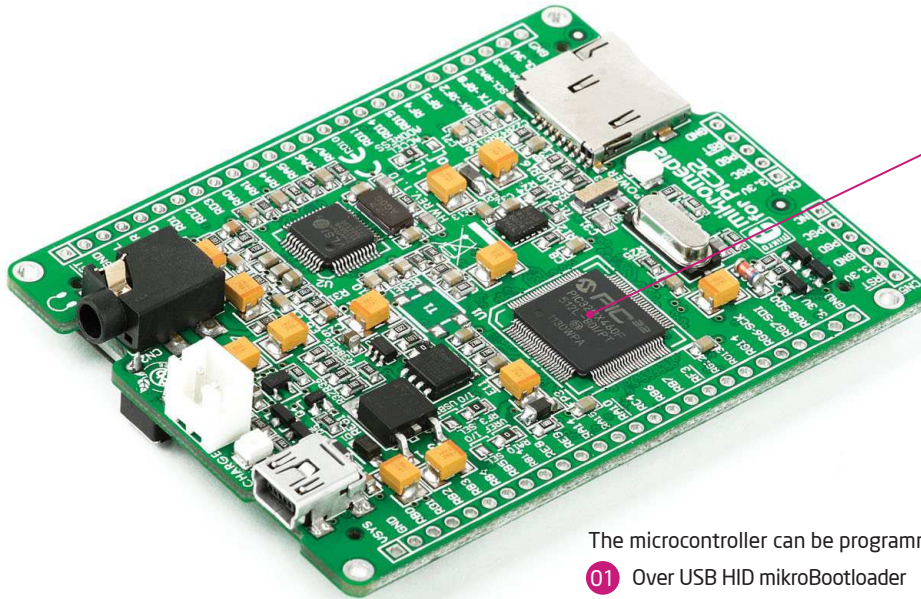

Figure 3-1:
PIC32MX460F512L
microcontroller

The microcontroller can be programmed in three ways:

- 01 Over USB HID mikroBootloader
- 02 Using mikroProg™ external programmer
- 03 Using ICD2/3 external programmer

Programming with mikroBootloader

You can program the microcontroller with bootloader which is preprogrammed into the device by default. To transfer .hex file from a PC to MCU you need bootloader software (**mikroBootloader USB HID**) which can be downloaded from:

 www.mikroe.com/downloads/get/2153/mikrobootloader_usb_hid_STM32F407VGT6.zip

Upon download, unzip it to desired location and start the mikroBootloader application:

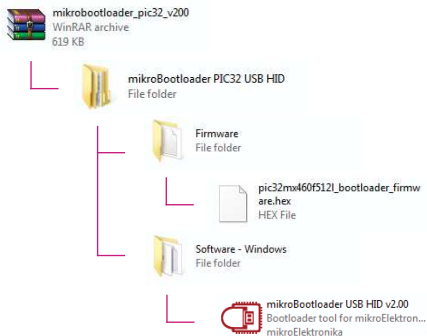

step 1 - Connecting mikromedia



Figure 3-2: USB HID mikroBootloader window

- 01** To start, connect the USB cable, or if already connected press the **Reset** button on your mikromedia board. Click the **Connect** button within 5s to enter the bootloader mode, otherwise existing microcontroller program will execute.

step 2 - Browsing for .HEX file



Figure 3-3: Browse for HEX

- 01 Click the **Browse for HEX** button and from a pop-up window (**Figure 3.4**) choose the .HEX file which will be uploaded to MCU memory.

step 3 - Selecting .HEX file

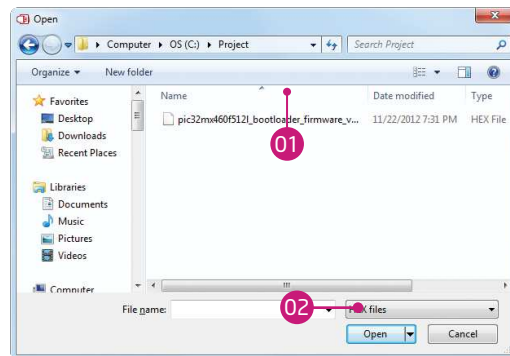

Figure 3-4: Selecting HEX

- 01 Select .HEX file using open dialog window.
02 Click the **Open** button.

step 4 - Uploading .HEX file



Figure 3-5: Begin uploading

01 To start .HEX file bootloading click the **Begin uploading** button.



Figure 3-6: Progress bar

01 Progress bar enables you to monitor .HEX file uploading.

step 5 - Finish upload

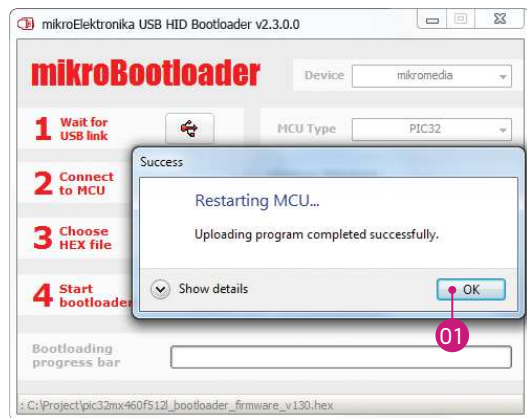

Figure 3-7: Restarting MCU

- 01 Click **OK** button after the uploading process is finished
- 02 Press **Reset** button on mikromedia board and wait for 5 seconds. Your program will run automatically



Figure 3-8: mikroBootloader ready for next job

Programming with mikroProg™ programmer

The microcontroller can be programmed with **mikroProg™ programmer** and **mikroProg Suite™ for PIC®** software. The mikroProg™ programmer is connected to the development system via the CN6 connector, **Figure 3-9**.



Figure 3-9:
Connecting mikroProg™ to mikromedia™

mikroProg™ is a fast USB 2.0 programmer with mikroCD™ hardware In-Circuit Debugger. Smart engineering allows mikroProg™ to support PIC10®, PIC12®, PIC16®, PIC18®, dsPIC30/33®, PIC24® and PIC32® devices in a single programmer. It supports over 570 microcontrollers from Microchip®. Outstanding performance, easy operation and elegant design are it's key features.

mikroProg Suite™ for PIC® software



mikroProg™ programmer requires special programming software called **mikroProg Suite™ for PIC®**. This software is used for programming of ALL Microchip® microcontroller families, including PIC10®, PIC12®, PIC16®, PIC18®, dsPIC30/33®, PIC24® and PIC32®. Software has intuitive interface and SingleClick™ programming technology. Just by downloading the latest version of **mikroProg Suite™** your programmer is ready to program new devices. **mikroProg Suite™** is updated regularly, at least four times a year, so your programmer will be more and more powerful with each new release.

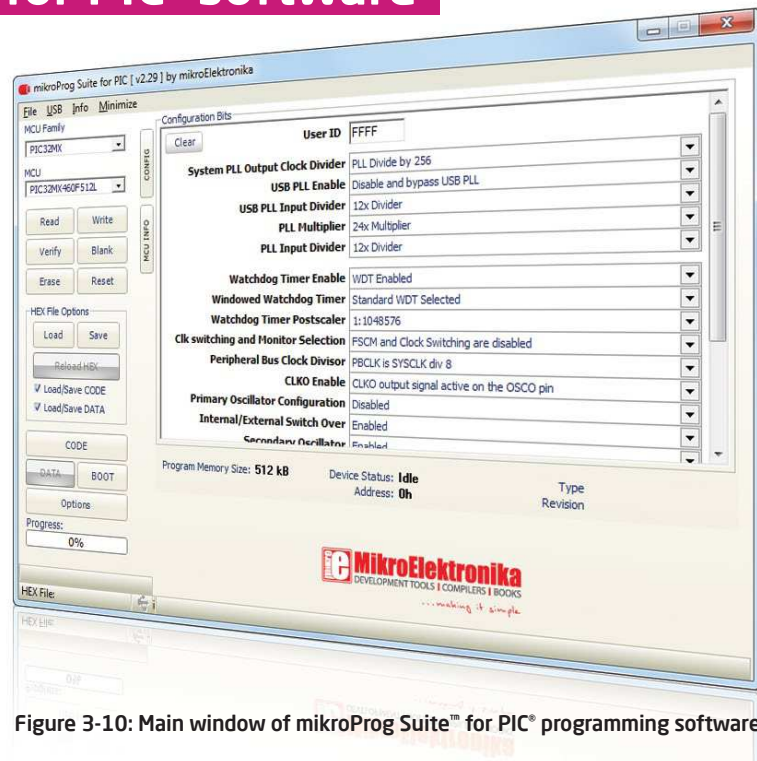

Figure 3-10: Main window of mikroProg Suite™ for PIC® programming software

Programming with ICD2[®] or ICD3[®] programmer

The microcontroller can be also programmed with **ICD2[®] or ICD3[®] programmer**. These programmers connects with mikromedia board via **ICD2 CONNECTOR BOARD**.

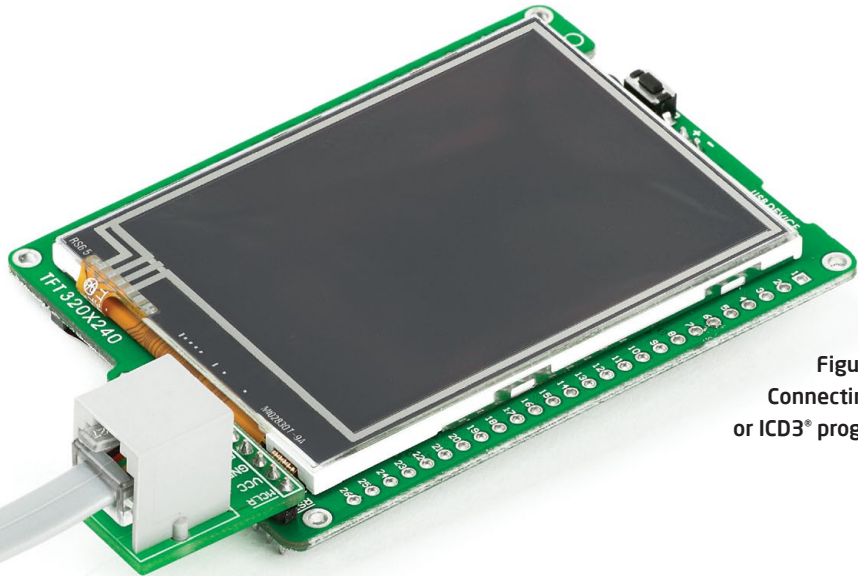

Figure 3-12:
Connecting ICD2[®]
or ICD3[®] programmer

In order to enable the ICD2[®] and ICD3[®] programmers to be connected to the mikromedia board, it is necessary to provide the appropriate connector such as the **ICD2 CONNECTOR BOARD**. This connector should be first soldered on the CN5 connector. Then you should plug the ICD2[®] or ICD3[®] programmer into it, **Figure 3-11**.

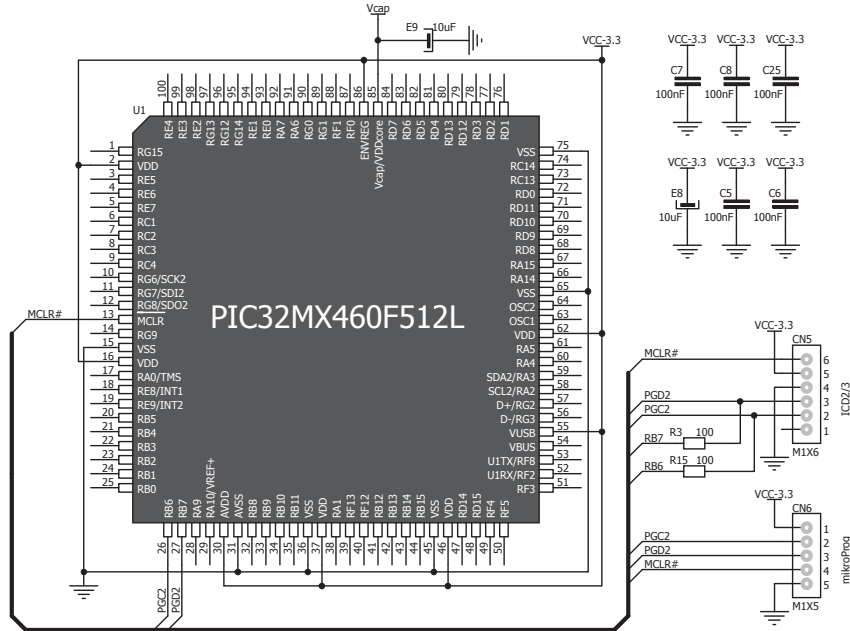
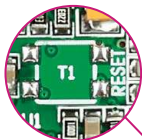
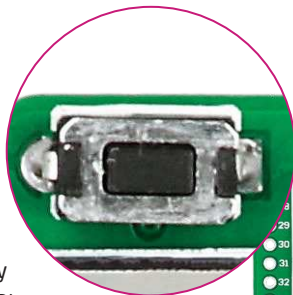

Figure 3-13: mikroProg™ & ICD2 / ICD3 programmer connection schematic

4. Reset button

Board is equipped with reset button, which is located at the top of the front side (**Figure 4-2**). If you want to reset the circuit, press the reset button. It will generate low voltage level on microcontroller reset pin (input). In addition, a reset can be externally provided through **pin 27** on side headers (**Figure 4-3**).



NOTE | You can also solder additional reset button on the appropriate place at the back side of the board, **Figure 4-1**.

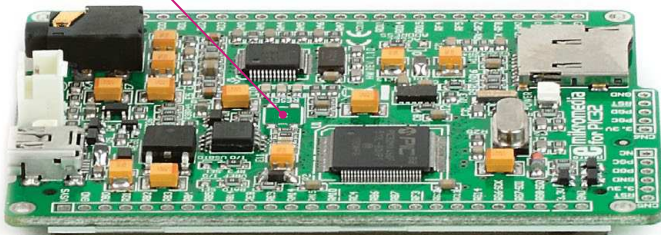

Figure 4-1: Location of additional reset button

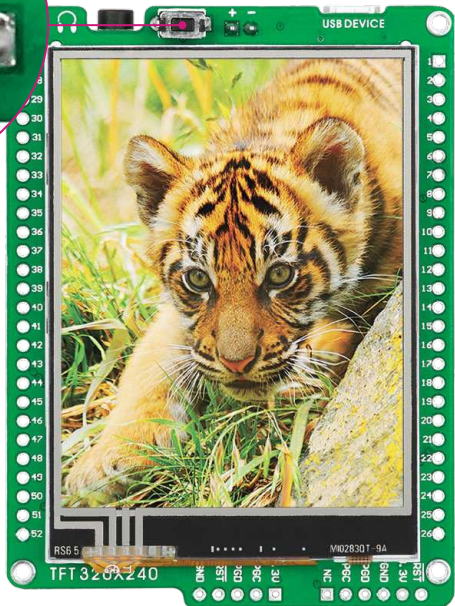

Figure 4-2: Frontal reset button

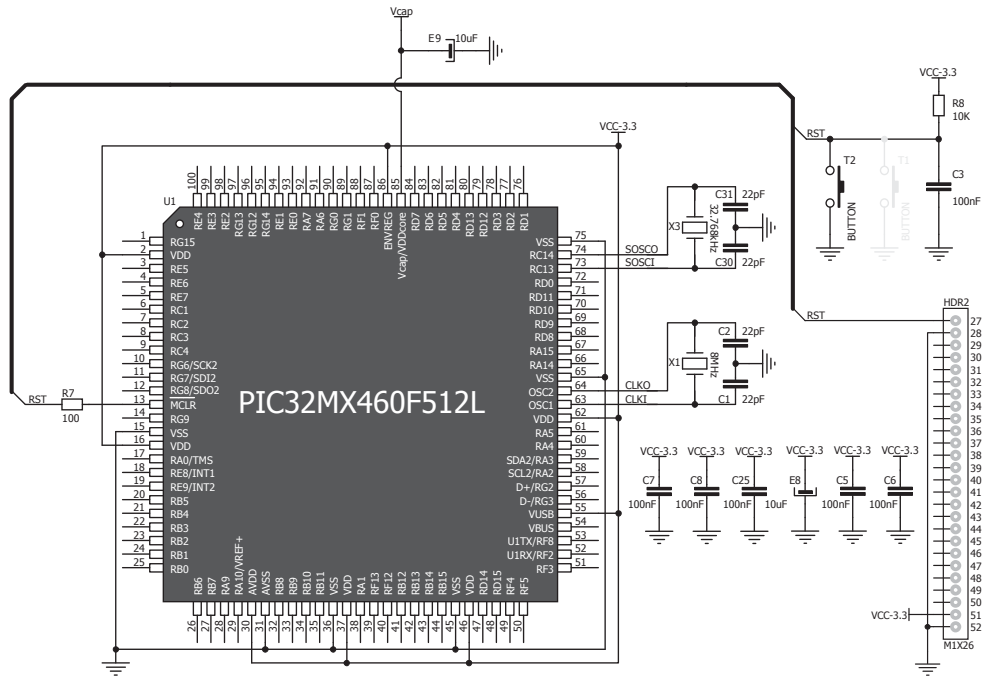
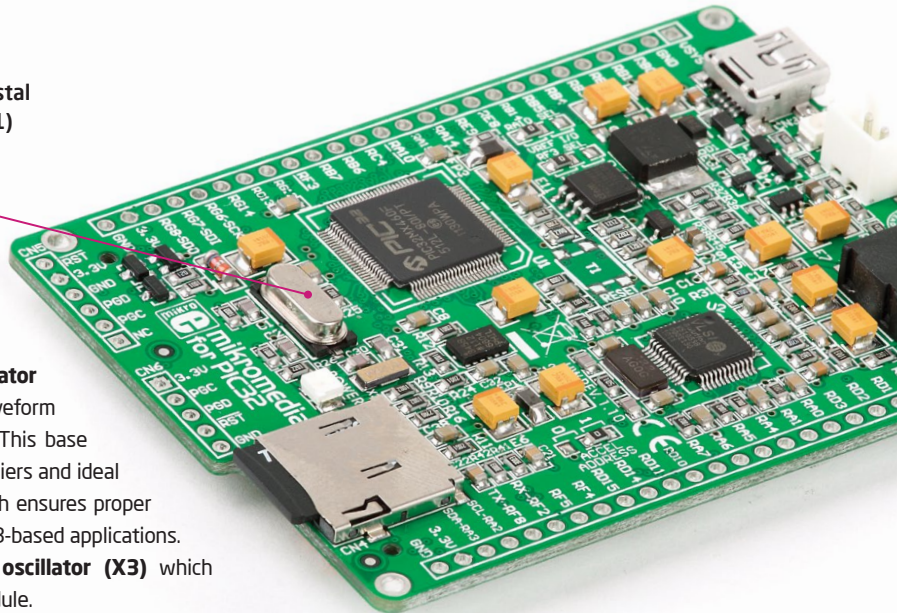

Figure 4-3: Reset circuit schematic

5. Crystal oscillator



Figure 5-1:
External crystal oscillator (X1)



Board is equipped with **8MHz crystal oscillator (X1)** circuit that provides external clock waveform to the microcontroller CLK0 and CLK1 pins. This base frequency is suitable for further clock multipliers and ideal for generation of necessary USB clock, which ensures proper operation of bootloader and your custom USB-based applications. Board also contains **32.768kHz Crystal oscillator (X3)** which provides external clock for internal **RTCC** module.

NOTE | *The use of crystal in all other schematics is implied even if it is purposely left out because of the schematics clarity.*

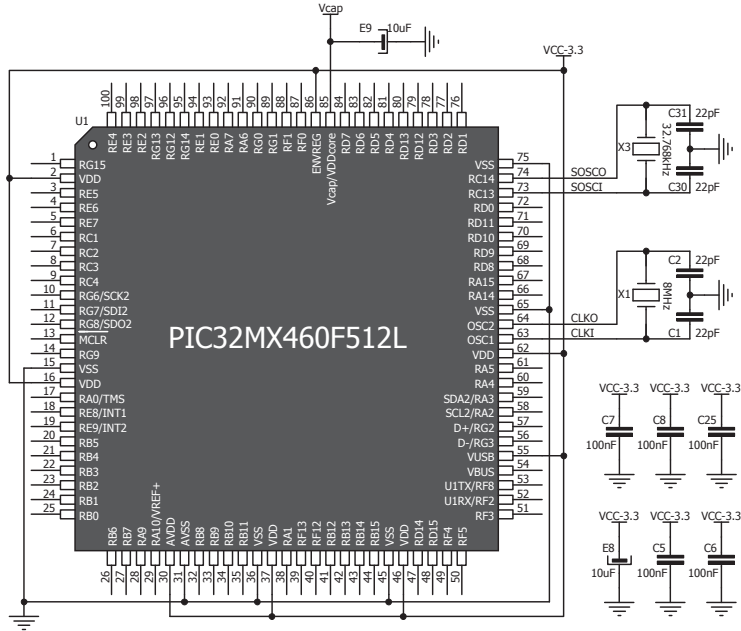

Figure 5-2: Crystal oscillator schematic

6. microSD card slot

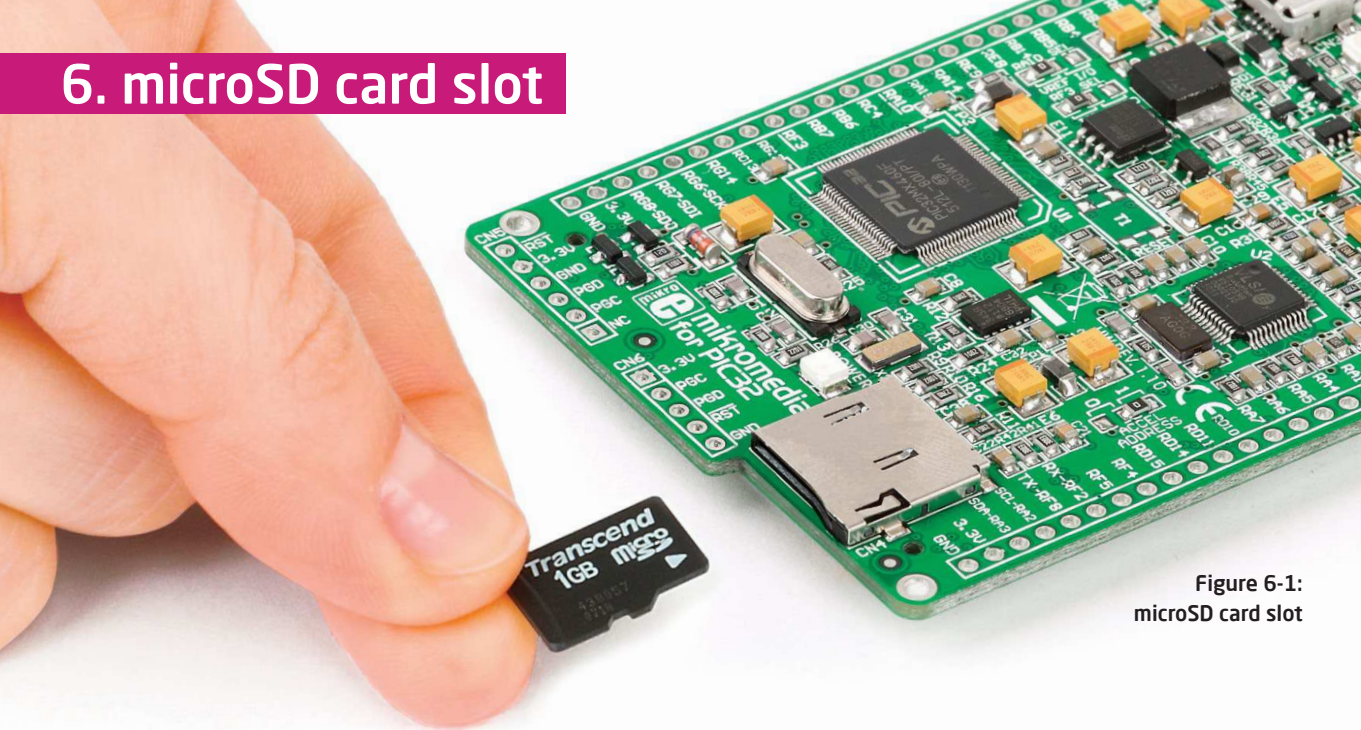

Figure 6-1:
microSD card slot

Board contains **microSD card slot** for using microSD cards in your projects. It enables you to store large amounts of data externally, thus saving microcontroller memory. microSD cards use Serial Peripheral Interface (**SPI**) for communication with the microcontroller.

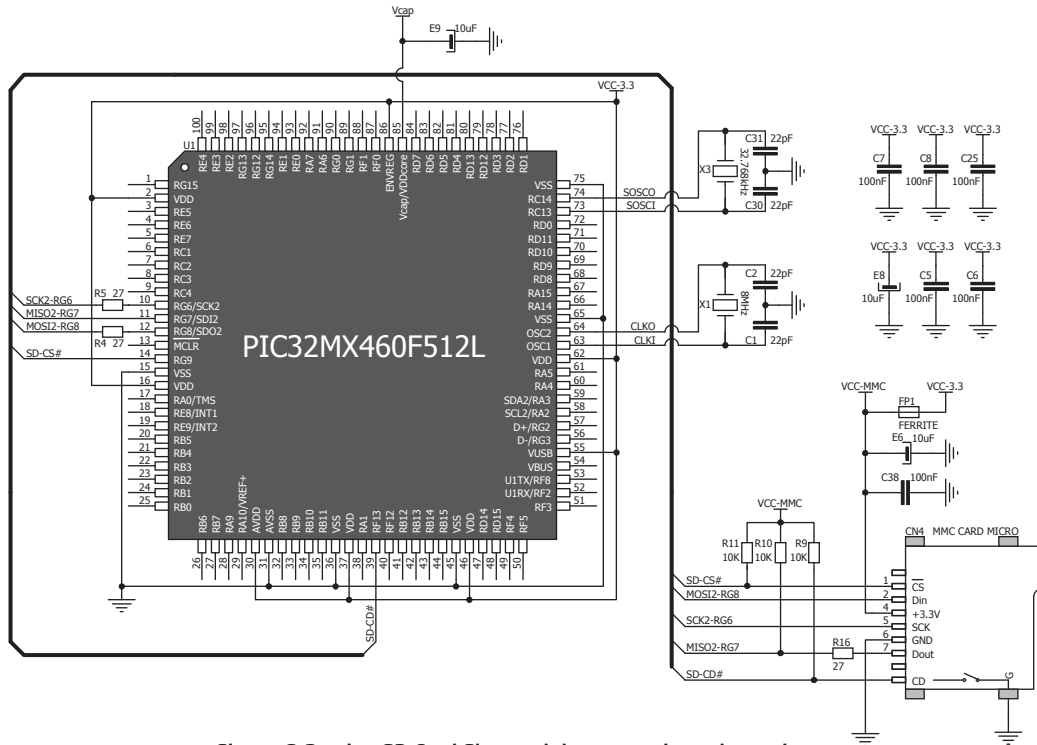

Figure 6-2: microSD Card Slot module connection schematic