



Chipsmall Limited consists of a professional team with an average of over 10 year of expertise in the distribution of electronic components. Based in Hongkong, we have already established firm and mutual-benefit business relationships with customers from,Europe,America and south Asia,supplying obsolete and hard-to-find components to meet their specific needs.

With the principle of "Quality Parts,Customers Priority,Honest Operation,and Considerate Service",our business mainly focus on the distribution of electronic components. Line cards we deal with include Microchip,ALPS,ROHM,Xilinx,Pulse,ON,Everlight and Freescale. Main products comprise IC,Modules,Potentiometer,IC Socket,Relay,Connector.Our parts cover such applications as commercial,industrial, and automotives areas.

We are looking forward to setting up business relationship with you and hope to provide you with the best service and solution. Let us make a better world for our industry!



Contact us

Tel: +86-755-8981 8866 Fax: +86-755-8427 6832

Email & Skype: info@chipsmall.com Web: www.chipsmall.com

Address: A1208, Overseas Decoration Building, #122 Zhenhua RD., Futian, Shenzhen, China



user's guide to

Expand development system capabilities by adding RS485 communication accessory board

RS485

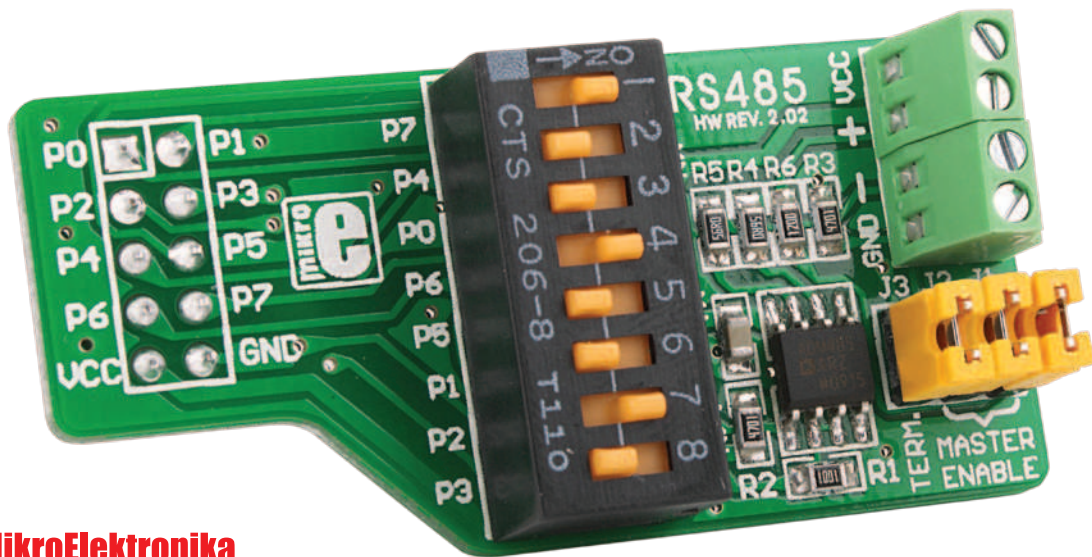

TO OUR VALUED CUSTOMERS

I want to express my thanks to you for being interested in our products and for having confidence in Mikroelektronika.

The primary aim of our company is to design and produce high quality electronic products and to constantly improve the performance thereof in order to better suit your needs.

A handwritten signature in white ink, appearing to read 'N. Matic', is positioned above the name and title of the General Manager.

Nebojsa Matic
General Manager

Table of Contents

Introduction to RS485	4
Key features	4
System Specification	5
1. Connecting with development system	6
2. DIP switch settings	7
3. Connecting RS485 with other RS485 devices	8
4. Jumper settings	9
5. Schematic	10
6. Dimensions	11

Introduction to RS485

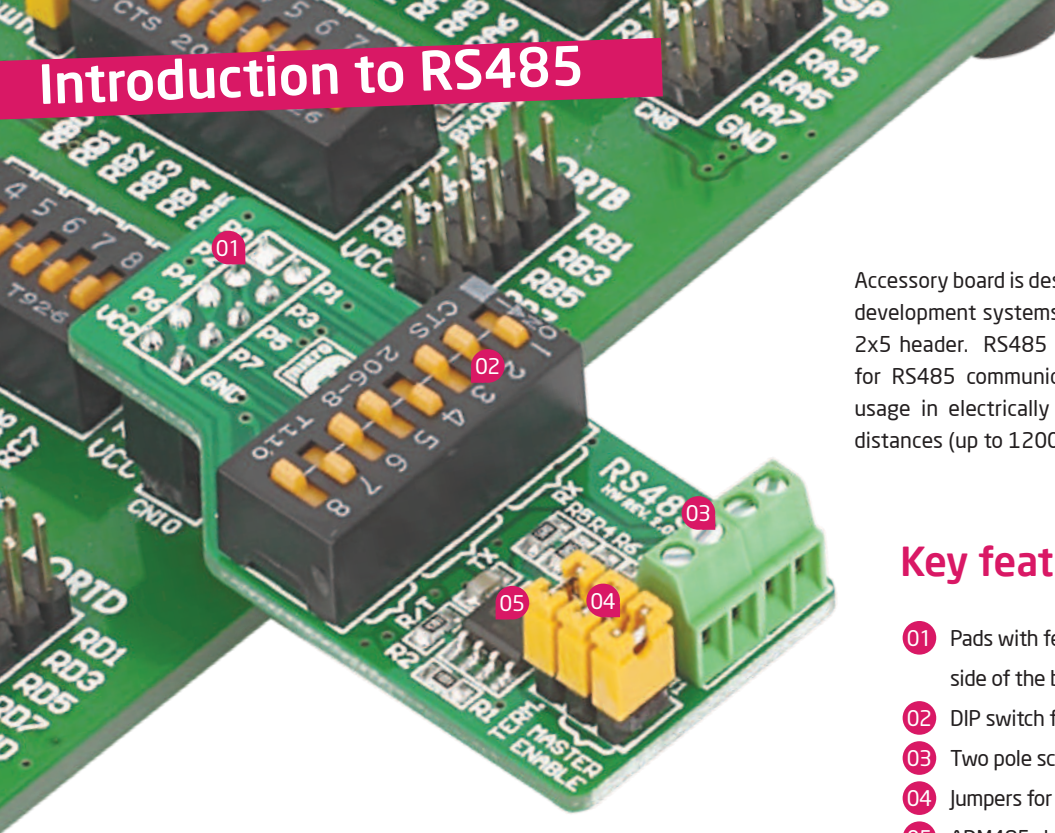

Accessory board is designed for usage with various development systems and other MCU device with 2x5 header. RS485 additional board is designed for RS485 communication which is suitable for usage in electrically noisy environment on long distances (up to 1200m (4000ft)).

Key features

- 01 Pads with female 2x5 header on back side of the board.
- 02 DIP switch for pin selection.
- 03 Two pole screw terminals CN2 and CN3.
- 04 Jumpers for selecting slave/master mode.
- 05 ADM485 chip

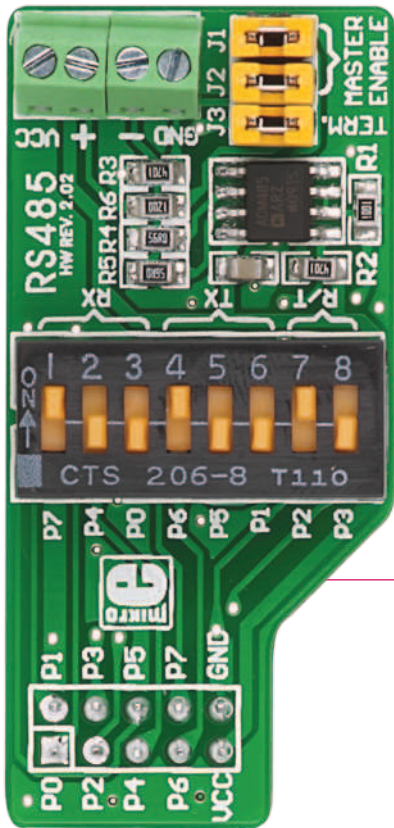

System Specification



power supply

5V DC



power consumption

~2mA outputs enabled



board dimensions

50.42 x 23.88mm (1.99 x 0.94")



weight

~9g (0.02 lbs)

2. DIP switch settings

In order to connect RS485 to different development system it is necessary to make settings on DIP switch SW1. Every pin on DIP switch SW1 is connected to different pin of 2x5 female header. In table 1 is given list which switch on DIP switch SW1 should be turned ON for different development system.

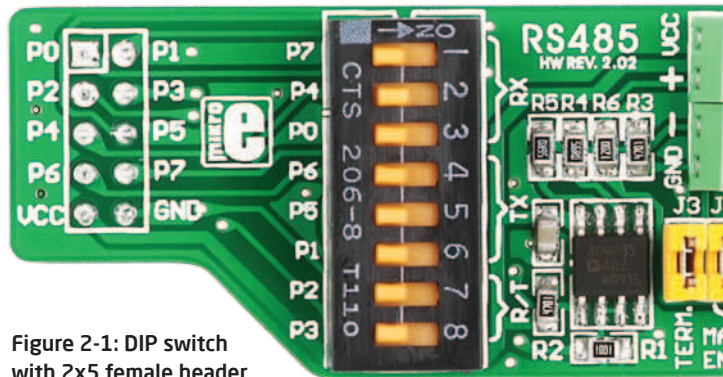

Figure 2-1: DIP switch with 2x5 female header

Table 1

Development system:	Turn ON switch number:	Pin on female 2x5 header:	Pin function:
EasyAVR, BIGAVR, Easy8051, BIG 8051	3	P0	RX
EasyAVR, BIGAVR, Easy8051, BIG 8051	6	P1	TX
BIGdsPIC, dsPIC PRO, EasydsPIC	2	P4	RX
BIGdsPIC, dsPIC PRO, EasydsPIC	5	P5	TX
EasyPIC, BIGPIC	4	P6	TX
EasyPIC, BIGPIC	1	P7	RX
R/T lines are defined in user program.	7	P2	R/T
	8	P3	R/T

3. Connecting RS485 with other RS485 devices

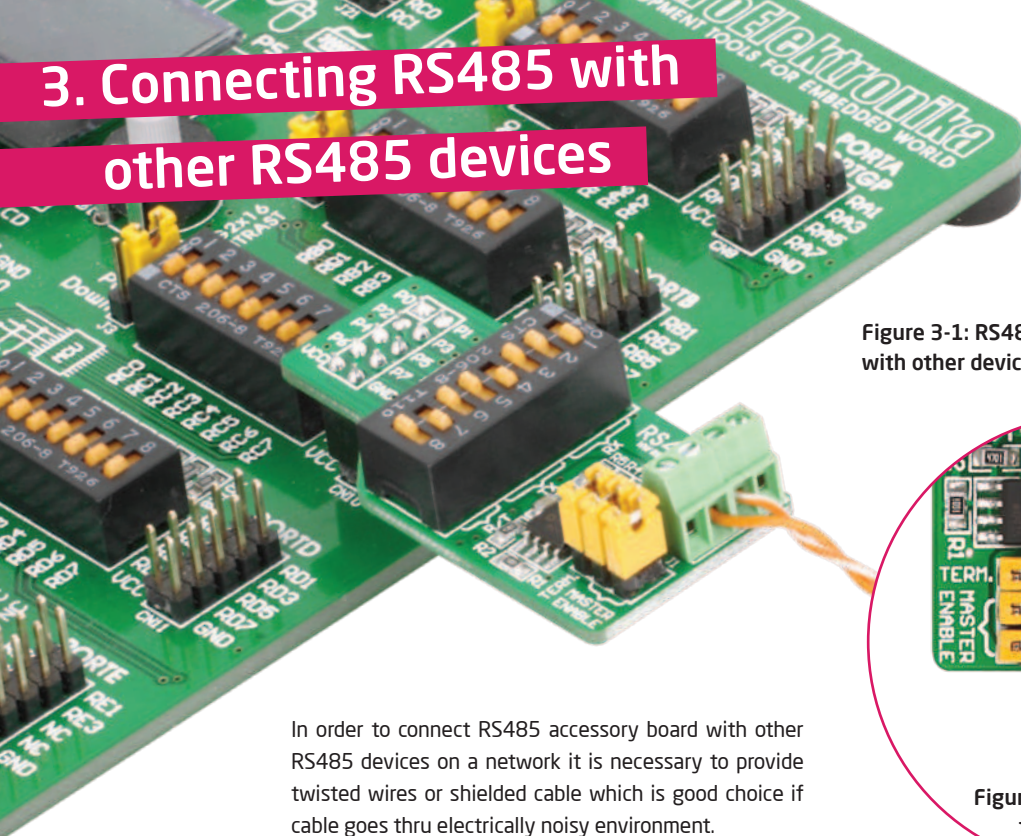

Figure 3-1: RS485 connected with other device via wire

In order to connect RS485 accessory board with other RS485 devices on a network it is necessary to provide twisted wires or shielded cable which is good choice if cable goes thru electrically noisy environment.

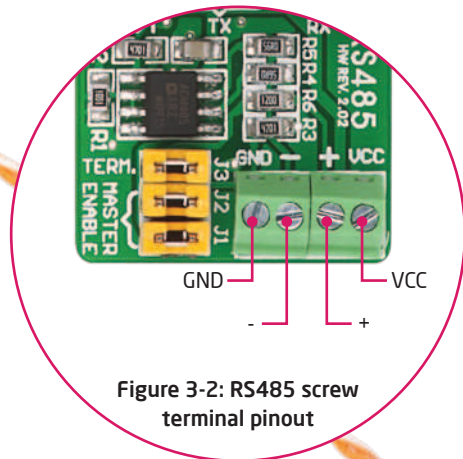
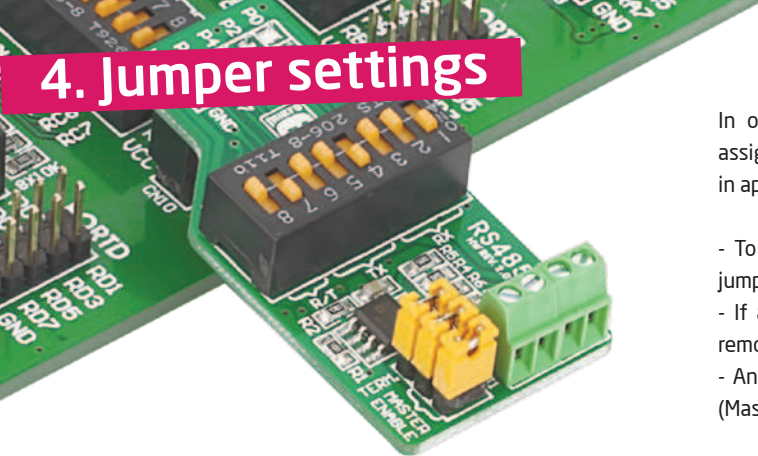

Figure 3-2: RS485 screw terminal pinout

4. Jumper settings



In order to determine which node in RS485 network will be assigned to RS485 accessory board it is necessary to set jumpers in appropriate position.

- To set accessory board to first node in RS485 network place jumpers J1, J2 and J3 (Master and Term. jumpers are placed);
- If accessory board is somewhere between first and last node remove all jumpers (Master and Term. are off); and
- And to place accessory board to last node just place jumper J1 (Master off and Term. is placed).

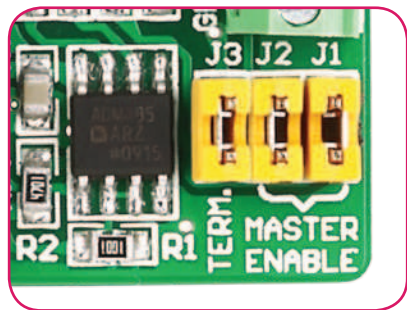

Figure 4-1: First node

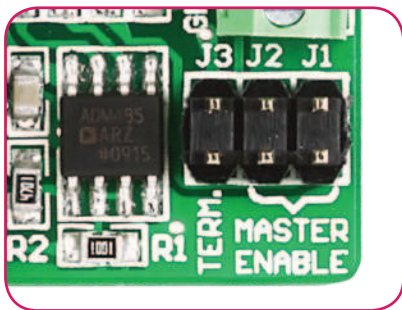

Figure 4-2: Node between first and last

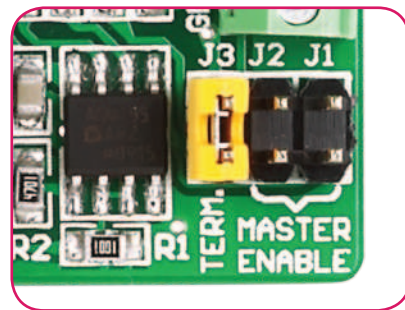

Figure 4-3: Last node

6. Dimensions

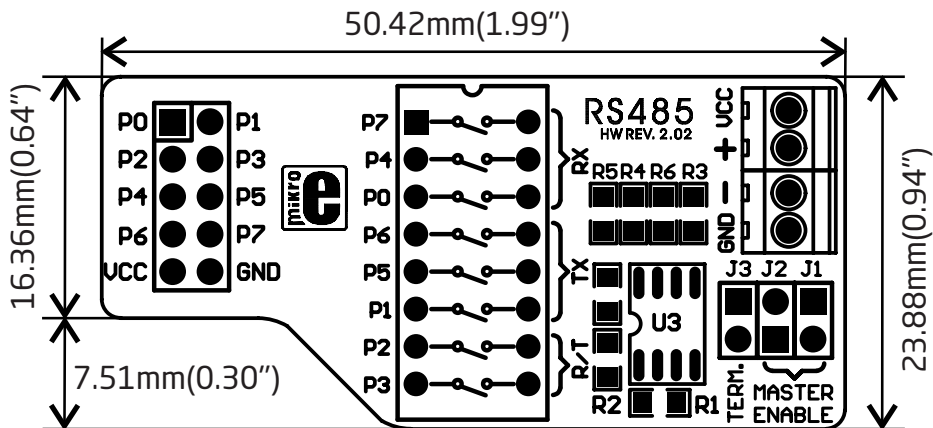

Figure 6-1: Dimensions

Notes:

Notes:

Notes:

DISCLAIMER

All the products owned by MikroElektronika are protected by copyright law and international copyright treaty. Therefore, this manual is to be treated as any other copyright material. No part of this manual, including product and software described herein, may be reproduced, stored in a retrieval system, translated or transmitted in any form or by any means, without the prior written permission of MikroElektronika. The manual PDF edition can be printed for private or local use, but not for distribution. Any modification of this manual is prohibited.

MikroElektronika provides this manual 'as is' without warranty of any kind, either expressed or implied, including, but not limited to, the implied warranties or conditions of merchantability or fitness for a particular purpose.

MikroElektronika shall assume no responsibility or liability for any errors, omissions and inaccuracies that may appear in this manual. In no event shall MikroElektronika, its directors, officers, employees or distributors be liable for any indirect, specific, incidental or consequential damages (including damages for loss of business profits and business information, business interruption or any other pecuniary loss) arising out of the use of this manual or product, even if MikroElektronika has been advised of the possibility of such damages. MikroElektronika reserves the right to change information contained in this manual at any time without prior notice, if necessary.

HIGH RISK ACTIVITIES

The products of MikroElektronika are not fault - tolerant nor designed, manufactured or intended for use or resale as on - line control equipment in hazardous environments requiring fail - safe performance, such as in the operation of nuclear facilities, aircraft navigation or communication systems, air traffic control, direct life support machines or weapons systems in which the failure of Software could lead directly to death, personal injury or severe physical or environmental damage ('High Risk Activities'). MikroElektronika and its suppliers specifically disclaim any expressed or implied warranty of fitness for High Risk Activities.

TRADEMARKS

The Mikroelektronika name and logo, the Mikroelektronika logo, mikroC, mikroC PRO, mikroBasic, mikroBasic PRO, mikroPascal, mikroPascal PRO, AVRflash, PICflash, dsPICprog, 18FJprog, PSOCprog, AVRprog, 8051prog, ARMflash, EasyPIC5, EasyPIC6, BigPIC5, BigPIC6, dsPIC PRO4, Easy8051B, EasyARM, EasyAVR5, EasyAVR6, BigAVR2, EasydsPIC4A, EasyPSoC4, EasyAVR Stamp LV18FJ, LV24-33A, LV32MX, PIC32MX4 MultiMedia Board, PICPLC16, PICPLC8 PICPLC4, SmartGSM/GPRS, UNI-DS are trademarks of Mikroelektronika. All other trademarks mentioned herein are property of their respective companies.

All other product and corporate names appearing in this manual may or may not be registered trademarks or copyrights of their respective companies, and are only used for identification or explanation and to the owners' benefit, with no intent to infringe.

RS485

v2.02

If you want to learn more about our products, please visit our website at www.mikroe.com

If you are experiencing some problems with any of our products or just need additional information, please place your ticket at www.mikroe.com/en/support

If you have any questions, comments or business proposals,
do not hesitate to contact us at office@mikroe.com