



Chipsmall Limited consists of a professional team with an average of over 10 year of expertise in the distribution of electronic components. Based in Hongkong, we have already established firm and mutual-benefit business relationships with customers from,Europe,America and south Asia,supplying obsolete and hard-to-find components to meet their specific needs.

With the principle of "Quality Parts,Customers Priority,Honest Operation,and Considerate Service",our business mainly focus on the distribution of electronic components. Line cards we deal with include Microchip,ALPS,ROHM,Xilinx,Pulse,ON,Everlight and Freescale. Main products comprise IC,Modules,Potentiometer,IC Socket,Relay,Connector.Our parts cover such applications as commercial,industrial, and automotives areas.

We are looking forward to setting up business relationship with you and hope to provide you with the best service and solution. Let us make a better world for our industry!



Contact us

Tel: +86-755-8981 8866 Fax: +86-755-8427 6832

Email & Skype: info@chipsmall.com Web: www.chipsmall.com

Address: A1208, Overseas Decoration Building, #122 Zhenhua RD., Futian, Shenzhen, China



BlueTooth Stick™

Manual

All Mikroelektronika's development systems feature a large number of peripheral modules expanding microcontroller's range of application and making the process of program testing easier. In addition to these modules, it is also possible to use numerous additional modules linked to the development system through the I/O port connectors. Some of these additional modules can operate as stand-alone devices without being connected to the microcontroller.

Additional Board

 **MikroElektronika**

SOFTWARE AND HARDWARE SOLUTIONS FOR EMBEDDED WORLD ...making it simple

BlueTooth Stick

The BlueTooth Stick is an additional board which enables the microcontroller to communicate with wireless devices.

Key features:

- Serial UART communication;
- Frequency of 2402 ~ 2480MHz;
- Range up to 100m;
- 3.3V DC power supply.

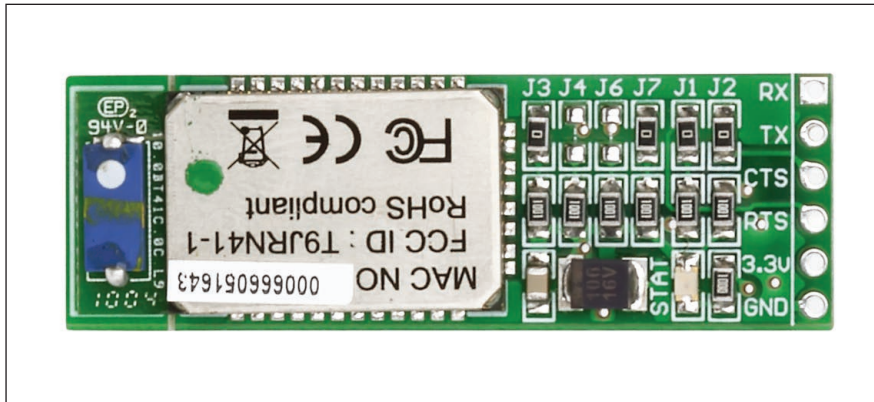

Figure 1: BlueTooth Stick

Appliance:

The BlueTooth Stick additional board is used as a wireless interface between devices which use bluetooth communication. For communication with a microcontroller, the additional board uses serial UART communication. To connect this additional board to a microcontroller you can use six marked pads (CN1). It is also possible to solder a 1x6 male header to pads.

Jumper settings:

The additional board comes with soldered smd jumpers which can be removed by desoldering. Jumpers J1, J2, J3 and J7 are soldered while jumpers J4 and J6 can be additionally soldered by the user.

Jumpers description:

- J1: Enables connection between RTS pad and bluetooth module RN41;
- J2: Enables connection between CTS pad and bluetooth module RN41;
- J3: Connects VCC-3.3V (Pull-up) to PIO3 pin on bluetooth module, Auto discovery = HIGH;
- J4: Connects VCC-3.3V (Pull-up) to PIO4 pin on bluetooth module, Set factory defaults;
- J6: Connects VCC-3.3V (Pull-up) to PIO6 pin on bluetooth module, Set BT master (HIGH=auto-master mode); and
- J7: Connects VCC-3.3V (Pull-up) to PIO7 pin on bluetooth module, Set Baud rate (HIGH = force 9600, LOW = 115K or firmware setting).

Pinout:

Pads pinout:

- RX: MCU UART receive Input;
- TX: MCU UART transmit output;
- CTS: MCU Clear To Send;
- RTS: MCU Request To Send;
- VCC-3.3V: 3.3V DC power supply; and
- GND: Ground.

Bluetooth module RN41 pinout:

- PIO3: Auto discovery = HIGH. Input to RN41 with weak pulldown;
- PIO4: Set factory defaults. Input to RN41 with weak pulldown;
- PIO5: Status, toggles based on state, LOW on connect. Output from RN41;
- PIO6: Set BT master (HIGH=auto-master mode). Input to RN41 with weak pulldown;
- PIO7: Set Baud rate (HIGH = force 9600, LOW = 115K or firmware setting). Input to RN41 with weak pulldown;
- UART-RX: UART receive. Input to RN41;
- UART-TX: UART transmit output. High level output from RN41;
- UART-CTS: UART CTS, if set HIGH, disables transmitter. Low level input to RN41;
- UART-RTS: UART RTS, goes HIGH to disable host transmitter. Low level output from RN41;
- VCC: 3.3V DC power supply; and
- GND: Ground.

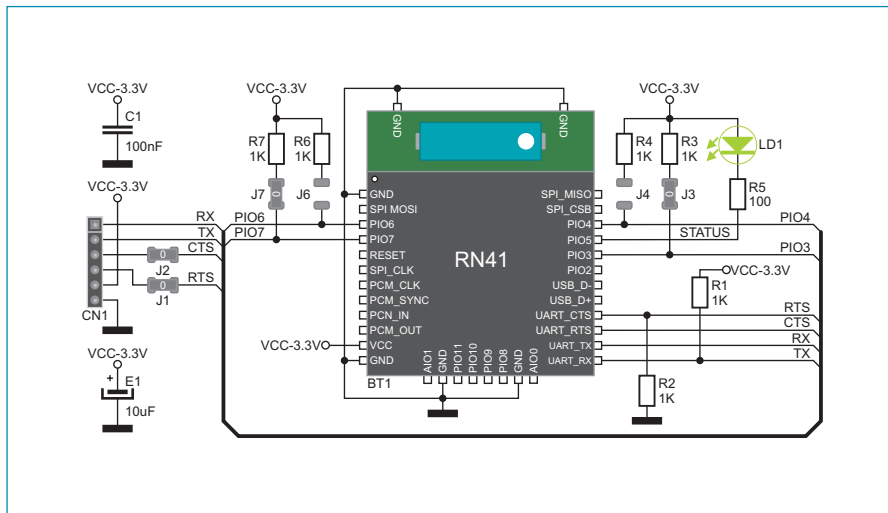

Figure 2: BlueTooth Stick connection schematic

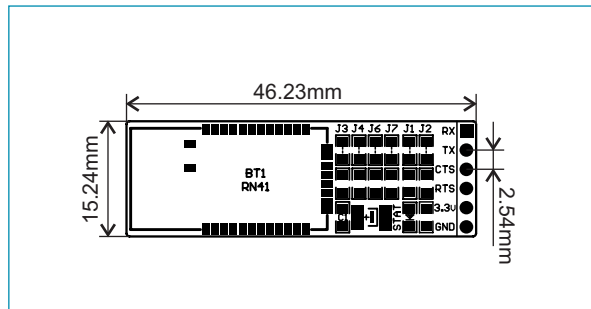

Figure 3: Dimensions of the Bluetooth Stick board

If you want to learn more about our products, please visit our website at www.mikroe.com

If you are experiencing some problems with any of our products or just need additional information, please place your ticket at www.mikroe.com/en/support

If you have any questions, comments or business proposals, do not hesitate to contact us at office@mikroe.com