



Chipsmall Limited consists of a professional team with an average of over 10 year of expertise in the distribution of electronic components. Based in Hongkong, we have already established firm and mutual-benefit business relationships with customers from,Europe,America and south Asia,supplying obsolete and hard-to-find components to meet their specific needs.

With the principle of "Quality Parts,Customers Priority,Honest Operation,and Considerate Service",our business mainly focus on the distribution of electronic components. Line cards we deal with include Microchip,ALPS,ROHM,Xilinx,Pulse,ON,Everlight and Freescale. Main products comprise IC,Modules,Potentiometer,IC Socket,Relay,Connector.Our parts cover such applications as commercial,industrial, and automotives areas.

We are looking forward to setting up business relationship with you and hope to provide you with the best service and solution. Let us make a better world for our industry!



Contact us

Tel: +86-755-8981 8866 Fax: +86-755-8427 6832

Email & Skype: info@chipsmall.com Web: www.chipsmall.com

Address: A1208, Overseas Decoration Building, #122 Zhenhua RD., Futian, Shenzhen, China



BUFFER/CLOCK DRIVER

MK3807-01

Description

The MK3807-01 is a low skew 3.3 V, 1 to 10 fanout buffer. The large fanout from a single input line reduces loading on the input clock. The TTL level outputs reduce noise levels on the part. Typical applications are clock and signal distribution.

Features

- Packaged in 20-pin SSOP
- Available in Pb (lead) free package
- 1 to 10 fanout buffer
- Maximum skew between outputs of same package 0.35 ns
- Maximum skew between outputs of different packages 0.75 ns
- Max propagation delay of 3.8 ns
- Operating voltage of 3.3 V
- Advanced, low power, CMOS process
- Industrial temperature range -40° C to +85° C
- Hysteresis on all inputs

NOTE: EOL for non-green parts to occur on 5/13/10 per PDN U-09-01

Block Diagram

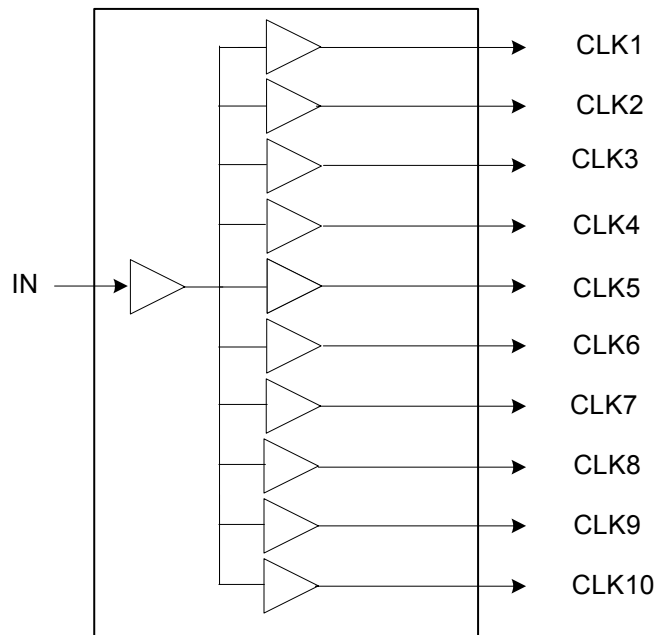

Pin Assignment

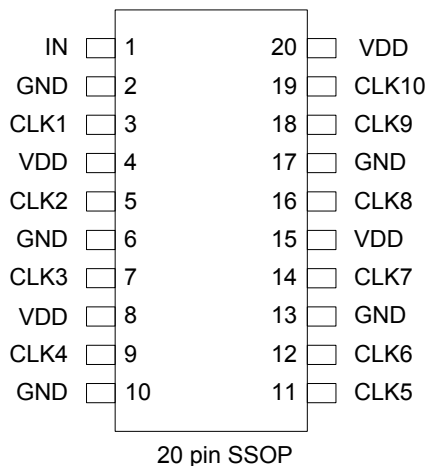

Pin Descriptions

Pin Number	Pin Name	Pin Type	Pin Description
1	IN	Input	Clock input.
2	GND	Power	Connect to ground.
3	CLK1	Output	Clock output.
4	VDD	Power	Connect to +3.3 V.
5	CLK2	Output	Clock output.
6	GND	Power	Connect to ground.
7	CLK3	Output	Clock output.
8	VDD	Power	Connect to +3.3 V.
9	CLK4	Output	Clock output.
10	GND	Power	Connect to ground.
11	CLK5	Output	Clock output.
12	CLK6	Output	Clock output.
13	GND	Power	Connect to ground.
14	CLK7	Output	Clock output.
15	VDD	Power	Connect to +3.3 V.
16	CLK8	Output	Clock output.
17	GND	Power	Connect to ground.
18	CLK9	Output	Clock output.
19	CLK10	Output	Clock output.
20	VDD	Power	Connect to +3.3 V.

External Components

The MK3807-01 requires a minimum number of external components for proper operation.

Decoupling Capacitors

Decoupling capacitors of 0.01 μ F must be connected between VDD and GND, as close to these pins as possible. For optimum device performance, the decoupling capacitors should be mounted on the component side of the PCB. Avoid the use of vias in the decoupling circuit.

Series Termination Resistor

When the PCB trace between the clock outputs and the loads are over 1 inch, series termination should be used. To series terminate a 50 Ω trace (a commonly used trace impedance) place a 33 Ω resistor in series with the clock line, as close to the clock output pin as possible. The nominal impedance of the clock output is 20 Ω .

PCB Layout Recommendations

For optimum device performance and lowest output phase noise, the following guidelines should be observed.

1) The 0.01 μ F decoupling capacitors should be mounted on the component side of the board as close to the VDD pins as possible. No vias should be used between the decoupling capacitors and VDD pins. The PCB trace to VDD pin should be kept as short as possible, as should the PCB trace to the ground via.

2) To minimize EMI, the 33 Ω series termination resistor, (if needed) should be placed close to the clock output.

Absolute Maximum Ratings

Stresses above the ratings listed below can cause permanent damage to the MK3807-01. These ratings, which are standard values for IDT commercially rated parts, are stress ratings only. Functional operation of the device at these or any other conditions above those indicated in the operational sections of the specifications is not implied. Exposure to absolute maximum rating conditions for extended periods can affect product reliability. Electrical parameters are guaranteed only over the recommended operating temperature range.

Item	Rating
Supply Voltage, VDD	7 V
All Inputs and Outputs	-0.5 V to VDD+0.5 V
Ambient Operating Temperature	-40 to +85° C
Storage Temperature	-65 to +150° C
Junction Temperature	125° C
Soldering Temperature	260° C

Recommended Operation Conditions

Parameter	Min.	Typ.	Max.	Units
Ambient Operating Temperature	-40		+85	°C
Power Supply Voltage (measured in respect to GND)	+3.135	+3.3	+3.465	V

DC Electrical Characteristics

Unless stated otherwise, $V_{DD} = 3.3 \text{ V} \pm 5\%$, Ambient Temperature -40° C to $+85^{\circ} \text{ C}$

Parameter	Symbol	Conditions	Min.	Typ.	Max.	Units
Operating Voltage	V_{DD}		3.135	3.3	3.465	V
Quiescent Power Supply Current	ICC	VCC=Max VIN=GND or VCC		3	30	μA
		VCC=Max VIN=@TTL HIGH (VCC-0.6 V)		2.0	300	μA
Input High Voltage	V_{IH}	High Level Input pins	2		5.5	V
Input Low Voltage	V_{IL}	Low Level Input pins	-0.5		0.8	V
Output High Voltage	V_{OH}	VCC=min VIN= V_{IH} or V_{IL} $I_{OH} = -0.1 \text{ mA}$, $I_{OH} = -8 \text{ mA}$	VDD-0.2 2.4	3.0		V
Output Low Voltage	V_{OL}	VCC=min VIN= V_{IH} or V_{IL} $I_{OL} = -0.1 \text{ mA}$, $I_{OL} = 16 \text{ mA}$ $I_{OL} = 24 \text{ mA}$			0.2 0.4 0.5	V
Short Circuit Current	I_{OS}	VCC=Max, $V_{OUT} = \text{GND}$	-60	-135	-240	mA
Input Capacitance	CIN	VIN=0V, Note1		5	6.0	pF
Output Capacitance	COUT	$V_{OUT} = 0\text{V}$, Note1		5.5	8.0	pF
Input Hysteresis	VH			150		mV

Note1: This parameter is not tested.

AC Electrical Characteristics

Unless stated otherwise, $V_{DD} = 3.3\text{ V} \pm 5\%$, Ambient Temperature -40° C to $+85^{\circ}\text{ C}$

Parameter	Symbol	Conditions	Min.	Typ.	Max.	Units
Skew between outputs of same package	$tsk_{g=(0)}$	$CL=50\text{ pF}$, $RL=500\Omega$			0.35	ns
Skew between opposite transitions of same output	$tsk_{(p)}$	$CL=50\text{ pF}$, $RL=500\Omega$			0.35	ns
Propagation Delay IN to ON	tp_{LH}/tp_{HL}	$CL=50\text{ pF}$, $RL=500\Omega$	1.5		3.8	ns
Skew between outputs of different package at same power supply, temperature and speed grade	$tsk_{(t)}$	$CL=50\text{ pF}$, $RL=500\Omega$			0.75	ns
Output Rise Time 0.8 V to 2.0 V	$tr_{(o)}$	$CL=50\text{ pF}$, $RL=500\Omega$			1.5	ns
Output Fall Time 2.0 V to 0.8 V	$tf_{(o)}$	$CL=50\text{ pF}$, $RL=500\Omega$			1.5	ns
Duty Cycle Measured at $V_{DD}/2$	DC	$CL=50\text{ pF}$, $RL=500\Omega$	45		55	%
Test Frequency			1		100	MHz

Package Outline and Package Dimensions (20 pin SSOP, 150Mil. Body)

Package dimensions are kept current with JEDEC Publication No. 95

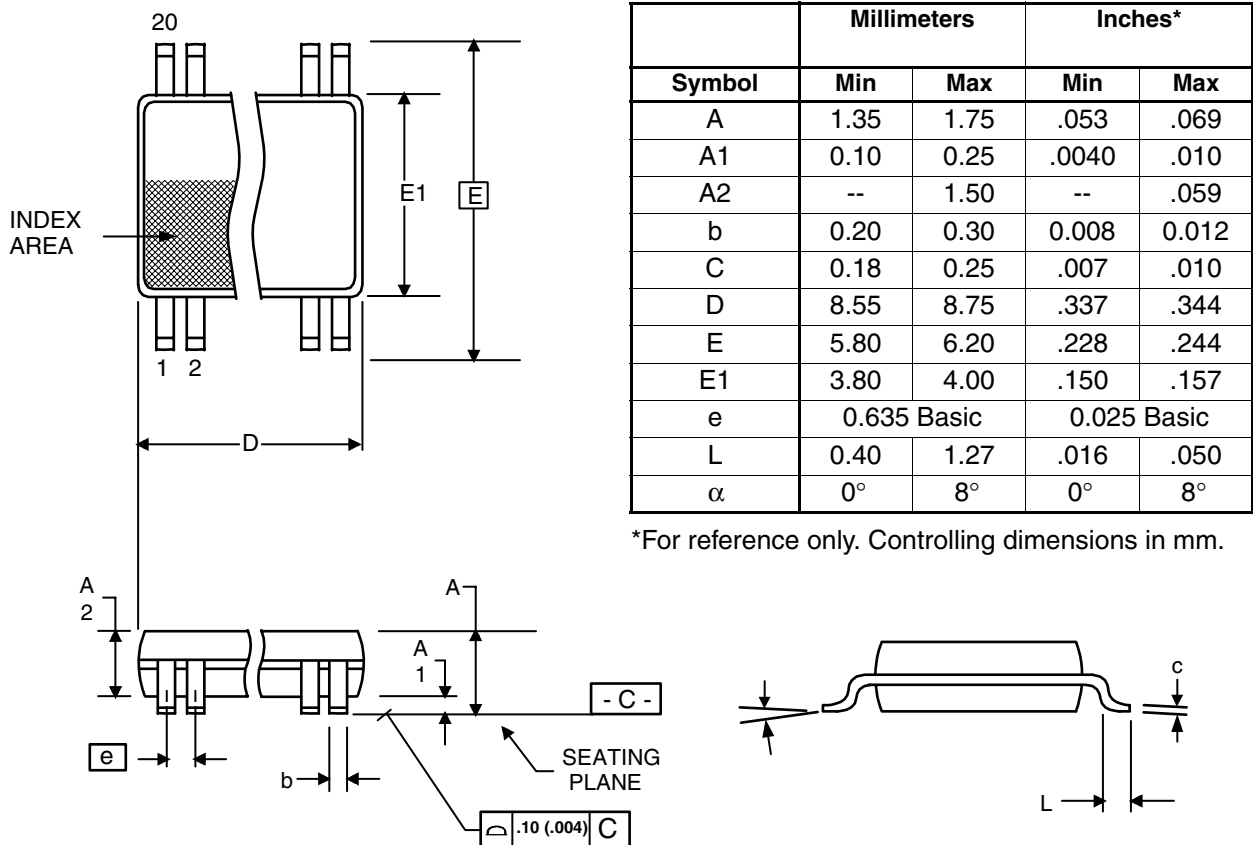

Ordering Information

Part / Order Number	Marking	Shipping Packaging	Package	Temperature
MK3807-01RI*	MK3807-01RI	Tubes	20-pin SSOP	-40 to +85° C
MK3807-01RITR*	MK3807-01RI	Tape and Reel	20-pin SSOP	-40 to +85° C
MK3807-01RILF	3807-01RILF	Tubes	20-pin SSOP	-40 to +85° C
MK3807-01RILFTR	3807-01RILF	Tape and Reel	20-pin SSOP	-40 to +85° C

*NOTE: EOL for non-green parts to occur on 5/13/10 per PDN U-09-01

Parts that are ordered with a "LF" suffix to the part number are the Pb-Free configuration and are RoHS compliant.

While the information presented herein has been checked for both accuracy and reliability, Integrated Device Technology (IDT) assumes no responsibility for either its use or for the infringement of any patents or other rights of third parties, which would result from its use. No other circuits, patents, or licenses are implied. This product is intended for use in normal commercial applications. Any other applications such as those requiring extended temperature range, high reliability, or other extraordinary environmental requirements are not recommended without additional processing by IDT. IDT reserves the right to change any circuitry or specifications without notice. IDT does not authorize or warrant any IDT product for use in life support devices or critical medical instruments.

Innovate with IDT and accelerate your future networks. Contact:

www.IDT.com

For Sales

800-345-7015
408-284-8200
Fax: 408-284-2775

For Tech Support

www.idt.com/go/clockhelp

Corporate Headquarters

Integrated Device Technology, Inc.
www.idt.com



www.IDT.com