



Chipsmall Limited consists of a professional team with an average of over 10 year of expertise in the distribution of electronic components. Based in Hongkong, we have already established firm and mutual-benefit business relationships with customers from,Europe,America and south Asia,supplying obsolete and hard-to-find components to meet their specific needs.

With the principle of "Quality Parts,Customers Priority,Honest Operation,and Considerate Service",our business mainly focus on the distribution of electronic components. Line cards we deal with include Microchip,ALPS,ROHM,Xilinx,Pulse,ON,Everlight and Freescale. Main products comprise IC,Modules,Potentiometer,IC Socket,Relay,Connector.Our parts cover such applications as commercial,industrial, and automotives areas.

We are looking forward to setting up business relationship with you and hope to provide you with the best service and solution. Let us make a better world for our industry!



Contact us

Tel: +86-755-8981 8866 Fax: +86-755-8427 6832

Email & Skype: info@chipsmall.com Web: www.chipsmall.com

Address: A1208, Overseas Decoration Building, #122 Zhenhua RD., Futian, Shenzhen, China



Kinetis KL43 Microcontroller

48 MHz ARM® Cortex®-M0+ and 128/256 KB Flash

MKL43Z256Vxx4(R)
MKL43Z128Vxx4(R)

The KL43 series is optimized for cost-sensitive and battery-powered applications requiring low-power USB connectivity and segment LCD. The product offers:

- Low power segment LCD up to 24x8 or 28x4
- USB FS 2.0 device without requiring an external crystal
- Embedded ROM with boot loader for flexible program upgrade
- High accuracy internal voltage and clock reference
- FlexIO to support any standard and customized serial peripheral emulation
- Down to 54uA/MHz in very low power run mode and 1.96uA in deep sleep mode (RAM + RTC retained)

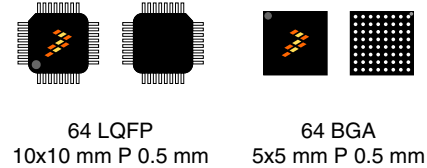

Core Processor

- ARM® Cortex®-M0+ core up to 48 MHz

Memories

- 128/256 KB program flash memory
- 16/32 KB SRAM
- 16 KB ROM with build-in bootloader
- 32-byte backup register

System

- 4-channel asynchronous DMA controller
- Watchdog
- Low-leakage wakeup unit
- Two-pin Serial Wire Debug (SWD) programming and debug interface
- Micro Trace Buffer
- Bit manipulation engine
- Interrupt controller

Clocks

- 48MHz high accuracy (up to 0.5%) internal reference clock
- 8MHz/2MHz high accuracy (up to 3%) internal reference clock
- 1KHz reference clock active under all low-power modes (except VLLS0)
- 32–40KHz and 3–32MHz crystal oscillator

Peripherals

- Segment LCD supporting up to 24x8 or 28x4 segments
- USB full-speed 2.0 device controller supporting crystal-less operation
- One UART module supporting ISO7816, operating up to 1.5 Mbit/s
- Two low-power UART modules supporting asynchronous operation in low-power modes
- Two I2C modules and I2C0 supporting up to 1 Mbit/s
- Two 16-bit SPI modules supporting up to 24 Mbit/s
- One FlexIO module supporting emulation of additional UART, SPI, I2C, I2S, PWM and other serial modules, etc.
- One serial audio interface I2S
- One 16-bit 818 kbps ADC module with high accuracy internal voltage reference (Vref) and up to 16 channels
- High-speed analog comparator containing a 6-bit DAC for programmable reference input
- One 12-bit DAC
- 1.2 V internal voltage reference

Operating Characteristics

- Voltage range: 1.71 to 3.6 V
- Flash write voltage range: 1.71 to 3.6 V
- Temperature range: -40 to 105 °C

Packages

- 64 LQFP 10mm x 10mm, 0.5mm pitch, 1.6mm thickness
- 64 MAPBGA 5mm x 5mm, 0.5mm pitch, 1.23mm thickness

Low Power

- Down to 54uA/MHz in very low power run mode
- Down to 1.96uA in VLLS3 mode (RAM + RTC retained)
- Six flexible static modes

Timers

- One 6-channel Timer/PWM module
- Two 2-channel Timer/PWM modules
- One low-power timer
- Periodic interrupt timer
- Real time clock

Security and Integrity

- 80-bit unique identification number per chip
- Advanced flash security

I/O

- Up to 50 general-purpose input/output pins (GPIO) and 6 high-drive pad

Ordering Information

Product		Memory		Package		IO and ADC channel		
Part number	Marking (Line1/Line2)	Flash (KB)	SRAM (KB)	Pin count	Package	GPIOs	GPIOs (INT/HD) ¹	ADC channels (SE/DP)
MKL43Z128VLH4	MKL43Z128V//LH4	128	16	64	LQFP	50	31/6	16/2
MKL43Z256VLH4	MKL43Z256V//LH4	256	32	64	LQFP	50	31/6	16/2
MKL43Z128VMP4	M43P7V	128	16	64	MAPBGA	50	31/6	16/2
MKL43Z256VMP4	M43P8V	256	32	64	MAPBGA	50	31/6	16/2

1. INT: interrupt pin numbers; HD: high drive pin numbers

Related Resources

Type	Description	Resource
Selector Guide	The Freescale Solution Advisor is a web-based tool that features interactive application wizards and a dynamic product selector.	Solution Advisor
Product Brief	The Product Brief contains concise overview/summary information to enable quick evaluation of a device for design suitability.	KLX3PB ¹
Reference Manual	The Reference Manual contains a comprehensive description of the structure and function (operation) of a device.	KL43P64M48SF6RM ¹
Data Sheet	The Data Sheet includes electrical characteristics and signal connections.	This document.
Chip Errata	The chip mask set Errata provides additional or corrective information for a particular device mask set.	KINETIS_L_1N71K ¹
Package drawing	Package dimensions are provided in package drawings.	64-LQFP: 98ASS23234W ¹ 64 MAPBGA: 98ASA00420D ¹

1. To find the associated resource, go to <http://www.freescale.com> and perform a search using this term.



Table of Contents

1 Ratings.....	4	3.6.2 Voltage reference electrical specifications.....	35
1.1 Thermal handling ratings.....	4	3.6.3 CMP and 6-bit DAC electrical specifications.....	36
1.2 Moisture handling ratings.....	4	3.6.4 12-bit DAC electrical characteristics.....	38
1.3 ESD handling ratings.....	4	3.7 Timers.....	41
1.4 Voltage and current operating ratings.....	4	3.8 Communication interfaces.....	41
2 General.....	5	3.8.1 USB electrical specifications.....	41
2.1 AC electrical characteristics.....	5	3.8.2 USB VREG electrical specifications.....	42
2.2 Nonswitching electrical specifications.....	6	3.8.3 SPI switching specifications.....	42
2.2.1 Voltage and current operating requirements.....	6	3.8.4 I2C.....	47
2.2.2 LVD and POR operating requirements.....	6	3.8.5 UART.....	49
2.2.3 Voltage and current operating behaviors.....	7	3.8.6 I2S/SAI switching specifications.....	49
2.2.4 Power mode transition operating behaviors.....	8	3.9 Human-machine interfaces (HMI).....	53
2.2.5 Power consumption operating behaviors.....	9	3.9.1 LCD electrical characteristics.....	53
2.2.6 EMC radiated emissions operating behaviors...	19	4 Dimensions.....	55
2.2.7 Designing with radiated emissions in mind.....	20	4.1 Obtaining package dimensions.....	55
2.2.8 Capacitance attributes.....	20	5 Pinouts and Packaging.....	55
2.3 Switching specifications.....	20	5.1 KL43 Signal Multiplexing and Pin Assignments.....	55
2.3.1 Device clock specifications.....	20	5.2 KL43 Family Pinouts.....	58
2.3.2 General switching specifications.....	21	6 Ordering parts.....	60
2.4 Thermal specifications.....	21	6.1 Determining valid orderable parts.....	60
2.4.1 Thermal operating requirements.....	21	7 Part identification.....	60
2.4.2 Thermal attributes.....	22	7.1 Description.....	60
3 Peripheral operating requirements and behaviors.....	22	7.2 Format.....	61
3.1 Core modules.....	22	7.3 Fields.....	61
3.1.1 SWD electricals	23	7.4 Example.....	61
3.2 System modules.....	24	8 Terminology and guidelines.....	62
3.3 Clock modules.....	24	8.1 Definitions.....	62
3.3.1 MCG-Lite specifications.....	24	8.2 Examples.....	62
3.3.2 Oscillator electrical specifications.....	26	8.3 Typical-value conditions.....	63
3.4 Memories and memory interfaces.....	28	8.4 Relationship between ratings and operating requirements.....	63
3.4.1 Flash electrical specifications.....	28	8.5 Guidelines for ratings and operating requirements.....	64
3.5 Security and integrity modules.....	30	9 Revision History.....	64
3.6 Analog.....	30		
3.6.1 ADC electrical specifications.....	30		

1 Ratings

1.1 Thermal handling ratings

Table 1. Thermal handling ratings

Symbol	Description	Min.	Max.	Unit	Notes
T _{STG}	Storage temperature	-55	150	°C	1
T _{SDR}	Solder temperature, lead-free	—	260	°C	2

1. Determined according to JEDEC Standard JESD22-A103, *High Temperature Storage Life*.
2. Determined according to IPC/JEDEC Standard J-STD-020, *Moisture/Reflow Sensitivity Classification for Nonhermetic Solid State Surface Mount Devices*.

1.2 Moisture handling ratings

Table 2. Moisture handling ratings

Symbol	Description	Min.	Max.	Unit	Notes
MSL	Moisture sensitivity level	—	3	—	1

1. Determined according to IPC/JEDEC Standard J-STD-020, *Moisture/Reflow Sensitivity Classification for Nonhermetic Solid State Surface Mount Devices*.

1.3 ESD handling ratings

Table 3. ESD handling ratings

Symbol	Description	Min.	Max.	Unit	Notes
V _{HBM}	Electrostatic discharge voltage, human body model	-2000	+2000	V	1
V _{CDM}	Electrostatic discharge voltage, charged-device model	-500	+500	V	2
I _{LAT}	Latch-up current at ambient temperature of 105 °C	-100	+100	mA	3

1. Determined according to JEDEC Standard JESD22-A114, *Electrostatic Discharge (ESD) Sensitivity Testing Human Body Model (HBM)*.
2. Determined according to JEDEC Standard JESD22-C101, *Field-Induced Charged-Device Model Test Method for Electrostatic-Discharge-Withstand Thresholds of Microelectronic Components*.
3. Determined according to JEDEC Standard JESD78, *IC Latch-Up Test*.

1.4 Voltage and current operating ratings

Table 4. Voltage and current operating ratings

Symbol	Description	Min.	Max.	Unit
V_{DD}	Digital supply voltage	-0.3	3.8	V
I_{DD}	Digital supply current	—	120	mA
V_{IO}	IO pin input voltage	-0.3	$V_{DD} + 0.3$	V
I_D	Instantaneous maximum current single pin limit (applies to all port pins)	-25	25	mA
V_{DDA}	Analog supply voltage	$V_{DD} - 0.3$	$V_{DD} + 0.3$	V
V_{USB_DP}	USB_DP input voltage	-0.3	3.63	V
V_{USB_DM}	USB_DM input voltage	-0.3	3.63	V
V_{REGIN}	USB regulator input	-0.3	6.0	V

2 General

2.1 AC electrical characteristics

Unless otherwise specified, propagation delays are measured from the 50% to the 50% point, and rise and fall times are measured at the 20% and 80% points, as shown in the following figure.

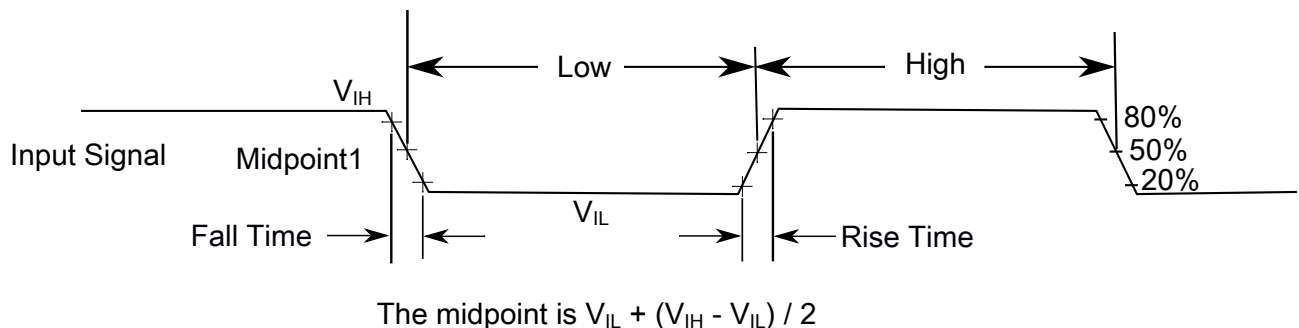

Figure 1. Input signal measurement reference

All digital I/O switching characteristics, unless otherwise specified, assume that the output pins have the following characteristics.

- $C_L=30$ pF loads
- Slew rate disabled
- Normal drive strength

2.2 Nonswitching electrical specifications

2.2.1 Voltage and current operating requirements

Table 5. Voltage and current operating requirements

Symbol	Description	Min.	Max.	Unit	Notes
V _{DD}	Supply voltage	1.71	3.6	V	
V _{DDA}	Analog supply voltage	1.71	3.6	V	
V _{DD} - V _{DDA}	V _{DD} -to-V _{DDA} differential voltage	-0.1	0.1	V	
V _{SS} - V _{SSA}	V _{SS} -to-V _{SSA} differential voltage	-0.1	0.1	V	
V _{IH}	Input high voltage <ul style="list-style-type: none"> • 2.7 V ≤ V_{DD} ≤ 3.6 V • 1.7 V ≤ V_{DD} ≤ 2.7 V 	0.7 × V _{DD} 0.75 × V _{DD}	— —	V V	
V _{IL}	Input low voltage <ul style="list-style-type: none"> • 2.7 V ≤ V_{DD} ≤ 3.6 V • 1.7 V ≤ V_{DD} ≤ 2.7 V 	— —	0.35 × V _{DD} 0.3 × V _{DD}	V V	
V _{HYS}	Input hysteresis	0.06 × V _{DD}	—	V	
I _{ICIO}	IO pin negative DC injection current — single pin <ul style="list-style-type: none"> • V_{IN} < V_{SS}-0.3V 	-3	—	mA	1
I _{ICcont}	Contiguous pin DC injection current —regional limit, includes sum of negative injection currents of 16 contiguous pins <ul style="list-style-type: none"> • Negative current injection 	-25	—	mA	
V _{ODPU}	Open drain pullup voltage level	V _{DD}	V _{DD}	V	2
V _{RAM}	V _{DD} voltage required to retain RAM	1.2	—	V	

1. All I/O pins are internally clamped to V_{SS} through a ESD protection diode. There is no diode connection to V_{DD}. If V_{IN} greater than V_{IO_MIN} (= V_{SS}-0.3 V) is observed, then there is no need to provide current limiting resistors at the pads. If this limit cannot be observed then a current limiting resistor is required. The negative DC injection current limiting resistor is calculated as R = (V_{IO_MIN} - V_{IN})/|I_{ICIO}|.
2. Open drain outputs must be pulled to V_{DD}.

2.2.2 LVD and POR operating requirements

Table 6. V_{DD} supply LVD and POR operating requirements

Symbol	Description	Min.	Typ.	Max.	Unit	Notes
V _{POR}	Falling V _{DD} POR detect voltage	0.8	1.1	1.5	V	—

Table continues on the next page...

Table 6. V_{DD} supply LVD and POR operating requirements (continued)

Symbol	Description	Min.	Typ.	Max.	Unit	Notes
V _{LVDH}	Falling low-voltage detect threshold — high range (LVDV = 01)	2.48	2.56	2.64	V	—
V _{LVW1H}	Low-voltage warning thresholds — high range <ul style="list-style-type: none"> • Level 1 falling (LVWV = 00) • Level 2 falling (LVWV = 01) • Level 3 falling (LVWV = 10) • Level 4 falling (LVWV = 11) 	2.62	2.70	2.78	V	1
V _{LVW2H}		2.72	2.80	2.88	V	
V _{LVW3H}		2.82	2.90	2.98	V	
V _{LVW4H}		2.92	3.00	3.08	V	
V _{HYSH}	Low-voltage inhibit reset/recover hysteresis — high range	—	±60	—	mV	—
V _{LVDL}	Falling low-voltage detect threshold — low range (LVDV=00)	1.54	1.60	1.66	V	—
V _{LVW1L}	Low-voltage warning thresholds — low range <ul style="list-style-type: none"> • Level 1 falling (LVWV = 00) • Level 2 falling (LVWV = 01) • Level 3 falling (LVWV = 10) • Level 4 falling (LVWV = 11) 	1.74	1.80	1.86	V	1
V _{LVW2L}		1.84	1.90	1.96	V	
V _{LVW3L}		1.94	2.00	2.06	V	
V _{LVW4L}		2.04	2.10	2.16	V	
V _{HYSL}	Low-voltage inhibit reset/recover hysteresis — low range	—	±40	—	mV	—
V _{BG}	Bandgap voltage reference	0.97	1.00	1.03	V	—
t _{LPO}	Internal low power oscillator period — factory trimmed	900	1000	1100	µs	—

1. Rising thresholds are falling threshold + hysteresis voltage

2.2.3 Voltage and current operating behaviors

Table 7. Voltage and current operating behaviors

Symbol	Description	Min.	Max.	Unit	Notes
V _{OH}	Output high voltage — normal drive pad <ul style="list-style-type: none"> • 2.7 V ≤ V_{DD} ≤ 3.6 V, I_{OH} = -5 mA • 1.71 V ≤ V_{DD} ≤ 2.7 V, I_{OH} = -1.5 mA 	V _{DD} - 0.5	—	V	1
		V _{DD} - 0.5	—	V	
V _{OH}	Output high voltage — high drive pad <ul style="list-style-type: none"> • 2.7 V ≤ V_{DD} ≤ 3.6 V, I_{OH} = -18 mA • 1.71 V ≤ V_{DD} ≤ 2.7 V, I_{OH} = -6 mA 	V _{DD} - 0.5	—	V	1
		V _{DD} - 0.5	—	V	
I _{OHT}	Output high current total for all ports	—	100	mA	
V _{OL}	Output low voltage — normal drive pad	—	0.5	V	1

Table continues on the next page...

Table 7. Voltage and current operating behaviors (continued)

Symbol	Description	Min.	Max.	Unit	Notes
	<ul style="list-style-type: none"> • $2.7\text{ V} \leq V_{DD} \leq 3.6\text{ V}$, $I_{OL} = 5\text{ mA}$ • $1.71\text{ V} \leq V_{DD} \leq 2.7\text{ V}$, $I_{OL} = 1.5\text{ mA}$ 	—	0.5	V	
V_{OL}	Output low voltage — high drive pad <ul style="list-style-type: none"> • $2.7\text{ V} \leq V_{DD} \leq 3.6\text{ V}$, $I_{OL} = 18\text{ mA}$ • $1.71\text{ V} \leq V_{DD} \leq 2.7\text{ V}$, $I_{OL} = 6\text{ mA}$ 	—	0.5	V	1
		—	0.5	V	
I_{OLT}	Output low current total for all ports	—	100	mA	
I_{IN}	Input leakage current (per pin) for full temperature range	—	1	μA	2
I_{IN}	Input leakage current (per pin) at 25 °C	—	0.025	μA	2
I_{IN}	Input leakage current (total all pins) for full temperature range	—	64	μA	2
I_{OZ}	Hi-Z (off-state) leakage current (per pin)	—	1	μA	
R_{PU}	Internal pullup resistors	20	50	k Ω	3

1. PTB0, PTB1, PTC3, PTC4, PTD6, and PTD7 I/O have both high drive and normal drive capability selected by the associated PTx_PCRn[DSE] control bit. All other GPIOs are normal drive only.
2. Measured at $V_{DD} = 3.6\text{ V}$
3. Measured at V_{DD} supply voltage = V_{DD} min and $V_{input} = V_{SS}$

2.2.4 Power mode transition operating behaviors

All specifications except t_{POR} and $VLLSx \rightarrow \text{RUN}$ recovery times in the following table assume this clock configuration:

- CPU and system clocks = 48 MHz
- Bus and flash clock = 24 MHz
- HIRC clock mode

Table 8. Power mode transition operating behaviors

Symbol	Description	Min.	Typ.	Max.	Unit	Notes
t_{POR}	After a POR event, amount of time from the point V_{DD} reaches 1.8 V to execution of the first instruction across the operating temperature range of the chip.	—	—	300	μs	1
	<ul style="list-style-type: none"> • $VLLS0 \rightarrow \text{RUN}$ 	—	152	166	μs	
	<ul style="list-style-type: none"> • $VLLS1 \rightarrow \text{RUN}$ 	—	152	166	μs	
	<ul style="list-style-type: none"> • $VLLS3 \rightarrow \text{RUN}$ 	—	93	104	μs	

Table continues on the next page...

Table 8. Power mode transition operating behaviors (continued)

Symbol	Description	Min.	Typ.	Max.	Unit	Notes
	• LLS → RUN	—	7.5	8	μs	
	• VLPS → RUN	—	7.5	8	μs	
	• STOP → RUN	—	7.5	8	μs	

1. Normal boot (FTFA_FOFT[LPBOOT]=11)

2.2.5 Power consumption operating behaviors

The maximum values stated in the following table represent characterized results equivalent to the mean plus three times the standard deviation (mean + 3 sigma).

NOTE

The while (1) test is executed with flash cache enabled.

Table 9. Power consumption operating behaviors

Symbol	Description	Min.	Typ.	Max.	Unit	Notes
I _{DDA}	Analog supply current	—	—	See note	mA	1
I _{DD_RUNCO}	Running CoreMark in flash in compute operation mode—48M HIRC mode, 48 MHz core / 24 MHz flash, V _{DD} = 3.0 V <ul style="list-style-type: none"> • at 25 °C • at 105 °C 	— —	5.76 6.04	6.40 6.68	mA	2
I _{DD_RUNCO}	Running While(1) loop in flash in compute operation mode—48M HIRC mode, 48 MHz core / 24 MHz flash, V _{DD} = 3.0 V <ul style="list-style-type: none"> • at 25 °C • at 105 °C 	— —	3.21 3.49	3.85 4.13	mA	
I _{DD_RUN}	Run mode current—48M HIRC mode, running CoreMark in Flash all peripheral clock disable 48 MHz core/24 MHz flash, V _{DD} = 3.0 V <ul style="list-style-type: none"> • at 25 °C • at 105 °C 	— —	6.45 6.75	7.09 7.39	mA	2
I _{DD_RUN}	Run mode current—48M HIRC mode, running CoreMark in flash all peripheral clock disable, 24 MHz core/12 MHz flash, V _{DD} = 3.0 V	— —	3.95 4.23	4.59 4.87	mA	2

Table continues on the next page...

Table 9. Power consumption operating behaviors (continued)

Symbol	Description	Min.	Typ.	Max.	Unit	Notes
	<ul style="list-style-type: none"> at 25 °C at 105 °C 					
I _{DD_RUN}	Run mode current—48M HIRC mode, running CoreMark in Flash all peripheral clock disable 12 MHz core/6 MHz flash, V _{DD} = 3.0 V <ul style="list-style-type: none"> at 25 °C at 105 °C 	—	2.68	3.32	mA	2
I _{DD_RUN}	Run mode current—48M HIRC mode, running CoreMark in Flash all peripheral clock enable 48 MHz core/24 MHz flash, V _{DD} = 3.0 V <ul style="list-style-type: none"> at 25 °C at 105 °C 	—	8.08	8.72	mA	2
I _{DD_RUN}	Run mode current—48M HIRC mode, running While(1) loop in flash all peripheral clock disable, 48 MHz core/24 MHz flash, V _{DD} = 3.0 V <ul style="list-style-type: none"> at 25 °C at 105 °C 	—	3.90	4.54	mA	
I _{DD_RUN}	Run mode current—48M HIRC mode, running While(1) loop in Flash all peripheral clock disable, 24 MHz core/12 MHz flash, V _{DD} = 3.0 V <ul style="list-style-type: none"> at 25 °C at 105 °C 	—	2.66	3.30	mA	
I _{DD_RUN}	Run mode current—48M HIRC mode, Running While(1) loop in Flash all peripheral clock disable, 12 MHz core/6 MHz flash, V _{DD} = 3.0 V <ul style="list-style-type: none"> at 25 °C at 105 °C 	—	2.03	2.67	mA	
I _{DD_RUN}	Run mode current—48M HIRC mode, Running While(1) loop in Flash all peripheral clock enable, 48 MHz core/24 MHz flash, V _{DD} = 3.0 V <ul style="list-style-type: none"> at 25 °C at 105 °C 	—	5.52	6.16	mA	
I _{DD_RUN}	Run mode current—48M HIRC mode, running While(1) loop in SRAM all peripheral clock disable, 48 MHz core/24 MHz flash, V _{DD} = 3.0 V <ul style="list-style-type: none"> at 25 °C at 105 °C 	—	5.29	5.93	mA	
I _{DD_RUN}	Run mode current—48M HIRC mode, running While(1) loop in SRAM all peripheral clock enable, 48 MHz core/24 MHz flash, V _{DD} = 3.0 V <ul style="list-style-type: none"> at 25 °C at 105 °C 	—	6.91	7.55	mA	

Table continues on the next page...

Table 9. Power consumption operating behaviors (continued)

Symbol	Description	Min.	Typ.	Max.	Unit	Notes
	<ul style="list-style-type: none"> at 25 °C at 105 °C 					
I _{DD_VLPRC} O	Very Low Power Run Core Mark in Flash in Compute Operation mode: Core@4MHz, Flash @1MHz, V _{DD} = 3.0 V <ul style="list-style-type: none"> at 25 °C 	—	826	907	μA	
I _{DD_VLPRC} O	Very-low-power-run While(1) loop in SRAM in compute operation mode— 8 MHz LIRC mode, 4 MHz core / 1 MHz flash, V _{DD} = 3.0 V <ul style="list-style-type: none"> at 25 °C 	—	405	486	μA	
I _{DD_VLPRC} O	Very-low-power run While(1) loop in SRAM in compute operation mode:—2 MHz LIRC mode, 2 MHz core / 0.5 MHz flash, V _{DD} = 3.0 V <ul style="list-style-type: none"> at 25 °C 	—	154	235	μA	
I _{DD_VLPR}	Very-low-power run mode current— 2 MHz LIRC mode, While(1) loop in flash all peripheral clock disable, 2 MHz core / 0.5 MHz flash, V _{DD} = 3.0 V <ul style="list-style-type: none"> at 25 °C 	—	108	189	μA	
I _{DD_VLPR}	Very-low-power run mode current— 2 MHz LIRC mode, While(1) loop in flash all peripheral clock disable, 125 kHz core / 31.25 kHz flash, V _{DD} = 3.0 V <ul style="list-style-type: none"> at 25 °C 	—	39	120	μA	
I _{DD_VLPR}	Very-low-power run mode current— 8 MHz LIRC mode, While(1) loop in flash all peripheral clock disable, 4 MHz core / 1 MHz flash, V _{DD} = 3.0 V <ul style="list-style-type: none"> at 25 °C 	—	249	330	μA	
I _{DD_VLPR}	Very-low-power run mode current— 8 MHz LIRC mode, While(1) loop in flash all peripheral clock enable, 4 MHz core / 1 MHz flash, V _{DD} = 3.0 V <ul style="list-style-type: none"> at 25 °C 	—	337	418	μA	
I _{DD_VLPR}	Very-low-power run mode current— 8 MHz LIRC mode, While(1) loop in SRAM in all peripheral clock disable, 4 MHz core / 1 MHz flash, V _{DD} = 3.0 V <ul style="list-style-type: none"> at 25 °C 	—	416	497	μA	
I _{DD_VLPR}	Very-low-power run mode current— 8 MHz LIRC mode, While(1) loop in SRAM all peripheral clock enable, 4 MHz core / 1 MHz flash, V _{DD} = 3.0 V <ul style="list-style-type: none"> at 25 °C 	—	494	575	μA	
I _{DD_VLPR}	Very-low-power run mode current—2 MHz LIRC mode, While(1) loop in SRAM in all peripheral clock disable, 2 MHz core / 0.5 MHz flash, V _{DD} = 3.0 V <ul style="list-style-type: none"> at 25 °C 	—	166	247	μA	
I _{DD_VLPR}	Very-low-power run mode current—2 MHz LIRC mode, While(1) loop in SRAM all peripheral clock					

Table continues on the next page...

Table 9. Power consumption operating behaviors (continued)

Symbol	Description	Min.	Typ.	Max.	Unit	Notes
	disable, 125 kHz core / 31.25 kHz flash, $V_{DD} = 3.0\text{ V}$ <ul style="list-style-type: none"> at 25 °C 	—	50	131	μA	
I_{DD_VLPR}	Very-low-power run mode current—2 MHz LIRC mode, While(1) loop in SRAM all peripheral clock enable, 2 MHz core / 0.5 MHz flash, $V_{DD} = 3.0\text{ V}$ <ul style="list-style-type: none"> at 25 °C 	—	208	289	μA	
I_{DD_WAIT}	Wait mode current—core disabled, 48 MHz system/24 MHz bus, flash disabled (flash doze enabled), all peripheral clocks disabled, MCG_Lite under HIRC mode, $V_{DD} = 3.0\text{ V}$	—	1.81	1.89	mA	
I_{DD_WAIT}	Wait mode current—core disabled, 24 MHz system/12 MHz bus, flash disabled (flash doze enabled), all peripheral clocks disabled, MCG_Lite under HIRC mode, $V_{DD} = 3.0\text{ V}$	—	1.22	1.39	mA	
I_{DD_VLPW}	Very-low-power wait mode current, core disabled, 4 MHz system/ 1 MHz bus and flash, all peripheral clocks disabled, $V_{DD} = 3.0\text{ V}$	—	172	182	μA	
I_{DD_VLPW}	Very-low-power wait mode current, core disabled, 2 MHz system/ 0.5 MHz bus and flash, all peripheral clocks disabled, $V_{DD} = 3.0\text{ V}$	—	69	76	μA	
I_{DD_VLPW}	Very-low-power wait mode current, core disabled, 125 kHz system/ 31.25 kHz bus and flash, all peripheral clocks disabled, $V_{DD} = 3.0\text{ V}$	—	36	40	μA	
I_{DD_PSTOP2}	Partial Stop 2, core and system clock disabled, 12 MHz bus and flash, $V_{DD} = 3.0\text{ V}$	—	1.81	2.06	mA	
I_{DD_PSTOP2}	Partial Stop 2, core and system clock disabled, flash doze enabled, 12 MHz bus, $V_{DD} = 3.0\text{ V}$	—	1.00	1.25	mA	
I_{DD_STOP}	Stop mode current at 3.0 V <ul style="list-style-type: none"> at 25 °C and below at 50 °C at 85 °C at 105 °C 	—	161.93	171.82	μA	
		—	181.45	191.96		
		—	236.29	271.17		
		—	390.33	465.58		
I_{DD_VLPS}	Very-low-power stop mode current at 3.0 V <ul style="list-style-type: none"> at 25 °C and below at 50 °C at 85 °C at 105 °C 	—	3.31	5.14	μA	
		—	10.43	17.68		
		—	34.14	61.06		
		—	104.38	164.44		
I_{DD_VLPS}	Very-low-power stop mode current at 1.8 V <ul style="list-style-type: none"> at 25 °C and below 	—	3.21	5.22		

Table continues on the next page...

Table 9. Power consumption operating behaviors (continued)

Symbol	Description	Min.	Typ.	Max.	Unit	Notes	
	<ul style="list-style-type: none"> • at 50 °C • at 85 °C • at 105 °C 	—	10.26	17.62	μA		
		—	33.49	60.19			
		—	102.92	162.20			
I _{DD_ULLS}	Low-leakage stop mode current, all peripheral disable, at 3.0 V <ul style="list-style-type: none"> • at 25 °C and below • at 50 °C • at 70 °C • at 85 °C • at 105 °C 	—	2.06	3.33	μA		
		—	4.72	6.85			
		—	8.13	13.30			
		—	13.34	24.70			
		—	41.08	52.43			
I _{DD_ULLS}	Low-leakage stop mode current with RTC current, at 3.0 V <ul style="list-style-type: none"> • at 25 °C and below • at 50 °C • at 70 °C • at 85 °C • at 105 °C 	—	2.46	3.73	μA		
		—	5.12	7.25			
		—	8.53	11.78			
		—	13.74	18.91			
		—	41.48	52.83			
I _{DD_ULLS}	Low-leakage stop mode current with RTC current, at 1.8 V <ul style="list-style-type: none"> • at 25 °C and below • at 50 °C • at 70 °C • at 85 °C • at 105 °C 	—	2.35	2.70	μA	3	
		—	4.91	6.75			
		—	8.32	11.78			
		—	13.44	18.21			
		—	40.47	51.85			
I _{DD_VLLS3}	Very-low-leakage stop mode 3 current, all peripheral disable, at 3.0 V <ul style="list-style-type: none"> • at 25 °C and below • at 50 °C • at 70 °C • at 85 °C • at 105 °C 	—	1.45	1.85	μA		
		—	3.37	4.39			
		—	5.76	8.48			
		—	9.72	14.30			
		—	30.41	37.50			
I _{DD_VLLS3}	Very-low-leakage stop mode 3 current with RTC current, at 3.0 V <ul style="list-style-type: none"> • at 25 °C and below • at 50 °C • at 70 °C • at 85 °C • at 105 °C 	—	2.05	2.45	μA	3	
		—	3.97	4.99			
		—	6.36	9.08			
		—	10.32	14.73			
		—	31.01	38.10			

Table continues on the next page...

Table 9. Power consumption operating behaviors (continued)

Symbol	Description	Min.	Typ.	Max.	Unit	Notes
I _{DD_VLLS3}	Very-low-leakage stop mode 3 current with RTC current, at 1.8 V <ul style="list-style-type: none"> • at 25 °C and below • at 50 °C • at 70 °C • at 85 °C • at 105 °C 	—	1.96	2.36	μA	3
I _{DD_VLLS1}	Very-low-leakage stop mode 1 current all peripheral disabled at 3.0 V <ul style="list-style-type: none"> • at 25 °C and below • at 50 °C • at 70 °C • at 85 °C • at 105 °C 	—	0.66	0.80	μA	
I _{DD_VLLS1}	Very-low-leakage stop mode 1 current RTC enabled at 3.0 V <ul style="list-style-type: none"> • at 25 °C and below • at 50 °C • at 70 °C • at 85 °C • at 105 °C 	—	1.26	1.40	μA	3
I _{DD_VLLS1}	Very-low-leakage stop mode 1 current RTC enabled at 1.8 V <ul style="list-style-type: none"> • at 25 °C and below • at 50 °C • at 70 °C • at 85 °C • at 105 °C 	—	1.16	1.30	μA	3
I _{DD_VLLS0}	Very-low-leakage stop mode 0 current all peripheral disabled (SMC_STOPCTRL[PORPO] = 0) at 3.0 V <ul style="list-style-type: none"> • at 25 °C and below • at 50 °C • at 70 °C • at 85 °C • at 105 °C 	—	0.35	0.47	μA	
I _{DD_VLLS0}	Very-low-leakage stop mode 0 current all peripheral disabled (SMC_STOPCTRL[PORPO] = 1) at 3 V					

Table 9. Power consumption operating behaviors

Symbol	Description	Min.	Typ.	Max.	Unit	Notes
	<ul style="list-style-type: none"> at 25 °C and below at 50 °C at 70 °C at 85 °C at 105 °C 	—	0.18	0.28	μA	
		—	1.09	1.31		
		—	2.25	2.94		
		—	4.25	5.10		
		—	15.95	19.10		

1. The analog supply current is the sum of the active or disabled current for each of the analog modules on the device. See each module's specification for its supply current.
2. MCG_Lite configured for HIRC mode. CoreMark benchmark compiled using IAR 7.10 with optimization level high, optimized for balanced.
3. RTC uses external 32 kHz crystal as clock source, and the current includes ERCLK32K power consumption.

Table 10. Low power mode peripheral adders — typical value

Symbol	Description	Temperature (°C)						Unit
		-40	25	50	70	85	105	
I _{IRC8MHz}	8 MHz internal reference clock (IRC) adder. Measured by entering STOP or VLPS mode with 8 MHz IRC enabled, MCG_SC[FCRDIV]=000b, MCG_MC[LIRC_DIV2]=000b.	93	93	93	93	93	93	μA
I _{IRC2MHz}	2 MHz internal reference clock (IRC) adder. Measured by entering STOP mode with the 2 MHz IRC enabled, MCG_SC[FCRDIV]=000b, MCG_MC[LIRC_DIV2]=000b.	29	29	29	29	29	29	μA
I _{EREFSTEN4MHz}	External 4 MHz crystal clock adder. Measured by entering STOP or VLPS mode with the crystal enabled.	206	224	230	238	245	253	μA
I _{EREFSTEN32KHz}	External 32 kHz crystal clock adder by means of the OSC0_CR[EREFSTEN and EREFSTEN] bits. Measured by entering all modes with the crystal enabled. <ul style="list-style-type: none"> VLLS1 VLLS3 LLS VLPS STOP 	440	490	540	560	570	580	nA
		440	490	540	560	570	580	
		490	490	540	560	570	680	
		510	560	560	560	610	680	
		510	560	560	560	610	680	
I _{LPTMR}	LPTMR peripheral adder measured by placing the device in VLLS1 mode with LPTMR enabled using LPO.	30	30	30	85	100	200	

Table continues on the next page...

Table 10. Low power mode peripheral adders — typical value (continued)

Symbol	Description	Temperature (°C)						Unit
		-40	25	50	70	85	105	
								nA
I_{CMP}	CMP peripheral adder measured by placing the device in VLLS1 mode with CMP enabled using the 6-bit DAC and a single external input for compare. Includes 6-bit DAC power consumption.	22	22	22	22	22	22	μA
I_{UART}	UART peripheral adder measured by placing the device in STOP or VLPS mode with selected clock source waiting for RX data at 115200 baud rate. Includes selected clock source power consumption. <ul style="list-style-type: none"> • IRC8M (8 MHz internal reference clock) • IRC2M (2 MHz internal reference clock) 	114 34	114 34	114 34	114 34	114 34	114 34	μA
I_{TPM}	TPM peripheral adder measured by placing the device in STOP or VLPS mode with selected clock source configured for output compare generating 100 Hz clock signal. No load is placed on the I/O generating the clock signal. Includes selected clock source and I/O switching currents. <ul style="list-style-type: none"> • IRC8M (8 MHz internal reference clock) • IRC2M (2 MHz internal reference clock) 	147 42	147 42	147 42	147 42	147 42	147 42	μA
I_{BG}	Bandgap adder when BGEN bit is set and device is placed in VLPx or VLLSx mode.	45	45	45	45	45	45	μA
I_{ADC}	ADC peripheral adder combining the measured values at V_{DD} and V_{DDA} by placing the device in STOP or VLPS mode. ADC is configured for low power mode using the internal clock and continuous conversions.	330	330	330	330	330	330	μA
I_{LCD}	LCD peripheral adder measured by placing the device in VLLS1 mode with external 32 kHz crystal enabled by means of the OSC0_CR[EREFSTEN, EREFSTEN] bits. VIREG disabled, resistor bias network enabled, 1/8 duty cycle, 8 x 36 configuration for driving 288 Segments, 32 Hz frame rate, no LCD glass connected. Includes ERCLK32K (32 kHz external crystal) power consumption.	4.5	4.5	4.5	4.5	4.5	4.5	μA

2.2.5.1 Diagram: Typical IDD_RUN operating behavior

The following data was measured under these conditions:

- MCG-Lite in HIRC for run mode, and LIRC for VLPR mode
- USB regulator disabled
- No GPIOs toggled
- Code execution from flash
- For the ALLOFF curve, all peripheral clocks are disabled except FTFA

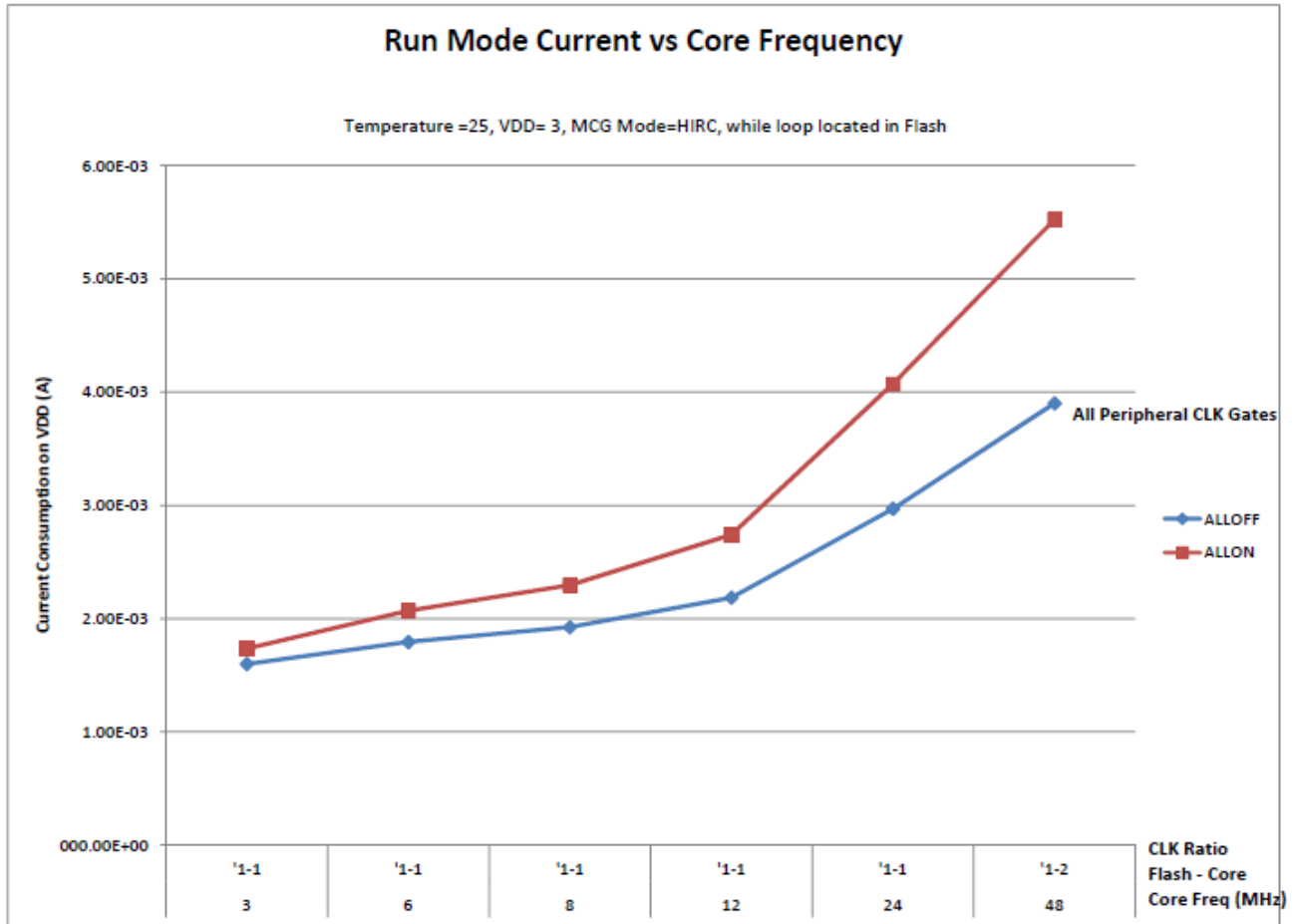
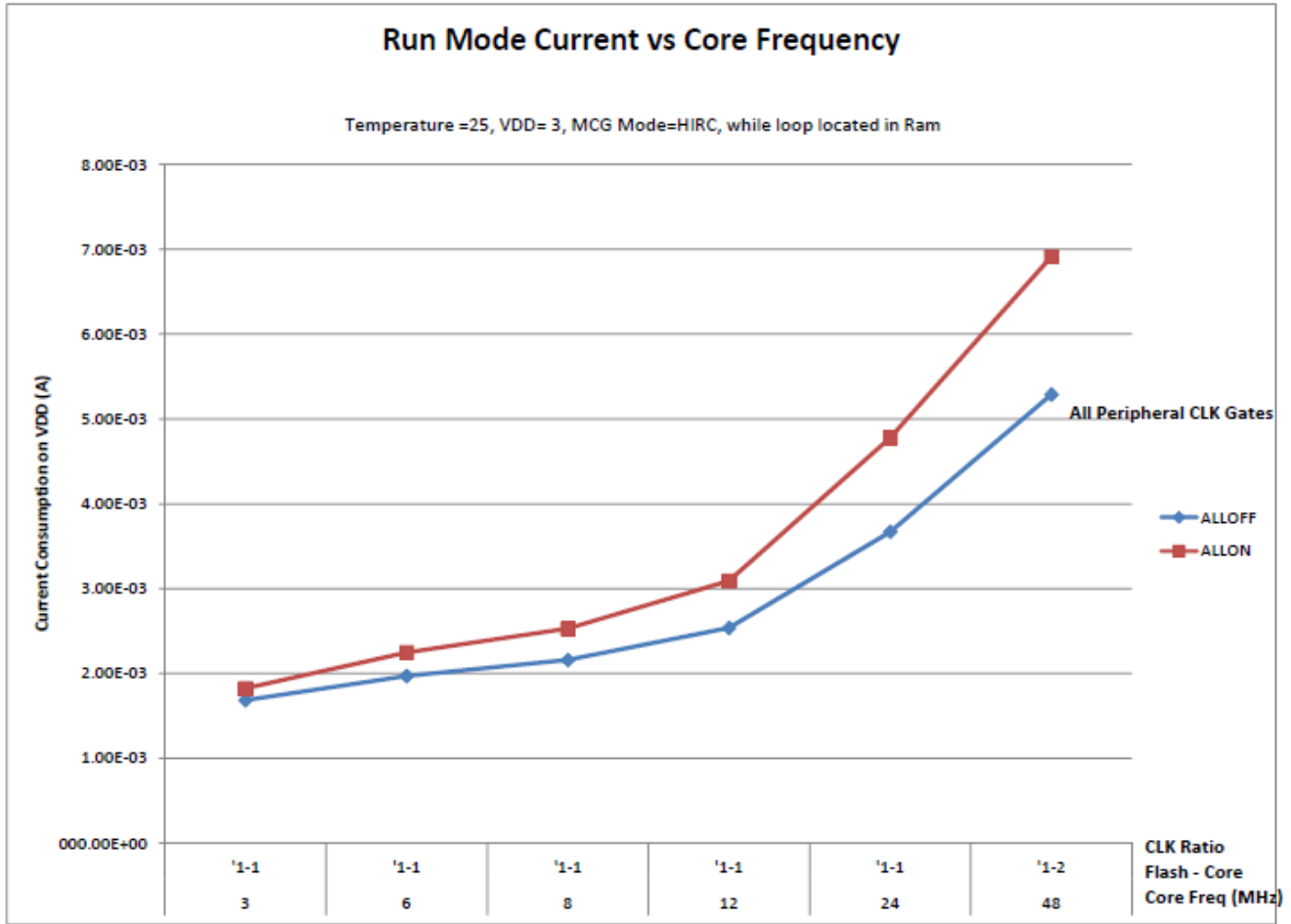

Figure 2. Run mode supply current vs. core frequency



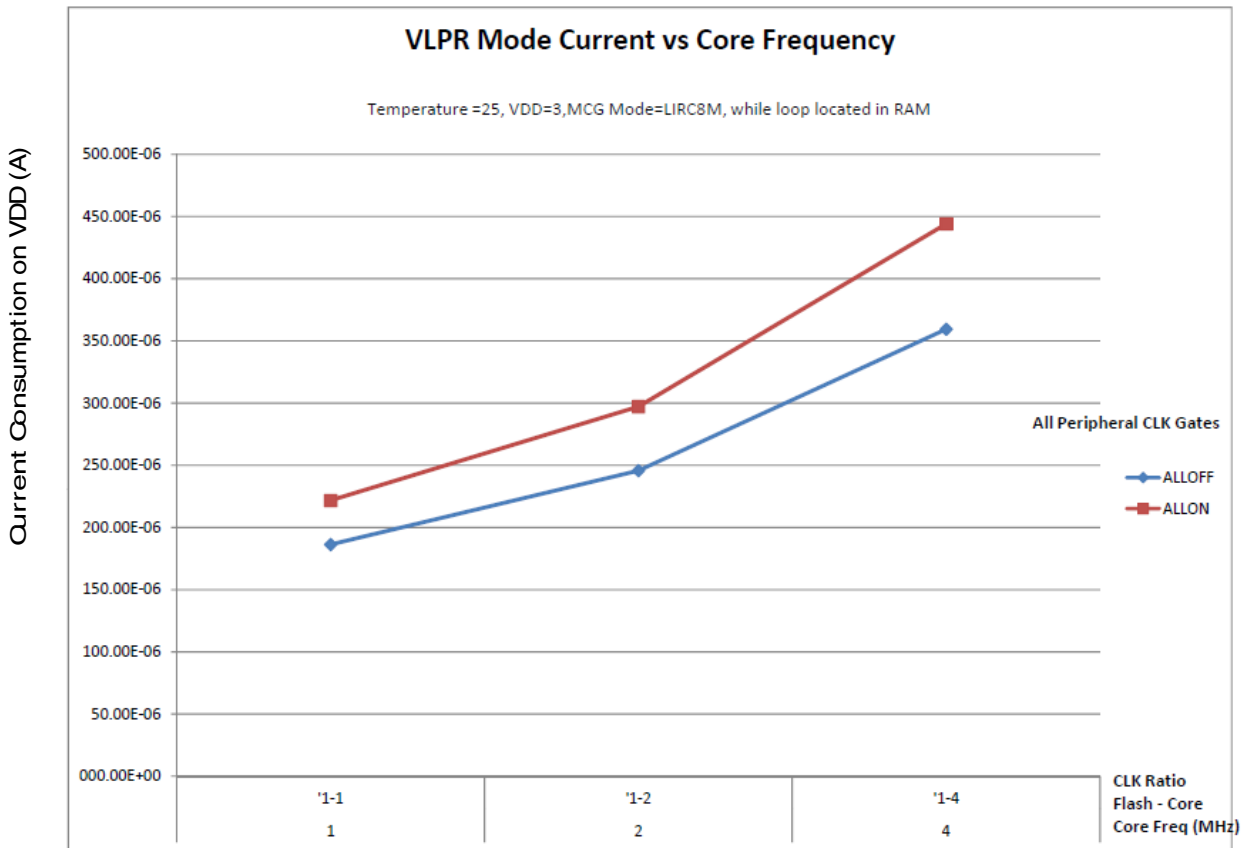

Figure 3. VLPR mode current vs. core frequency

2.2.6 EMC radiated emissions operating behaviors

Table 11. EMC radiated emissions operating behaviors for 64-pin LQFP package

Symbol	Description	Frequency band (MHz)	Typ.	Unit	Notes
V _{RE1}	Radiated emissions voltage, band 1	0.15–50	11	dBμV	1, 2
V _{RE2}	Radiated emissions voltage, band 2	50–150	12	dBμV	
V _{RE3}	Radiated emissions voltage, band 3	150–500	10	dBμV	
V _{RE4}	Radiated emissions voltage, band 4	500–1000	6	dBμV	
V _{RE_IEC}	IEC level	0.15–1000	N	—	2, 3

1. Determined according to IEC Standard 61967-1, *Integrated Circuits - Measurement of Electromagnetic Emissions, 150 kHz to 1 GHz Part 1: General Conditions and Definitions* and IEC Standard 61967-2, *Integrated Circuits - Measurement of Electromagnetic Emissions, 150 kHz to 1 GHz Part 2: Measurement of Radiated Emissions—TEM*

General

Cell and Wideband TEM Cell Method. Measurements were made while the microcontroller was running basic application code. The reported emission level is the value of the maximum measured emission, rounded up to the next whole number, from among the measured orientations in each frequency range.

2. $V_{DD} = 3.3\text{ V}$, $T_A = 25\text{ }^\circ\text{C}$, $f_{OSC} = \text{IRC48M}$, $f_{SYS} = 48\text{ MHz}$, $f_{BUS} = 24\text{ MHz}$
3. Specified according to Annex D of IEC Standard 61967-2, *Measurement of Radiated Emissions—TEM Cell and Wideband TEM Cell Method*

2.2.7 Designing with radiated emissions in mind

To find application notes that provide guidance on designing your system to minimize interference from radiated emissions:

1. Go to www.freescale.com.
2. Perform a keyword search for “EMC design.”

2.2.8 Capacitance attributes

Table 12. Capacitance attributes

Symbol	Description	Min.	Max.	Unit
C_{IN}	Input capacitance	—	7	pF

2.3 Switching specifications

2.3.1 Device clock specifications

Table 13. Device clock specifications

Symbol	Description	Min.	Max.	Unit
Normal run mode				
f_{SYS}	System and core clock ¹	—	48	MHz
f_{BUS}	Bus clock ¹	—	24	MHz
f_{FLASH}	Flash clock ¹	—	24	MHz
f_{SYS_USB}	System and core clock when Full Speed USB in operation	20	—	MHz
f_{LPTMR}	LPTMR clock	—	24	MHz
VLPR and VLPS modes ²				
f_{SYS}	System and core clock	—	4	MHz
f_{BUS}	Bus clock	—	1	MHz
f_{FLASH}	Flash clock	—	1	MHz
f_{LPTMR}	LPTMR clock ³	—	24	MHz

Table continues on the next page...

Table 13. Device clock specifications (continued)

Symbol	Description	Min.	Max.	Unit
f _{LPTMR_ERCLK}	LPTMR external reference clock	—	16	MHz
f _{osc_hi_2}	Oscillator crystal or resonator frequency — high frequency mode (high range) (MCG_C2[RANGE]=1x)	—	16	MHz
f _{TPM}	TPM asynchronous clock	—	8	MHz
f _{LPUART0/1}	LPUART0/1 asynchronous clock	—	8	MHz

1. The maximum value of system clock, core clock, bus clock, and flash clock under normal run mode can be 3% higher than the specified maximum frequency when IRC 48MHz is used as the clock source.
2. The frequency limitations in VLPR and VLPS modes here override any frequency specification listed in the timing specification for any other module. These same frequency limits apply to VLPS, whether VLPS was entered from RUN or from VLPR.
3. The LPTMR can be clocked at this speed in VLPR or VLPS only when the source is an external pin.

2.3.2 General switching specifications

These general-purpose specifications apply to all signals configured for GPIO and UART signals.

Table 14. General switching specifications

Description	Min.	Max.	Unit	Notes
GPIO pin interrupt pulse width (digital glitch filter disabled) — Synchronous path	1.5	—	Bus clock cycles	1
External RESET and NMI pin interrupt pulse width — Asynchronous path	100	—	ns	2
GPIO pin interrupt pulse width — Asynchronous path	16	—	ns	2
Port rise and fall time	—	36	ns	3

1. The synchronous and asynchronous timing must be met.
2. This is the shortest pulse that is guaranteed to be recognized.
3. 75 pF load

2.4 Thermal specifications

2.4.1 Thermal operating requirements

Table 15. Thermal operating requirements

Symbol	Description	Min.	Max.	Unit	Notes
T _J	Die junction temperature	−40	125	°C	
T _A	Ambient temperature	−40	105	°C	1

Peripheral operating requirements and behaviors

- Maximum T_A can be exceeded only if the user ensures that T_J does not exceed the maximum. The simplest method to determine T_J is: $T_J = T_A + R_{\theta JA} \times \text{chip power dissipation}$.

2.4.2 Thermal attributes

Table 16. Thermal attributes

Board type	Symbol	Description	64 LQFP	64 MAPBGA	Unit	Notes
Single-layer (1S)	$R_{\theta JA}$	Thermal resistance, junction to ambient (natural convection)	70	50.3	°C/W	1
Four-layer (2s2p)	$R_{\theta JA}$	Thermal resistance, junction to ambient (natural convection)	51	42.9	°C/W	
Single-layer (1S)	$R_{\theta JMA}$	Thermal resistance, junction to ambient (200 ft./min. air speed)	58	41.4	°C/W	
Four-layer (2s2p)	$R_{\theta JMA}$	Thermal resistance, junction to ambient (200 ft./min. air speed)	45	38.0	°C/W	
—	$R_{\theta JB}$	Thermal resistance, junction to board	33	39.6	°C/W	2
—	$R_{\theta JC}$	Thermal resistance, junction to case	20	27.3	°C/W	3
—	Ψ_{JT}	Thermal characterization parameter, junction to package top outside center (natural convection)	4	0.4	°C/W	4
—	Ψ_{JB}	Thermal characterization parameter, junction to package bottom (natural convection)	-	12.6	°C/W	5

- Determined according to JEDEC Standard JESD51-2, *Integrated Circuits Thermal Test Method Environmental Conditions—Natural Convection (Still Air)*, or EIA/JEDEC Standard JESD51-6, *Integrated Circuit Thermal Test Method Environmental Conditions—Forced Convection (Moving Air)*.
- Determined according to JEDEC Standard JESD51-8, *Integrated Circuit Thermal Test Method Environmental Conditions—Junction-to-Board*.
- Determined according to Method 1012.1 of MIL-STD 883, *Test Method Standard, Microcircuits*, with the cold plate temperature used for the case temperature. The value includes the thermal resistance of the interface material between the top of the package and the cold plate.
- Determined according to JEDEC Standard JESD51-2, *Integrated Circuits Thermal Test Method Environmental Conditions—Natural Convection (Still Air)*.
- Thermal characterization parameter indicating the temperature difference between package bottom center and the junction temperature per JEDEC JESD51-12. When Greek letters are not available, the thermal characterization parameter is written as Psi-JB.

3 Peripheral operating requirements and behaviors

3.1 Core modules

3.1.1 SWD electricals

Table 17. SWD full voltage range electricals

Symbol	Description	Min.	Max.	Unit
	Operating voltage	1.71	3.6	V
J1	SWD_CLK frequency of operation <ul style="list-style-type: none"> Serial wire debug 	0	25	MHz
J2	SWD_CLK cycle period	1/J1	—	ns
J3	SWD_CLK clock pulse width <ul style="list-style-type: none"> Serial wire debug 	20	—	ns
J4	SWD_CLK rise and fall times	—	3	ns
J9	SWD_DIO input data setup time to SWD_CLK rise	10	—	ns
J10	SWD_DIO input data hold time after SWD_CLK rise	0	—	ns
J11	SWD_CLK high to SWD_DIO data valid	—	32	ns
J12	SWD_CLK high to SWD_DIO high-Z	5	—	ns

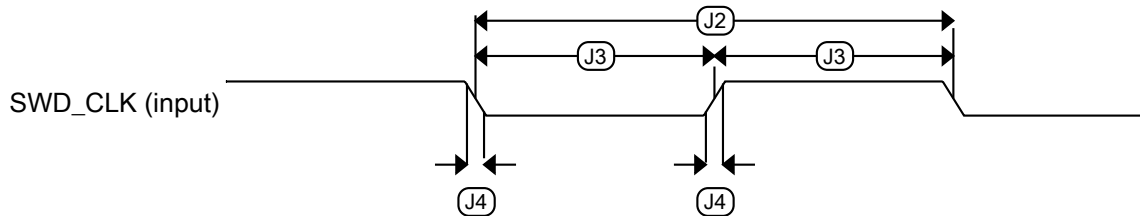

Figure 4. Serial wire clock input timing

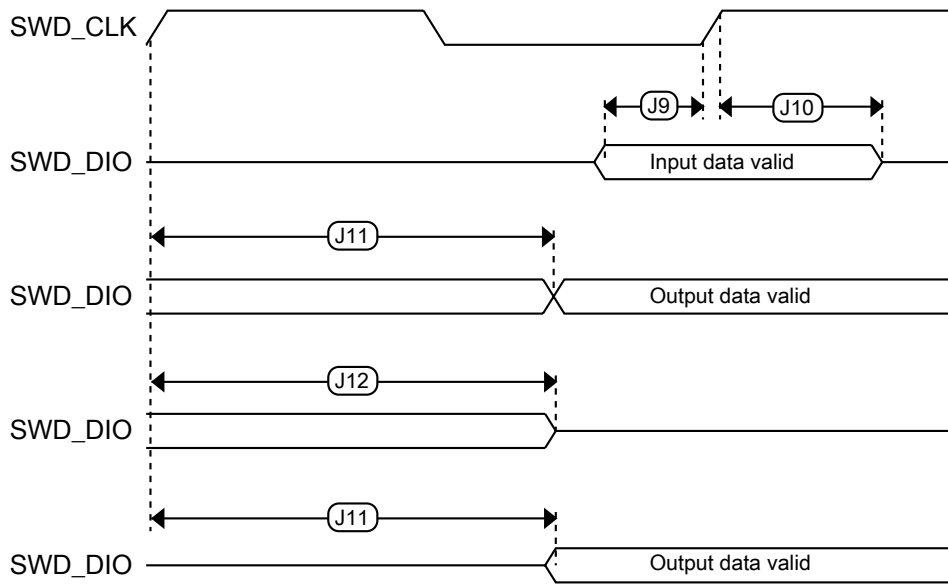

Figure 5. Serial wire data timing

3.2 System modules

There are no specifications necessary for the device's system modules.

3.3 Clock modules

3.3.1 MCG-Lite specifications

Table 18. IRC48M specification

Symbol	Description	Min.	Typ.	Max.	Unit	Notes
I_{DD}	Supply current	—	400	500	μA	—
f_{IRC}	Output frequency	—	48	—	MHz	—
$\Delta f_{irc48m_ol_lv}$	Open loop total deviation of IRC48M frequency at low voltage (VDD=1.71V-1.89V) over temperature	—	± 0.5	± 1.5	$\%f_{irc48m}$	1
$\Delta f_{irc48m_ol_hv}$	Open loop total deviation of IRC48M frequency at high voltage (VDD=1.89V-3.6V) over temperature	—	± 0.5	± 1.0	$\%f_{irc48m}$	1

Table continues on the next page...

Table 18. IRC48M specification (continued)

Symbol	Description	Min.	Typ.	Max.	Unit	Notes
T_j	Period jitter (RMS)	—	35	150	ps	—
T_{su}	Startup time	—	2	3	μ s	—

1. The maximum value represents characterized results equivalent to mean plus or minus three times the standard deviation (mean $\pm 3\sigma$).

Table 19. IRC8M/2M specification

Symbol	Description	Min.	Typ.	Max.	Unit	Notes
I_{DD_2M}	Supply current in 2 MHz mode	—	14	17	μ A	—
I_{DD_8M}	Supply current in 8 MHz mode	—	30	35	μ A	—
f_{IRC_2M}	Output frequency	—	2	—	MHz	—
f_{IRC_8M}	Output frequency	—	8	—	MHz	—
$f_{IRC_T_2M}$	Output frequency range (trimmed)	—	—	± 3	$\%f_{IRC}$	—
$f_{IRC_T_8M}$	Output frequency range (trimmed)	—	—	± 3	$\%f_{IRC}$	—
T_{su_2M}	Startup time	—	—	12.5	μ s	—
T_{su_8M}	Startup time	—	—	12.5	μ s	—