



Chipsmall Limited consists of a professional team with an average of over 10 year of expertise in the distribution of electronic components. Based in Hongkong, we have already established firm and mutual-benefit business relationships with customers from,Europe,America and south Asia,supplying obsolete and hard-to-find components to meet their specific needs.

With the principle of “Quality Parts,Customers Priority,Honest Operation,and Considerate Service”,our business mainly focus on the distribution of electronic components. Line cards we deal with include Microchip,ALPS,ROHM,Xilinx,Pulse,ON,Everlight and Freescale. Main products comprise IC,Modules,Potentiometer,IC Socket,Relay,Connector.Our parts cover such applications as commercial,industrial, and automotives areas.

We are looking forward to setting up business relationship with you and hope to provide you with the best service and solution. Let us make a better world for our industry!



Contact us

Tel: +86-755-8981 8866 Fax: +86-755-8427 6832

Email & Skype: info@chipsmall.com Web: www.chipsmall.com

Address: A1208, Overseas Decoration Building, #122 Zhenhua RD., Futian, Shenzhen, China



Cell Type ML614 Specifications

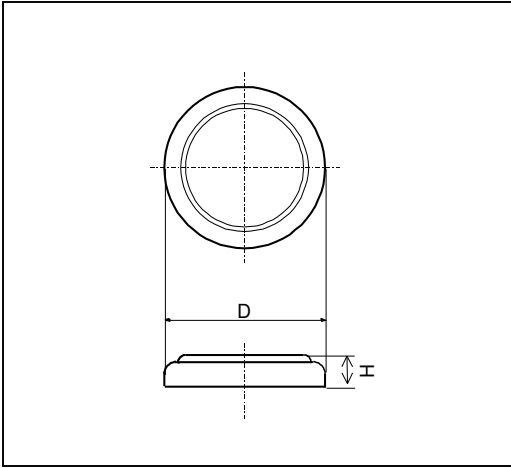

| | | |
|--|--------------------------|------------|
| Nominal Voltage (V) | | 3 |
| Nominal Capacity (mAh) ^{*1} | | 3.4 |
| Standard Charge/Discharge Current (mA) | | 0.015 |
| Max. Discharge Current (mA) | Pulse ^{*2} | 1.5 |
| Charge/Discharge Cycle Characteristics | Discharging Depth of 20% | 300 |
| Charging Method (V) | Constant Voltage Charge | 2.8 ~ 3.25 |
| Operating Temperature Range (°C) | | -20 ~ +60 |
| Dimensions (mm) | Diameter(D) | 6.8 |
| | Height(H) | 1.4 |
| Approx. Weight (g) | | 0.16 |

- * Expected life is 5 years at room temperature.
- * Consult with FDK when considering multiple-cell construction.
- *¹ Nominal capacity is determined at an end voltage of 2.0V when the battery is allowed to discharge at a standard current level at +23°C.
- *² Current value for obtaining 2.0V cell voltage when pulse is applied for 15 seconds at 50% discharge depth (50% of the nominal capacity) at +23°C.

Note) Battery Handling Precautions

English) http://www.fdk.com/battery/lithium_e/handling_precaution.html
 Japanese) http://www.fdk.co.jp/battery/lithium/handling_precaution.html

Typical Characteristics

Charge Characteristics

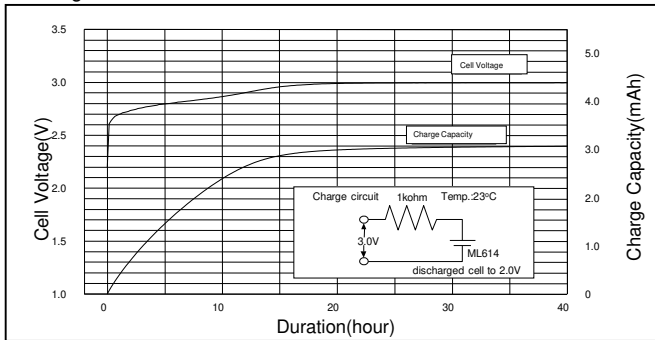

Temperature Discharge Characteristics

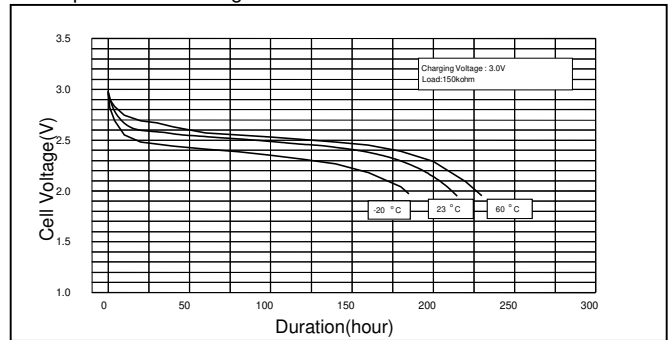

Discharge Characteristics after Storage

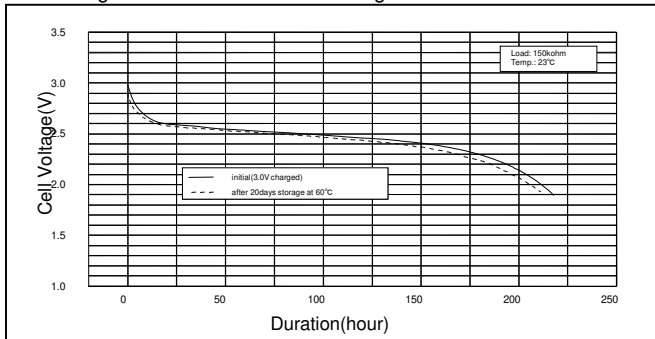

Discharge Characteristics after Continuous Charge

