



Chipsmall Limited consists of a professional team with an average of over 10 year of expertise in the distribution of electronic components. Based in Hongkong, we have already established firm and mutual-benefit business relationships with customers from,Europe,America and south Asia,supplying obsolete and hard-to-find components to meet their specific needs.

With the principle of “Quality Parts,Customers Priority,Honest Operation,and Considerate Service”,our business mainly focus on the distribution of electronic components. Line cards we deal with include Microchip,ALPS,ROHM,Xilinx,Pulse,ON,Everlight and Freescale. Main products comprise IC,Modules,Potentiometer,IC Socket,Relay,Connector.Our parts cover such applications as commercial,industrial, and automotives areas.

We are looking forward to setting up business relationship with you and hope to provide you with the best service and solution. Let us make a better world for our industry!



Contact us

Tel: +86-755-8981 8866 Fax: +86-755-8427 6832

Email & Skype: info@chipsmall.com Web: www.chipsmall.com

Address: A1208, Overseas Decoration Building, #122 Zhenhua RD., Futian, Shenzhen, China



THIS DRAWING IS UNPUBLISHED. RELEASED FOR PUBLICATION
 © COPYRIGHT - By - ALL RIGHTS RESERVED.

LOC		DIST		REVISIONS			
P	LTR	DESCRIPTION		DATE	DWN	APVD	
AD	00	A1	REVISED PER ECO-11-004917	11MAR11	RK	HMR	

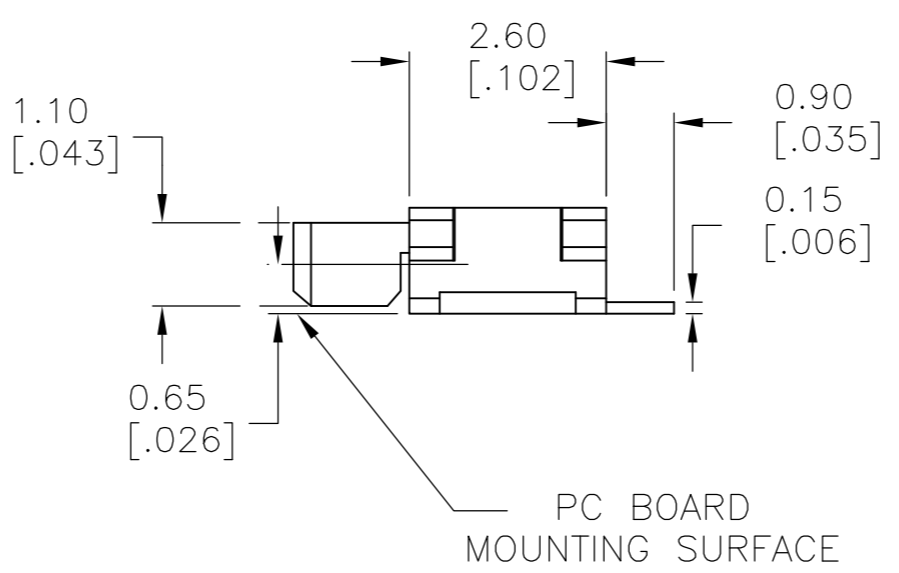
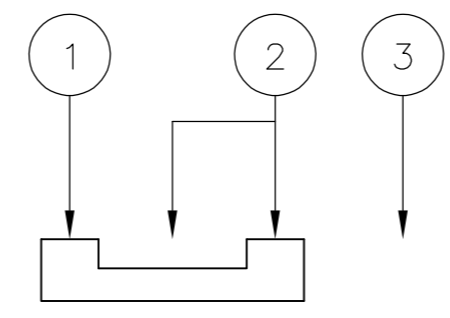
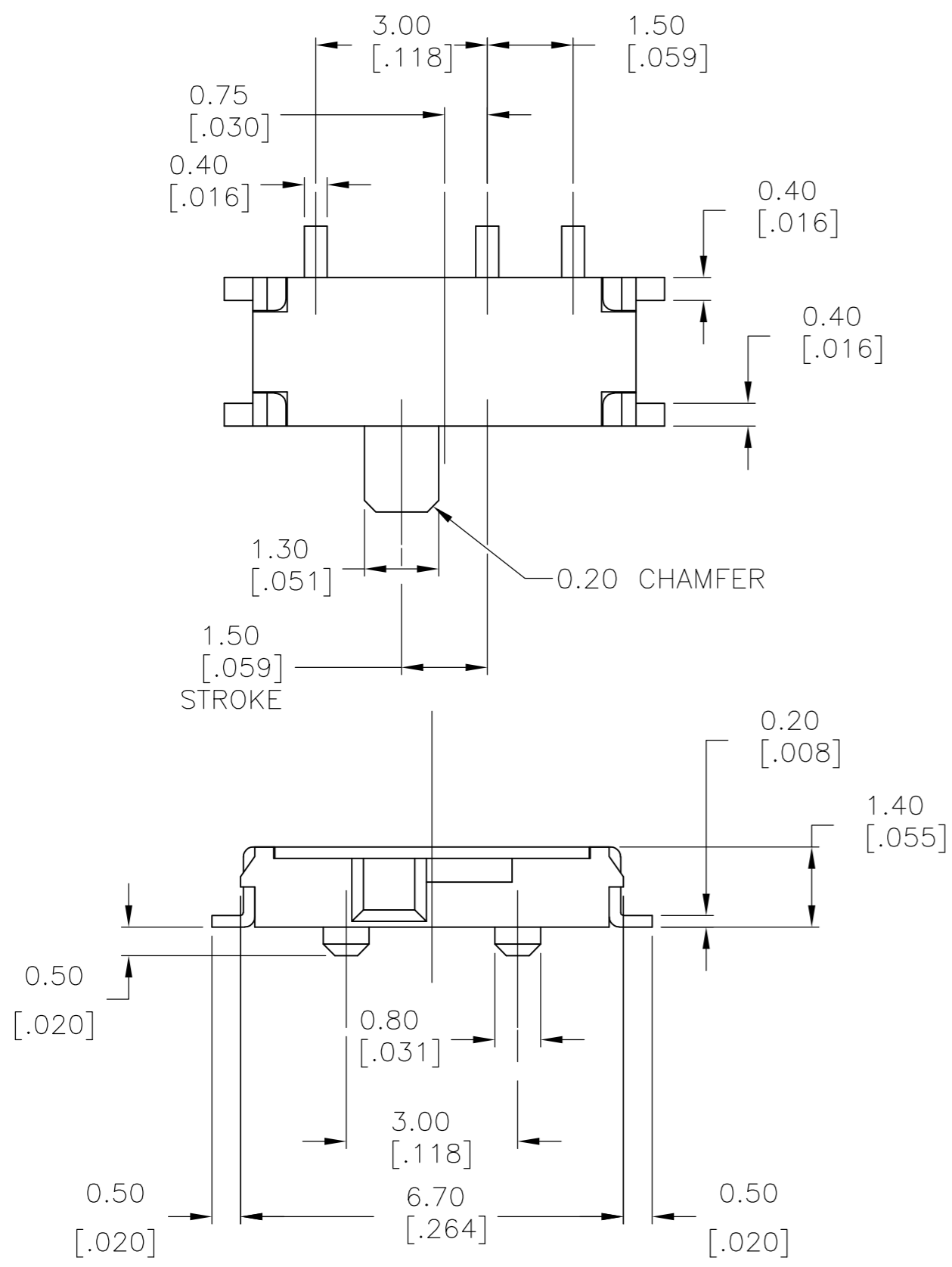

SPECIFICATIONS:

MATERIALS:

CASE: LCP UL94V-0, BLACK
 COVER, NICKEL SILVER ALLOY-PLATE SILVER OVER NICKEL.
 ACTUATOR: NYLON 46 UL94V-0, BLACK
 MOVING CONTACT: COPPER ALLOY-PLATE SILVER OVER NICKEL
 FIXED CONTACT/TERMINAL, COPPER ALLOY-PLATE SILVER OVER NICKEL
 SPRING PLATE, STAINLESS STEEL-PLATE SILVER OVER NICKEL

ELECTRICAL:

CONTACT RATING: 300mA@4VDC.
 INITIAL CONTACT RESISTANCE, 70 MILLIOHMS MAX.
 FINAL CONTACT RESISTANCE, 100 MILLIOHMS MAX.
 INSULATION RESISTANCE: 100 MEGAOHMS MIN.
 DIELECTRIC STRENGTH: 100 VAC FOR 1 MINUTE.
 LIFE EXPECTANCY: 10,000 CYCLES.

MECHANICAL:

ACTUATION FORCE: 200±100g.
 ACTUATION TRAVEL, 1.50±0.15
 LIFE EXPECTANCY, 10,000 CYCLES.

ENVIRONMENTAL:

OPERATING TEMPERATURE, -20 TO +85 DEGREES C
 STORAGE TEMPERATURE, -40 TO +100 DEGREES C
 HUMIDITY, MIL-STD-202, METHOD 103, CONDITION B
 MOISTURE RESISTANCE, MIL-STD-202, METHOD 106
 THERMAL SHOCK, MIL-STD-202, METHOD 107, CONDITION A
 SOLDERABILITY, PER EIA-364-52, CLASS 2, CATEGORY 1,
 95%MINIMUM COVERAGE
 RESISTENCE TO SOLDER HEAT, 109-201, CONDITION B

NOTES:

- ALL MATERIALS AND FINISHES SHALL COMPLY WITH EU DIRECTIVE 2002/95/EC OF 27JAN2003(ROHS).
- TAPE AND REEL PACKAGING PER EIA-481, TAPE WIDTH 16mm, PITCH 8mm AND 3300 pcs PER REEL.

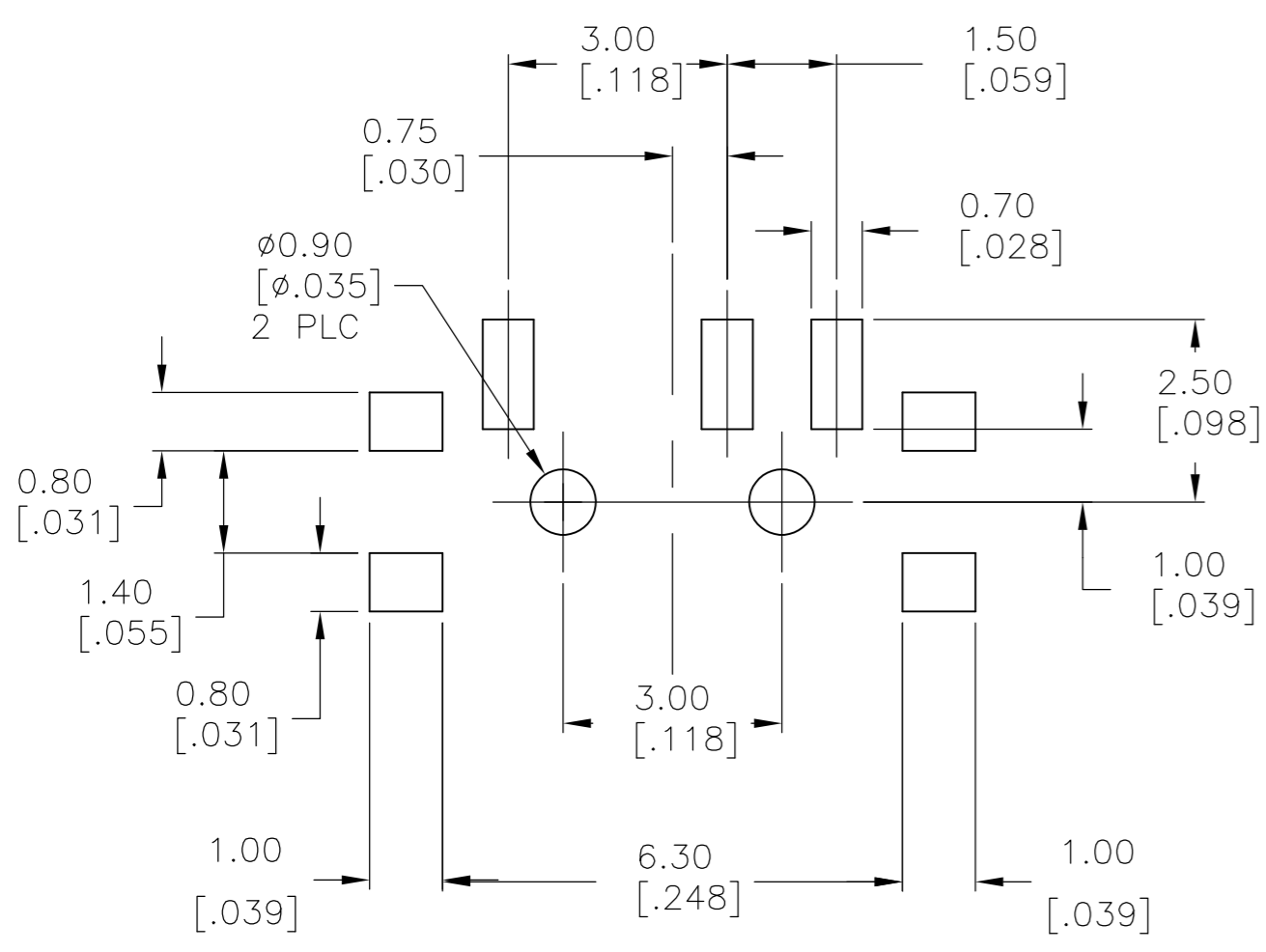

8MM	16MM	3,300	T&R	MLL1200STR	1437575-2
N/A	N/A	N/A	BULK	MLL1200S	1437575-1
Pitch	Tape Width	QTY per Reel	PKG	ALCO P/N	PART NO.

DIMENSIONS:		TOLERANCES UNLESS OTHERWISE SPECIFIED:		DWN		R BROWN		04DEC01	
mm [INCHES]		0 PLC	± -	CHK	H WYNKOOP	04DEC01	TE Connectivity SLIDE SWITCH SPDT,R/A LOW PROFILE SMT		
		1 PLC	± -	APVD	H WYNKOOP	04DEC01			
		2 PLC	± 0.13[.005]	PRODUCT SPEC					
		3 PLC	± -	APPLICATION SPEC					
		4 PLC	± -	MATERIAL		WEIGHT	A2 00779		SCALE
		ANGLES	± -	FINISH		FINISH	C=1437575-1		SHEET
							CUSTOMER DRAWING		10:1
									SHEET
									1 of 1
									REV
									A1