



Chipsmall Limited consists of a professional team with an average of over 10 year of expertise in the distribution of electronic components. Based in Hongkong, we have already established firm and mutual-benefit business relationships with customers from,Europe,America and south Asia,supplying obsolete and hard-to-find components to meet their specific needs.

With the principle of "Quality Parts,Customers Priority,Honest Operation,and Considerate Service",our business mainly focus on the distribution of electronic components. Line cards we deal with include Microchip,ALPS,ROHM,Xilinx,Pulse,ON,Everlight and Freescale. Main products comprise IC,Modules,Potentiometer,IC Socket,Relay,Connector.Our parts cover such applications as commercial,industrial, and automotives areas.

We are looking forward to setting up business relationship with you and hope to provide you with the best service and solution. Let us make a better world for our industry!



Contact us

Tel: +86-755-8981 8866 Fax: +86-755-8427 6832

Email & Skype: info@chipsmall.com Web: www.chipsmall.com

Address: A1208, Overseas Decoration Building, #122 Zhenhua RD., Futian, Shenzhen, China



Features and Benefits

- 2 High power independent drivers (2.5Apeak in square and 1Apeak in sine mode)
- Full bridge drive capabilities
- Built-in protection features (antenna fault detection, over current and T°) for guaranteed safe operation in all conditions
- Easy-to-use through SPI interface
- Built-in ASK and FSK immobilizers

Application Examples

- Passive Start system
- TPMS Initiator
- LF door opener
- Active RFID initiator

Ordering Information

Part Code	Temperature Code	Package Code	Option Code	Packing Form Code
MLX74190	R (-40°C to 105°C)	PF (Lead free TQFP 7x7 48 leads)	ABA-000	RE

This document is a Product Preview, to get access to the full datasheet and related documentations, please directly contact Melexis at sales_europe@melexis.com or sales_usa@melexis.com.

Description

The MLX74190 low-frequency (LF) initiator IC consists in two high power LF drivers and built-in immobilizers (IMMO).

The main application for the MLX74190 is automotive remote passive start, where the IC transmits a high power LF telegram to wake-up the key inside the car. The key sends out its identification number to the car via an ultra-high frequency (UHF) signal, enabling the engine to start. The MLX74190 also features two built-in Immobilizers (for ASK and FSK communications), used when the battery of the key is depleted. In this case, the key is placed in a specific zone close to the initiator and a full passive RFID communication is initiated. The load modulation signal returns by the key is received and demodulated by the MLX74190.



Figure 1: Passive Start Application

The MLX74190 can also serve for a similar purpose with other vehicles such as; motorcycles, scooters, all-terrain vehicle (ATV), jet skis, snowmobiles and motorboats, where the key holder can be detected when approaching the engine and will be able to activate it from a “Start” button, or as a ‘dead man switch’ so that if the driver falls off then the engine is automatically cut. In addition it may be incorporated into building access systems, tire pressure monitoring system (TPMS) initiators and pet identification system. Both LF drivers are independently programmable to generate sine (max. 1Ap) or square (max. 2.5Ap) waves, with a frequency from 109kHz to 140kHz and an output amplitude from 0.25 to 32Vpp. The two drivers can be used in full or half bridge configuration and are protected against overload (over-current and over-temperature). A built-in diagnosis function allows detecting any wrong connection with the LF antenna (Short to GND, Short to Vbat, open load or wrong resonance frequency).

The MLX74190 is supplied by an external VS voltage from 6-40V and VDD voltage of typically 5V. The VS voltage can be generated by an external DC-DC converter or by DC voltage from vehicle supply.

The MLX74190 is controlled through a standard SPI interface (SDI, SDO, SCK and NCS) and an interrupt pin is generated on-purpose by the IC. The MLX74190 is clocked either with a 2 MHz clock frequency signal coming from the MCU or by an on-chip oscillator connected to an external 4 MHz crystal or ceramic resonator.

Table of Contents

1 Absolute Maximum Ratings.....	3
2 Range of Functionality.....	3
1 Pin out description.....	4
2 High Level Block Diagram.....	6
3 Operating Modes.....	7
3.1 Sleep Mode.....	7
3.2 Standby Mode.....	7
3.3 Transmission Mode.....	7
3.4 Diagnosis Mode.....	7
4 Device Description.....	8
4.1 Power supplies, internal regulation and references.....	8
4.2 System clock.....	8
4.3 Low Frequency Generation.....	8
4.4 Sine wave generation.....	8
4.5 Square wave generation.....	8
4.6 Modulator.....	8
4.7 Immobilizer ASK.....	8
4.8 Immobilizer FSK.....	9
4.9 Digital SPI Interface.....	9
4.10 SPI Commands.....	9
4.11 Failure Flags.....	9
4.12 Antenna diagnosis.....	9
4.13 Current Measurement.....	9
5 Application Information.....	10
1 Package and marking information.....	11
1.1 Package data TQFP eP 48L (7x7, 48 leads).....	11
1.2 Marking instruction.....	12
2 Standard information regarding manufacturability of Melexis products with different soldering processes ..	13
3 Disclaimer.....	14
4 Contact Information.....	14

1 Absolute Maximum Ratings

Parameter	Symbol	Min	Max	Units	Comment
Driver Supply Voltage	VS		45	V	
5V Supply	VDD		7	V	
Storage Temperature Range	T _s	-55	150	°C	
Junction Temperature	T _j	-40	165	°C	
Static thermal resistance from Junction to Ambient	R _{thja}		28	K/W	
ESD Sensitivity (HBM global pins)	V _{ESDglobal}	+/-3		kV	OUT1, OUT2, VS, ASK_RXi, FSK_RXi
ESD Sensitivity (HBM local pins)	V _{ESDlocal}	+/-2		kV	All other pins
ESD Sensitivity (CDM)	V _{CDM_sens} (HBM Global pins)	+/-500		V	

Table 1: Absolute maximum ratings

Exceeding the absolute maximum ratings may cause permanent damage. Exposure to absolute-maximum-rated conditions for extended periods may affect device reliability.

2 Range of Functionality

Parameter	Symbol	Min Value	Typical	Max Value	Units
5V Supply	VDD	4.5	5	5.5	V
Driver Supply Voltage – operating	VS	6	-	40	V
Input voltage range on pins: NCS, SCLK, SDI, WUP, CLK_IN and REMOTE_DATA_IN, OSC	V _{in_dig}	-0.5	VDD	5.5	V
Operating Temperature Range	T _A	-40	-	105	°C

Table 2: Range of functionality

Note:

Every electrical parameter specified in this document, except if specifically indicated, is valid in the complete temperature range: -40 / 105°C.

1 Pin out description

Pin №	Name	Type	Function
1	FSK_RX2	Analog	FSK Immobilizer input pin 2
2	FSK_FB2	Analog	FSK Immobilizer feedback loop 2
3	IP_SENSE	Analog	Current Measurement Output Voltage
4	RBIAS	Analog	Reference Resistor connection for trimming the current reference
5	EXT_CLK	Digital	External clock used in combination with CLK_IN to connect an external resonator
6	CLK_IN	Digital	Input clock coming from MCU or connected to external resonator
7	OSC	Analog	125KHz clock input/output
8	OUT1	Analog	Antenna connection (driver output 1)
9	GND	Ground	Power ground for driver outputs
10	VS	Supply	Supply for driver outputs
11	OUT2	Analog	Antenna connection (driver output 2)
12	CLK_OUT	Digital	2MHz clock output
13	WUP	Digital	Wake up pin
15	SCLK	Digital	Serial clock for SPI
16	NCS	Digital	Not chip select for SPI
17	SDO	Digital	Slave data output for SPI
18	SDI	Digital	Slave data input for SPI
19	IRQ	Digital	Interrupt signal output
20	D_OUT	Digital	Immobilizer data / Digital modulation output signal
21	RDI	Digital	Input signal for direct LF modulation (RDI = Remote_Data_In)
22	VDDA_CAP	Supply	Analog internal regulator decoupling cap.
23	ASK_RX1	Analog	ASK Immobilizer input 1
24	ASK_RX2	Analog	ASK Immobilizer input 2
25	AGND	Ground	Analog ground
36	VDD	Supply	5V supply
38	DGND	Ground	Digital ground
41	VDDD_CAP	Supply	Digital internal regulator decoupling capacitor
47	FSK_RX1	Analog	FSK Immobilizer input pin 1
48	FSK_FB1	Analog	FSK Immobilizer feedback loop 1
14, 46	Reserved	NA	Must be externally connected to ground
26,27,28,29,30, 31,32, 33, 34, 35, 37,39, 40, 42, 43, 44, 45	NC	NA	Not connected
EXP	EXP	Ground	Exposed PAD, to be connected to ground

Table 3: Pin out description

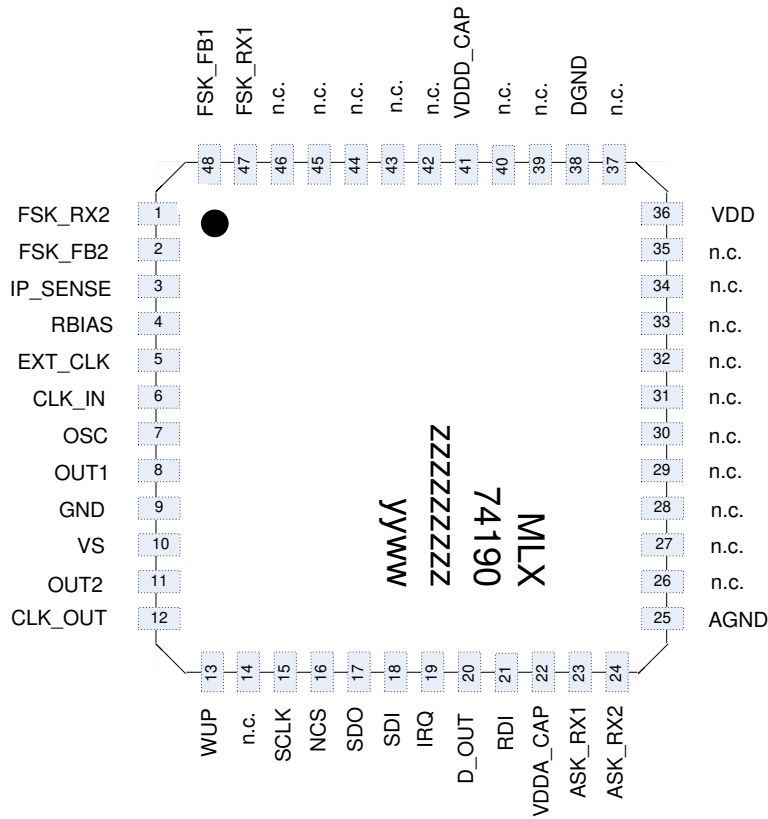

Table 4: Top view of the package TQFP48

2 High Level Block Diagram

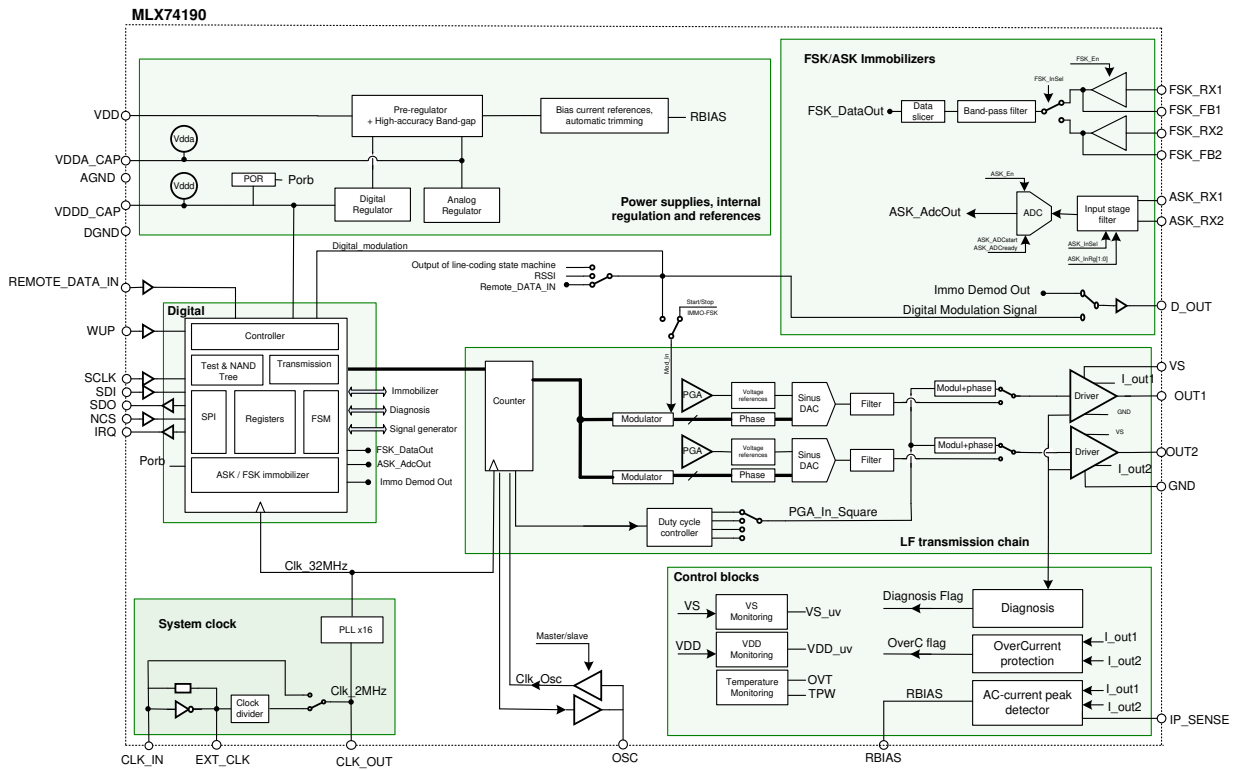

Figure 2: MLX74190 high level block diagram

3 Operating Modes

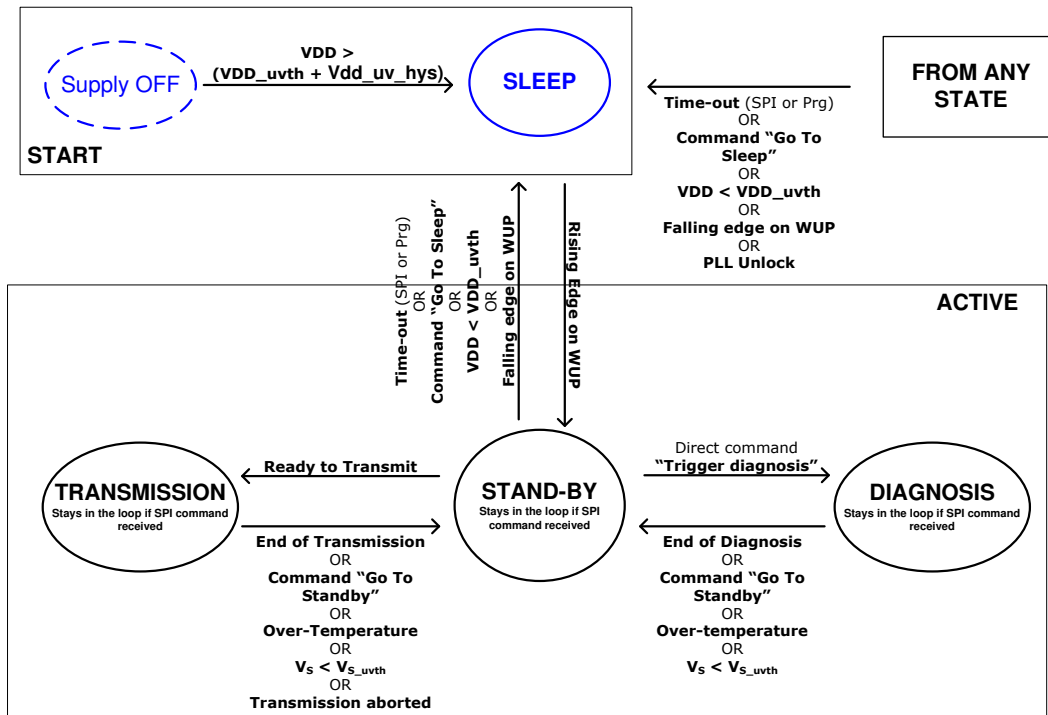

Figure 3: MLX74190 operating modes transition diagram

3.1 Sleep Mode

In SLEEP mode, all internal registers are set to their default values, flags and pointer are reset. All antenna outputs are switched to Hi-Z mode, the PLL is switched OFF and the SPI interface is deactivated. The device exits SLEEP mode when a rising edge is applied on the pin WUP by the external host MCU.

3.2 Standby Mode

In STANDBY mode, all antenna outputs are switched to Hi-Z mode, all digital outputs are switched to their default values and the internal LF transmission chain is deactivated. The SPI interface is activated and the MLX74190 device is able to receive and answer SPI commands from the external host MCU.

3.3 Transmission Mode

In TRANSMISSION mode, the MLX74190 is busy transmitting LF sequence(s). All digital outputs are active; the LF driver outputs are configured according to the configuration register active. The SPI interface is activated and the MLX74190 device is able to receive and answer SPI commands from the external host MCU.

3.4 Diagnosis Mode

In DIAGNOSIS mode, the MLX74190 is busy with diagnosis procedure. All digital outputs are set in default states; the LF driver outputs are activated and ready for diagnosis process. The SPI interface is activated and the MLX74190 device is able to receive SPI command from the external host MCU.

4 Device Description

4.1 Power supplies, internal regulation and references

The MLX74190 is supplied with VDD voltage of typically +5V and VS voltage between 6 to 40V, used for the embedded drivers. Both voltages are internally monitored and the MLX74190 device enters the corresponding under-voltage conditions if VDD or VS is going below the VDD_uv or Vs_uv thresholds.

4.2 System clock

The 32MHz internal system clock frequency is generated either from an external 2MHz clock signal provided by an external device (usually coming from a microcontroller) or by using an external crystal resonator whose frequency value is 4MHz. The recognition of the input clock source is done automatically during the start-up phase.

4.3 Low Frequency Generation

The frequency generated by the LF driver can be set to a fixed value of 125 kHz or to a programmable value, from **110 kHz** up to **141.6 kHz**.

4.4 Sine wave generation

In this mode, the generated output is a pure sinus signal, with a **DC** voltage value of **VS/2** and a frequency set according to the frequency generation values described above. The output voltage can also be adjusted from **0.25Vpp** up to **32Vpp**.

4.5 Square wave generation

In this mode, the generated output is a square wave signal with amplitude fixed to the rail-to-rail value of the driver supply voltage VS. The duty-cycle of the square wave signal can be configured to 4 values between **6.25%** up to **50%**.

4.6 Modulator

Each driver stage is able to modulate the LF carrier signal in ASK and PSK mode:

- **ASK:** The amplitude of the carrier frequency is modulated from 0 to 100%
- **PSK:** The phase of the carrier frequency on the output switches between 0° and 180°

4.7 Immobilizer ASK

The ASK demodulator converts the amplitude-modulated analog signal received on ASK_RXi pins from the transponder into digital data which are accessible by the MCU through the D_OUT output pin. The data-rate can be adjusted to 2kbps, 4kbps or 8kbps.

The ASK_RXi inputs are connected to the LF antenna through an external capacitive divider whose value will depend on the antenna quality factor. The capacitive divider should be carefully calculated to avoid entering into the clamping region which would strongly decrease the overall sensitivity.

4.8 Immobilizer FSK

The FSK demodulation block is intended to detect and demodulate the response of the transponder compliant with FSK modulation (frequency shift keying). The demodulated data are accessible by the MCU through the D_OUT output pin. The FSK signal is a modulated frequency signal, where high and low bits are coded with two different frequencies.

The FSK_RXi inputs are connected to the LF antenna through external resistors **Rin** and **Rfb**, which must be adjusted according to the voltage swing on the external antenna.

4.9 Digital SPI Interface

The MLX74190 is interfaced and configured through a standard Serial Peripheral Interface bus (SPI). The communication is full duplex, the host MCU always acts as a Master and the MLX74190 always acts as a slave.

- NCS: Non Chip Select
- SCLK: Serial Clock
- SDI: Serial Data In
- SDO Serial Data Out

4.10 SPI Commands

The MLX74190 is controlled through a set of SPI commands sent by the host MCU. These SPI commands are used to configure the internal registers of the MLX74190.

4.11 Failure Flags

The following failures / warnings are detected by the MLX74190:

- VS/VDD under voltage
- Temperature monitoring (pre-warning & over temperature)
- Antenna over current
- SPI-errors

4.12 Antenna diagnosis

The Diagnosis block is designed to detect any failure related to the antenna connected on the LF driver outputs.

Following potential antenna failures are diagnosed:

- Antenna short circuited to VS/GND
- Disconnected antenna or incorrect Self resonance frequency

4.13 Current Measurement

The current measurement block allows monitoring on time the AC current flowing through the selected Output Antenna Driver. The analog voltage corresponding to the measured current is available on the pin IP_SENSE.

5 Application Information

Typical application schematic is shown below:

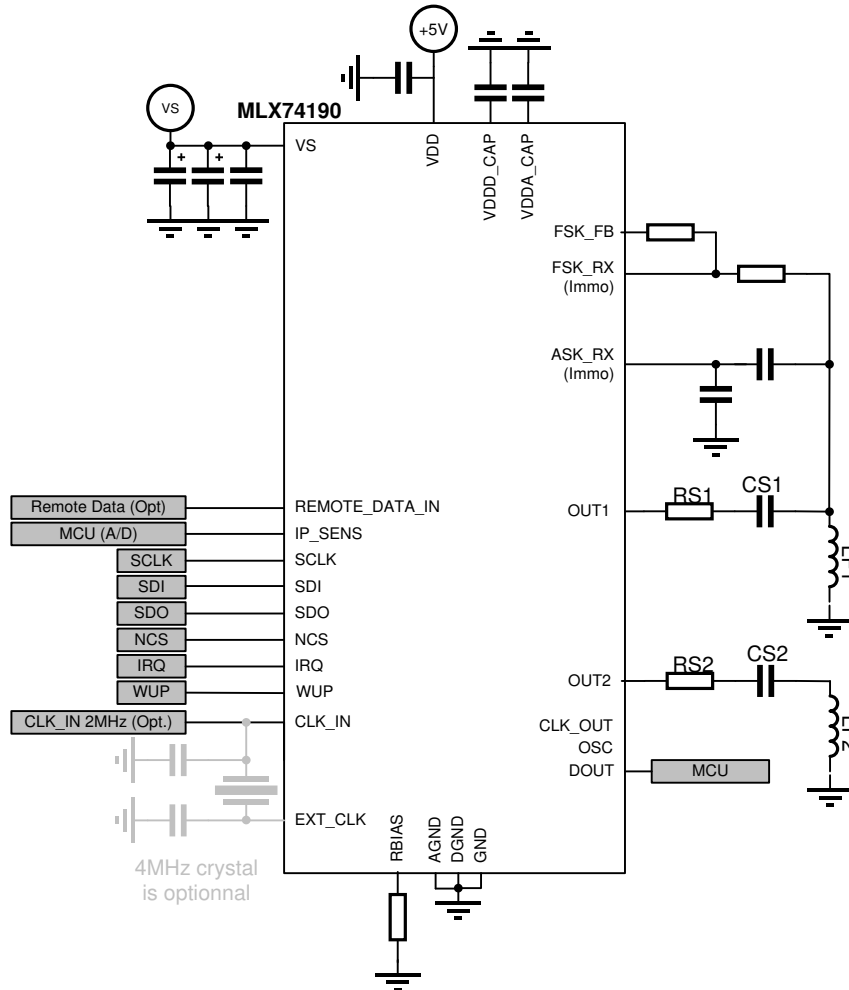

Figure 4: typical application schematic passive start

1 Package and marking information

1.1 Package data TQFP eP 48L (7x7, 48 leads)

	A	A1	A2	b	b1	D	D1	D2	E	E1	E2	e	L	N	ccc	ddd
Min	-	0.05	0.95	0.17	0.17	9.00	7.00	4.00	9.00	7.00	4.00	0.50	0.45	48	-	-
Nom	-	-	1.00	0.22	0.20								0.60		-	-
Max	1.20	0.15	1.05	0.27	0.23								0.75		0.08	0.08

- Notes:
- All Dimensioning and Tolerances conform to ASME Y14.5M-1994.
 - Datum Plane [-|-] located at Mould Parting Line and coincident with Lead, where Lead exists, plastic body at bottom of parting line.
 - Datum [A-B] and [-D-] to be determined at centreline between leads where leads exist, plastic body at datum plane [-|-]
 - To be determined at seating plane [-C-]
 - Dimensions D1 and E1 do not include Mould protrusion. Dimensions D1 and E1 do not include mould protrusion. Allowable mould protrusion is 0.254 mm on D1 and E1 dimensions.
 - 'N' is the total number of terminals
 - These dimensions to be determined at datum plane [-|-]
 - Package top dimensions are smaller than bottom dimensions and top of package will not overhang bottom of package.
 - Dimension b does not include dam bar protrusion, allowable dam bar protrusion shall be 0.08mm total in excess of the "b" dimension at maximum material condition, dam bar can not be located on the lower radius of the foot.
 - Controlling dimension millimetre.
 - maximum allowable die thickness to be assembled in this package family is 0.38mm
 - This outline conforms to JEDEC publication 95 Registration MS-026, Variation ABA, ABC & ABD.
 - A1 is defined as the distance from the seating plane to the lowest point of the package body.
 - Dimension D2 and E2 represent the size of the exposed pad. The actual dimensions are specified on the bonding diagram, and are independent from die size.
 - Exposed pad shall be coplanar with bottom of package within 0.05.

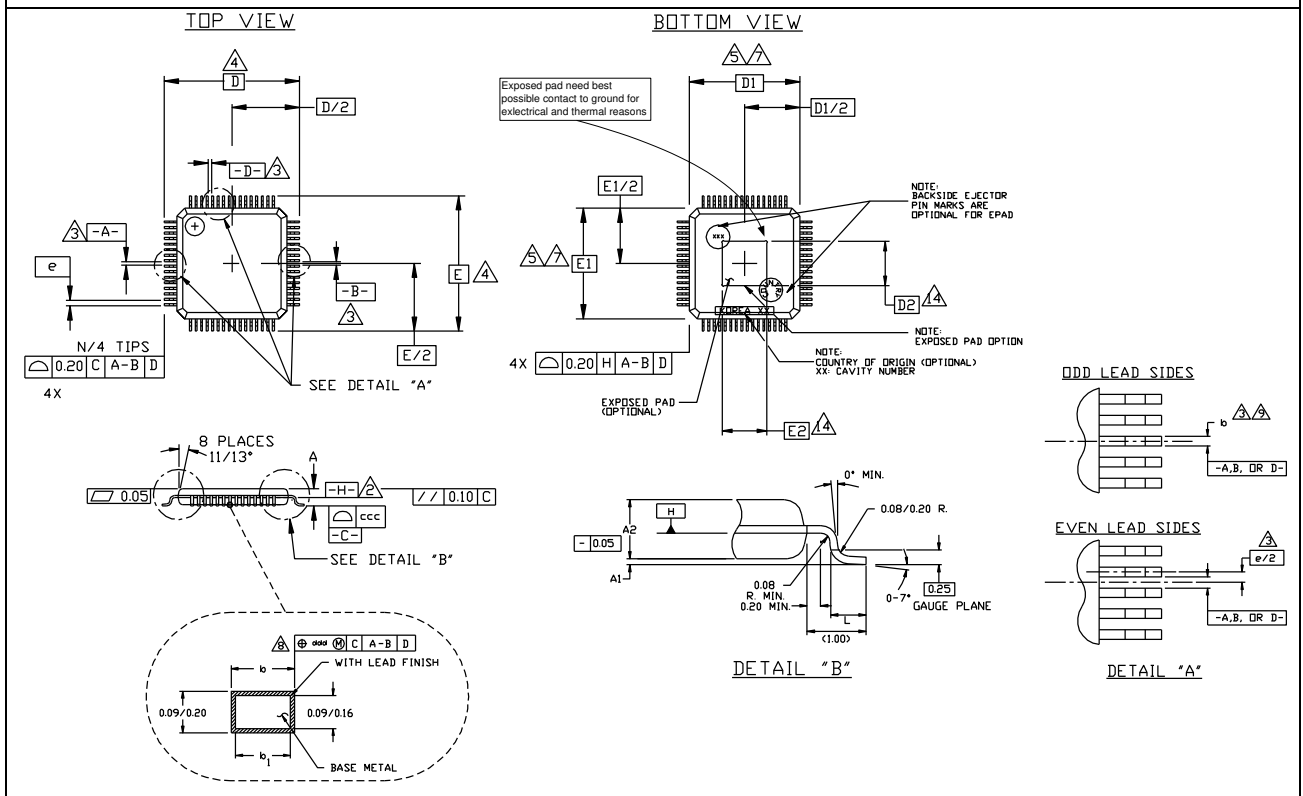

1.2 Marking instruction

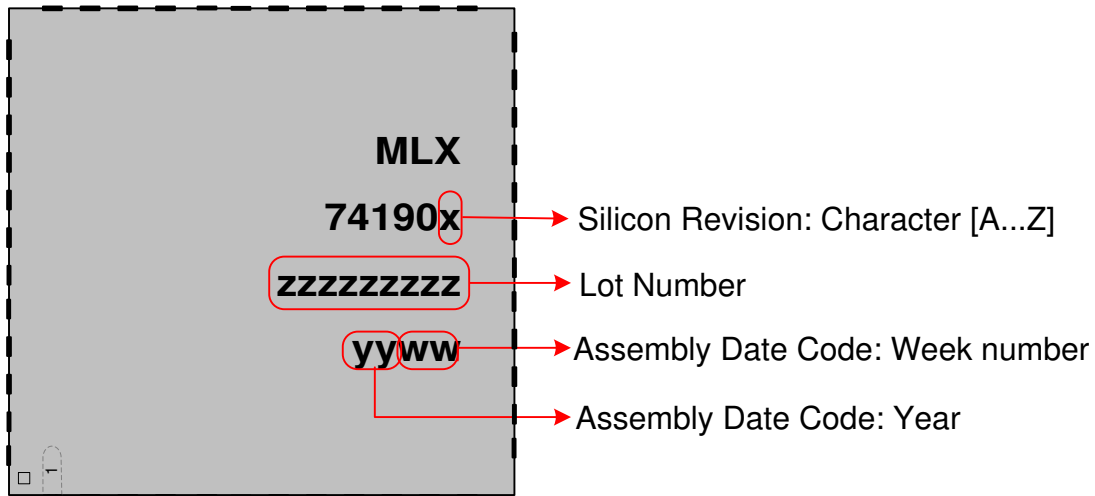

Figure 5: Marking example on IC package TQFP EP 7x7

2 Standard information regarding manufacturability of Melexis products with different soldering processes

Our products are classified and qualified regarding soldering technology, solderability and moisture sensitivity level according to following test methods:

Reflow Soldering SMD's (Surface Mount Devices)

- IPC/JEDEC J-STD-020
Moisture/Reflow Sensitivity Classification for Nonhermetic Solid State Surface Mount Devices (classification reflow profiles according to table 5-2)
- EIA/JEDEC JESD22-A113
Preconditioning of Nonhermetic Surface Mount Devices Prior to Reliability Testing (reflow profiles according to table 2)

Wave Soldering SMD's (Surface Mount Devices) and THD's (Through Hole Devices)

- EN60749-20
Resistance of plastic- encapsulated SMD's to combined effect of moisture and soldering heat
- EIA/JEDEC JESD22-B106 and EN60749-15
Resistance to soldering temperature for through-hole mounted devices

Iron Soldering THD's (Through Hole Devices)

- EN60749-15
Resistance to soldering temperature for through-hole mounted devices

Solderability SMD's (Surface Mount Devices) and THD's (Through Hole Devices)

- EIA/JEDEC JESD22-B102 and EN60749-21
Solderability

For all soldering technologies deviating from above mentioned standard conditions (regarding peak temperature, temperature gradient, temperature profile etc...) additional classification and qualification tests have to be agreed upon with Melexis.

The application of Wave Soldering for SMD's is allowed only after consulting Melexis regarding assurance of adhesive strength between device and board.

Melexis recommends reviewing on our web site the General Guidelines [soldering recommendation \(http://www.melexis.com/Quality_soldering.aspx\)](http://www.melexis.com/Quality_soldering.aspx) as well as [trim&form recommendations \(http://www.melexis.com/Assets/Trim-and-form-recommendations-5565.aspx\)](http://www.melexis.com/Assets/Trim-and-form-recommendations-5565.aspx).

Melexis is contributing to global environmental conservation by promoting **lead free** solutions. For more information on qualifications of **RoHS** compliant products (RoHS = European directive on the Restriction Of the use of certain Hazardous Substances) please visit the quality page on our website: <http://www.melexis.com/quality.aspx>

3 Disclaimer

Devices sold by Melexis are covered by the warranty and patent indemnification provisions appearing in its Term of Sale. Melexis makes no warranty, express, statutory, implied, or by description regarding the information set forth herein or regarding the freedom of the described devices from patent infringement. Melexis reserves the right to change specifications and prices at any time and without notice. Therefore, prior to designing this product into a system, it is necessary to check with Melexis for current information. This product is intended for use in normal commercial applications. Applications requiring extended temperature range, unusual environmental requirements, or high reliability applications, such as military, medical life-support or life-sustaining equipment are specifically not recommended without additional processing by Melexis for each application.

The information furnished by Melexis is believed to be correct and accurate. However, Melexis shall not be liable to recipient or any third party for any damages, including but not limited to personal injury, property damage, loss of profits, loss of use, interrupt of business or indirect, special incidental or consequential damages, of any kind, in connection with or arising out of the furnishing, performance or use of the technical data herein. No obligation or liability to recipient or any third party shall arise or flow out of Melexis' rendering of technical or other services.

© 2014 Melexis NV. All rights reserved.

4 Contact Information

For the latest version of this document, go to our website at:

www.melexis.com

Or for additional information contact Melexis Direct:

Europe, Africa, Asia:

Phone: +32 1367 049

E-mail: sales_europe@melexis.com

America:

Phone: +1 248 306 5400

E-mail: sales_usa@melexis.com

ISO/TS 16949 and ISO14001 Certified