



Chipsmall Limited consists of a professional team with an average of over 10 year of expertise in the distribution of electronic components. Based in Hongkong, we have already established firm and mutual-benefit business relationships with customers from,Europe,America and south Asia,supplying obsolete and hard-to-find components to meet their specific needs.

With the principle of "Quality Parts,Customers Priority,Honest Operation,and Considerate Service",our business mainly focus on the distribution of electronic components. Line cards we deal with include Microchip,ALPS,ROHM,Xilinx,Pulse,ON,Everlight and Freescale. Main products comprise IC,Modules,Potentiometer,IC Socket,Relay,Connector.Our parts cover such applications as commercial,industrial, and automotives areas.

We are looking forward to setting up business relationship with you and hope to provide you with the best service and solution. Let us make a better world for our industry!



## Contact us

Tel: +86-755-8981 8866 Fax: +86-755-8427 6832

Email & Skype: info@chipsmall.com Web: www.chipsmall.com

Address: A1208, Overseas Decoration Building, #122 Zhenhua RD., Futian, Shenzhen, China



## **Advanced Automotive Human-Machine Interfaces Using Optical Technology**

*By Kristof Lieben, Melexis*

*There are a plethora of navigation, comfort, entertainment and safety systems now being incorporated into modern vehicles, whether they are in the luxury, mid-range, or lower end bracket. The need for vehicle occupants to be able to quickly and easily control these systems or access information rapidly is leading to increased focus by automobile manufacturers and their system integrators on implementation of smarter and more intuitive human machine interfaces (HMIs). The following article discusses how optoelectronics will have a role to play in this.*

The increasing density of control functions found in vehicles has meant that dashboard panels consisting solely of mechanical switches are no longer feasible, as having so many switches to deal with will cause driver/passenger confusion. From a manufacturer perspective this is also problematic since, in addition to taking up too much dashboard space and ruining the overall aesthetic, a switch approach does not offer an easy upgrade path - making it difficult to add new features to an existing design.

Car buyers when looking at the latest models on offer will want to be wowed by the breadth of exciting new features and functionality they can utilise through the central console unit. They are now expecting user experiences from these units that are on a par with what they are accustomed in other parts of their everyday life.

As with many other industry sectors, deployment of touchscreen technology is becoming ever more popular in the automotive arena. By 2019, it is predicted that annual global sales of automotive touchscreens will have reached 35.7 million units. However, though this technology is capable of offering highly intuitive HMIs, there are question marks about how appropriate it is for certain tasks within car cabin settings and whether there is a need to supplement it with an

additional detection system. The issue of safety has often been brought up with regard to touch-based control systems. As a result a number of alternative methods are being considered for certain elements of vehicles' HMI implementations.

In the United States, the National Highway Traffic Safety Administration (NHTSA) has carried out considerable research with regard to the issue of driver distractions. It has defined two fundamental components that influence it.

1. The amount of attention, in terms of the driver's visual, cognitive, manual resources, required to perform the task.
2. How the driver will have to perform this task while driving.

The Alliance of Automobile Manufacturers has set guidelines stating that "Systems with visual displays should be designed such that the driver can complete the desired task with sequential glances that are brief enough not to adversely affect driving." Though a touch-based approach is highly suitable for portable consumer devices like tablet computers, within an automotive environment, in some cases the level of concentration needed to carry out a task by operating a touch-enabled display can be too high. With this in mind, leading car brands are keen to augment the touch control system so that any risk of driver distraction occurring is avoided.

Employing voice recognition in the duty is an option, but this has its drawbacks. Though voice recognition systems have improved greatly in recent years, they can still make errors and this can lead to user frustration. How frequently errors occur will relate very closely to the level of background noise. Clearly the interior of a vehicle will have a considerable amount of background noise present. In addition, region accents and variations in speech will have an effect.

Optical technology can be highly effective for supplementing touch-based HMIs. This presents engineers with a way to implement a sensing mechanism that is completely touch-less.

Applications for this technology include, but are not limited to:

- Proximity detection
- Simple gesture recognition, like left/right swipe



- Driver/passenger discrimination, e.g. to infotainment options that are deemed to be too distracting for the driver – only allowing the passenger to access them.

There are a number of challenges that need to be tackled when creating systems of this kind though. An optically-based HMI solution will therefore need to have the following attributes:

1. The ability to cope with wide variation in background light levels.
2. A strong resilience to electro-magnetic interference (EMI).
3. Support for multiple OEM configurations.
4. A low bill of materials.
5. Takes up minimal board real estate.
6. The ability to deal with severe mechanical integration constraints.

In response to its customers' demands for a viable optically-based automotive HMI without the shortfalls that are inherent in alternative systems, the engineering team at Melexis has developed a series of highly robust sensor interface ICs. Based on CMOS process technology, the company's MLX75030 and MLX75031 proximity and gesture detection ICs feature its proprietary integrated ambient light suppression technology, making them highly tolerant to the effects of static and dynamically varying background light. Furthermore it has proven electro-magnetic compliance, plus a small footprint that is highly suited to space-constrained user interface designs.

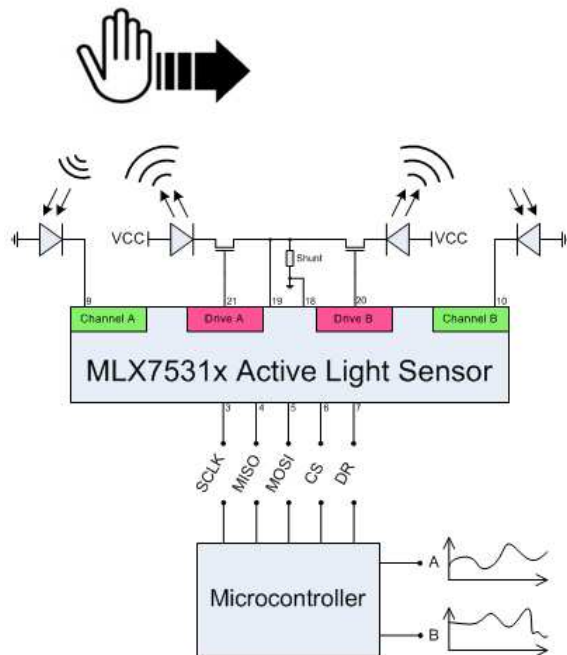

**Figure 1: Basic Structure for Automotive HMI using an MLX7503x device**

The MLX7503x series of sensor ICs enable easy implementation of multi-channel, close range optical sensing systems. Each IC has two independent, simultaneously operating light measurement channels. These can be assigned to detect the active optical reflection from a target (i.e. the user's hand). The built-in ambient light suppression mechanism makes these channels invulnerable to light interference.

Figure 1 shows the basic structure of a HMI based on the MLX7503x. The LEDs emit a short pulse train, the light reflected off the user's hand is detected by the photodiode, while the background light is rejected in hardware and the current from the photodiode is converted to a 16-bit digital signal. The mechanical integration issue is covered as the required electronics does not impose on the console design - only the LEDs and the photodiodes need to be on the front surface of the console, everything else can be put wherever there is available space behind the console.



**Figure 2: The Melexis MLX75030**

The MLX75030 allows external switches to drive the LEDs up to a peak current of 1 A, while the MLX75031 has LED driver functionality built in, in order to minimise the additional components needed and thereby lower the bill of materials. Internal control logic, configurable user registers and a SPI interface enable simple, fully programmable operation. A 16-bit ADC incorporated into each of these ICs allows creation of a digital output. The digital data on the measured active light and ambient light levels is passed to the system microcontroller, where it can be processed (a measurement rate of up to 700 Hz per measurement channel allows smooth interface response times). Then, via software algorithms on an external microcontroller, the system can distinguish between different gestures (e.g. left/right/up/down swipes and circular movements). As ambient light has already been factored out by the interface IC, the microcontroller's processing resources can be focussed on its other responsibilities.

Optically-based proximity sensing presents the automotive industry with a way to augment touchscreen HMIs and infotainment control elements. This technology allows simple gestures to be distinguished while ensuring against driver distraction. Drivers can thus regularly engage in certain tasks while driving without the safety of them or their fellow vehicle occupants being compromised. Moving forward it is possible that, once users are more familiar with this technology, automobile manufacturers might start to adopt an all-optical approach to HMIs with higher performance optical implementations replacing costly multi-touch touch screens.