



Chipsmall Limited consists of a professional team with an average of over 10 year of expertise in the distribution of electronic components. Based in Hongkong, we have already established firm and mutual-benefit business relationships with customers from,Europe,America and south Asia,supplying obsolete and hard-to-find components to meet their specific needs.

With the principle of “Quality Parts,Customers Priority,Honest Operation,and Considerate Service”,our business mainly focus on the distribution of electronic components. Line cards we deal with include Microchip,ALPS,ROHM,Xilinx,Pulse,ON,Everlight and Freescale. Main products comprise IC,Modules,Potentiometer,IC Socket,Relay,Connector.Our parts cover such applications as commercial,industrial, and automotives areas.

We are looking forward to setting up business relationship with you and hope to provide you with the best service and solution. Let us make a better world for our industry!



## Contact us

Tel: +86-755-8981 8866 Fax: +86-755-8427 6832

Email & Skype: info@chipsmall.com Web: www.chipsmall.com

Address: A1208, Overseas Decoration Building, #122 Zhenhua RD., Futian, Shenzhen, China



### Features

- LIN 2.x / SAE J2602 compliant
- Operating voltage  $V_{SUP} = 5 \dots 27 \text{ V}$
- 3 modes: Normal, Silent and Sleep
- Linear low drop voltage regulator:
  - MLX80030/31:
    - Normal mode 3.3V/70mA  $\pm 2\%$
    - Silent mode 3.3V/20mA  $\pm 2\%$
  - MLX80050/51:
    - Normal mode 5V/70mA  $\pm 2\%$
    - Silent mode 5V/20mA  $\pm 2\%$
- Low current consumption (typ)
  - Sleep mode 20  $\mu\text{A}$
  - Silent mode "noload" 45  $\mu\text{A}$
- Output current limitation
- LIN-Bus Transceiver
  - Baud rate up to 20 kBaud
  - Slew rate control for best EME behaviour
  - Low slew mode for optimized SAE J2602 transmission
  - High impedance LIN pin in case of loss of ground or battery
  - Bus input voltages -24V to 30V independent from VBat
- Remote and local wake up source recognition
- VCC undervoltage detection at NRES output (start-up delay 4ms)
  - Vres threshold 3.0 V (MLX80030/31); Vres threshold 4.1V (MLX80050/51)
- Programmable Window Watchdog (only MLX80031/51)
- VSUP undervoltage detection (POR), Over temperature shutdown
- TxD dominant time out function, Standby mode time out after 350ms
- Automotive temperature range of  $-40^{\circ}\text{C}$  to  $125^{\circ}\text{C}$
- Interface I/O's independent from voltage regulator output
- Enhanced ESD robustness according to IEC 61000-4-2
  - Direct discharge for pin LIN >20kV (only Lin cap connected) and for pin VBAT >15kV
  - Indirect discharge for pin LIN >15kV
- Load dump protected (40V)

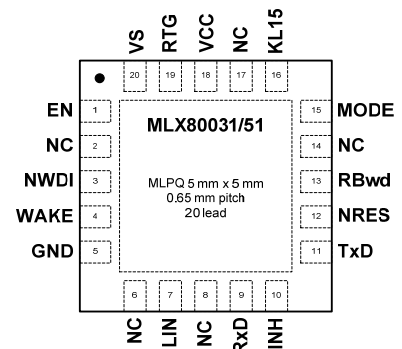
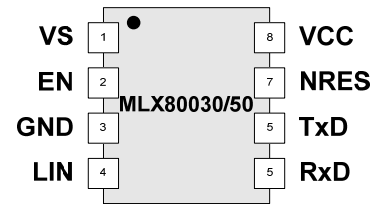

Order Code	Temp. Range	Package	Delivery	Remark
MLX80050 KDC-BAA-000-RE	-40 - 125 °C	SOIC8	Reel	
MLX80051 KLQ-BAA-000-RE	-40 - 125 °C	QFN 5x5	Reel	
MLX80030 KDC-BAA-000-RE	-40 - 125 °C	SOIC8	Reel	
MLX80031 KLQ-BAA-000-RE	-40 - 125 °C	QFN 5x5	Reel	

### Short Description

The MLX8005x/3x consist of a low-drop voltage regulator 5V/3.3V/70mA combined with a Reset/Watchdog unit and a LIN bus transceiver. The LIN transceiver is suitable for LIN bus systems conform to LIN specification revision 2.x and SAE J2602. The watchdog times of the integrated window watchdog can be adapted on application needs via external resistors. With the help of an external bipolar transistor it is possible to extend the output current of the integrated voltage regulator. The combination of voltage regulator and bus transceiver as well as watchdog unit makes it possible to develop simple, but powerful and cheap slave nodes in LIN Bus systems.

## Contents

<b>LIST OF TABLES</b> .....	4
<b>LIST OF FIGURES</b> .....	4
<b>1. ELECTRICAL SPECIFICATION</b> .....	5
1.1. DC CHARACTERISTICS .....	6
1.2. AC CHARACTERISTICS .....	11
1.3. TIMING DIAGRAMS .....	14
<b>2. PIN CONFIGURATION</b> .....	15
2.1. MLX80030 AND MLX80050 - SOIC8.....	15
2.2. MLX80031 AND MLX80051 IN QFN20 .....	16
<b>3. FUNCTIONAL DESCRIPTION</b> .....	17
3.1. SUPPLY PIN VS .....	19
3.2. EN INPUT PIN.....	19
3.3. GROUND PIN GND .....	19
3.4. LIN .....	19
3.5. RECEIVER OUTPUT RXD .....	19
3.6. TRANSMIT INPUT TXD .....	19
3.6.1. TxD dominant time-out feature .....	19
3.7. OUTPUT NRES.....	20
3.8. VOLTAGE REGULATOR PINS VCC AND RTG.....	20
3.9. INH OUTPUT (ONLY MLX80031/51).....	20
3.10. WAKE INPUT (ONLY MLX80031/51).....	20
3.11. KL15 INPUT (ONLY MLX80031/51) .....	20
3.12. WATCHDOG TRIGGER INPUT NWDI (ONLY MLX80031/51).....	20
3.13. WATCHDOG OSCILLATOR RESISTOR RB <sub>WD</sub> (ONLY MLX80031/51).....	20
3.14. MODE INPUT MODE (ONLY MLX80031/51).....	20
<b>4. OPERATIONAL MODES</b> .....	21
4.1. MODES OVERVIEW.....	22
4.2. INITIALISATION AND STANDBY MODE .....	23
4.3. NORMAL MODE .....	23
4.4. SILENT MODE .....	24
4.5. SLEEP MODE .....	25
4.6. INIT-STATE .....	27
<b>5. WAKE UP PROCEDURES</b> .....	28
5.1. WAKE UP SOURCE RECOGNITION IN MLX80031/51 .....	28
<b>6. FUNCTIONALITY</b> .....	29
6.1. RESET BEHAVIOUR OF MLX8003x/5x .....	29
6.2. THERMAL SHUTDOWN .....	29
6.3. VS UNDER VOLTAGE RESET .....	30
6.4. LIN-TRANSCEIVER .....	30
6.5. VOLTAGE REGULATOR .....	31
<b>7. WINDOW-WATCHDOG (ONLY MLX80031/51)</b> .....	32
7.1. MLX80031/51 WATCHDOG BEHAVIOUR .....	32
7.2. ALL WATCHDOG START-UP SCENARIOS .....	33
7.2.1. After power-on and initialization .....	33
7.2.2. Wake up indicated transition to Standby Mode from Sleep or Silent Mode .....	33

7.2.3. Undervoltage reset on VCC on Normal Mode or Silent Mode.....	33
7.2.4. EN indicated transition from Silent Mode to Normal Mode.....	33
7.3. CALCULATION OF WATCHDOG PERIOD .....	34
<b>8. FAIL-SAFE FEATURES .....</b>	<b>36</b>
<b>9. APPLICATION HINTS.....</b>	<b>37</b>
9.1. SAFE OPERATING AREA .....	37
9.2. APPLICATION CIRCUITRY .....	38
9.2.1. EMI Suppressing .....	39
9.2.2. EMC disturbances using the example of MLX80030/50 .....	39
<b>10. MECHANICAL SPECIFICATION .....</b>	<b>41</b>
10.1. SOIC8 PACKAGE .....	41
10.2. QFN20 5X5 PACKAGE.....	42
<b>11. REVISION HISTORY .....</b>	<b>43</b>
<b>12. STANDARD INFORMATION REGARDING MANUFACTURABILITY OF MELEXIS PRODUCTS WITH DIFFERENT SOLDERING PROCESSES .....</b>	<b>45</b>
<b>13. DISCLAIMER.....</b>	<b>46</b>

### List of Tables

Table 1: Absolute maximum ratings .....	5
Table 2: Voltage Regulator and Reset Unit.....	6
Table 3: LIN DC Characteristics .....	10
Table 4: AC Characteristics.....	11
Table 5: MLX80050/30 pin list in SOIC8 .....	15
Table 6: MLX80051/31 pin list in QFN20.....	16
Table 7: MLX80050/30 Operation Modes .....	22
Table 8: MLX80051/31 Operation Modes .....	22
Table 9: Parameters of Window Watchdog.....	35
Table 10: Window Watchdog Timing Selection.....	35
Table 11: Parameter ranges for function state A (MLX80050).....	40
Table 12: SOIC8 dimensions.....	41
Table 13: QFN20 Package Dimensions .....	42

### List of Figures

Figure 1: LIN propagation delays .....	14
Figure 2: LIN duty cycles .....	14
Figure 3: MLX80050/30 Block Diagram.....	17
Figure 4: MLX80051/31 Block Diagram.....	18
Figure 5: MLX8005x3x state diagram of modes of operation .....	21
Figure 6: LIN wake-up from Silent Mode .....	24
Figure 7 Local Wake-up from Silent Mode via WAKE.....	25
Figure 8: Remote wake-up from Sleep Mode.....	26
Figure 9: Local wake-up from Sleep Mode.....	27
Figure 10: VCC reset behavior .....	29
Figure 11: MLX80031/51 Watchdog behavior.....	32
Figure 12: Watchdog timing.....	33
Figure 13: Watchdog open and close window tolerances.....	34
Figure 14: Safe operating area for MLX80030/50 in SOIC-8 for Vsup up to 18V .....	37
Figure 15: Safe operating area for MLX80031/51 in QFN20 for Vsup up to 18V .....	38
Figure 16: Application circuit with MLX80050 or MLX80030 (slave node).....	38
Figure 17: Application circuit with MLX80031 or MLX80051 (slave node).....	39
Figure 18: Part of test circuitry for EMC tests with MLX80030/50.....	40
Figure 19: SOIC8 Drawing .....	41
Figure 20: QFN20 Drawing.....	42

### 1. Electrical Specification

All voltages are referenced to ground (GND), positive currents flow into the IC.

#### Absolute Maximum Ratings

**Table 1: Absolute maximum ratings**

Parameter	Symbol	Condition	Min	Max	Unit
Supply voltage at VS	V <sub>S</sub>	Respective to GND	-0.3	40	V
Transient voltage ISO 7637/2		pulse 1, 2	-100	100	V
Transient voltage ISO 7637/2		pulse 3A; 3B, coupling 1nF	-150	100	V
DC voltage LIN	V <sub>LIN_DC</sub>	Respective to GND and VS Loss of Ground (VGND = VS)	-20 -30	40 40	V
DC voltage WAKE	V <sub>WAKE_DC</sub>	Respective to GND and VS Loss of Ground (VGND = VS)	-20 -30	40 40	V
DC voltage INH	V <sub>INH_DC</sub>		-0.3	V <sub>S</sub> +0.3	V
DC voltage VCC	V <sub>VCC_DC</sub>		-0.3	7	V
DC voltage RTG	V <sub>RTG_DC</sub>		-0.3	7	V
Input voltage at low voltage I/O's (EN, TxD, RxD, NRES, WDI, RB <sub>WD</sub> )	V <sub>IN</sub>		-0.3	7	V
ESD voltage	V <sub>ESDIEC</sub>	IEC 61000-4-2, direct ESD Pin LIN with LIN cap 220pF Pin VS to GND	20 15		kV
	V <sub>ESDIECind</sub>	IEC 61000-4-2, indirect ESD Pin LIN with LIN cap 220pF	15		kV
	V <sub>ESDHBM</sub>	HBM (CDF-AEC-Q100-002) Pin LIN Pin WAKE, KL15, VS Other pins	±6 ±4 ±2		kV kV kV
	V <sub>ESDCDM</sub>	CDM (AEC-Q100-011)	±500		V
Power dissipation	P <sub>0</sub>		Internal limited see also chapter 9.1		
Thermal resistance from junction to ambient	R <sub>THJA_SOIC8</sub>	JEDEC 1s0p board, no air flow		150	K/W
	R <sub>THJA_QFN20</sub>	JEDEC 1s0p board, no air flow		50	K/W
Junction temperature	T <sub>J</sub>		-40	150	°C
Storage temperature	T <sub>STG</sub>		-55	150	°C

### 1.1. DC Characteristics

Unless otherwise specified all values in the following tables are valid for  $V_S = 5$  to 27V and  $T_{AMB} = -40$  to 125°C. All voltages are referenced to ground (GND), positive currents flow into the IC. For MLX80031/51 apply: RTG connected to VCC.

**Table 2: Voltage Regulator and Reset Unit**

	Parameter	Symbol	Condition	Min	Typ	Max	Unit	T <sup>[1]</sup>
<b>Supply Voltage Pin VS</b>								
	Nominal DC operating voltage	$V_S$		5		27	V	A
1.01	$V_S$ under voltage reset	$V_{SUVR\_OFF}$	$V_S$ ramp up	2.9		4.6	V	A
1.02	$V_S$ under voltage reset	$V_{SUVR\_ON}$	$V_S$ ramp down	2.4		4.2	V	A
1.03	$V_S$ under voltage reset hysteresis	$V_{SUVR\_HYS}$	$V_{SUVR\_OFF} - V_{SUVR\_ON}$	0.04	0.3	0.7	V	A
<b>Supply currents MLX80030, MLX80050</b>								
2.00	Supply current, normal mode	$I_{VS\_nor}$	$V_S \leq 14V, V_{EN} > 2V$ , LIN recessive, no load at VCC	400	750	1500	$\mu A$	A
2.01	Supply current, sleep mode	$I_{VS\_sleep}$	$V_S \leq 14V$ $T_A = 25^\circ C$ $-40^\circ C \leq T_A \leq 125^\circ C$		20	20 30	$\mu A$	A
2.02	Supply current, silent mode	$I_{VS\_sil}$	$V_S \leq 14V$ , LIN recessive no load at VCC $T_A = 25^\circ C$ $-40^\circ C \leq T_A \leq 125^\circ C$	20	45	65 85	$\mu A$	A
<b>Supply currents MLX80031, MLX80051</b>								
2.00	Supply current, normal mode [2]	$I_{VS\_nor}$	$V_S \leq 14V, V_{EN} > 2V, R_{BWD} = 60k$ LIN recessive, no load at VCC	400	750	1500	$\mu A$	A
2.01	Supply current, sleep mode	$I_{VS\_sleep}$	$V_S \leq 14V$ $T_A = 25^\circ C$ $-40^\circ C \leq T_A \leq 125^\circ C$		20	20 30	$\mu A$	A
2.02	Supply current, silent mode	$I_{VS\_sil}$	$V_S \leq 14V$ , LIN recessive no load at VCC $T_A = 25^\circ C$ $-40^\circ C \leq T_A \leq 125^\circ C$	20	45	65 85	$\mu A$	A

	Parameter	Symbol	Condition	Min	Typ	Max	Unit	T <sup>[1]</sup>
<b>Voltage Regulator Pin VCC</b>								
<b>MLX80050, MLX80051 (RTG connected to VCC)</b>								
3.01	Output voltage VCC	V <sub>CCn5</sub>	6V ≤ V <sub>S</sub> ≤ 18V 1mA ≤ I <sub>LOAD</sub> ≤ 70mA T <sub>A</sub> = 25°C T <sub>A</sub> = -40°C to 125°C	4.90 4.85	5.0	5.10 5.15	V	A
	Output voltage VCC under disturbances to fulfil functional state A	V <sub>CCndis5</sub>	6V ≤ V <sub>S</sub> ≤ 18V, T <sub>A</sub> = 25°C R <sub>LOAD</sub> = 330 Ω	4.75		5.25	V	C
3.02	Drop-out voltage <sup>[3]</sup>	V <sub>D10_5</sub>	V <sub>S</sub> > 4V, I <sub>VCC</sub> = 10mA		75	120	mV	A
3.03		V <sub>D30_5</sub>	V <sub>S</sub> > 4V, I <sub>VCC</sub> = 30mA		220	350	mV	A
3.04		V <sub>D70_5</sub>	V <sub>S</sub> > 4V, I <sub>VCC</sub> = 70mA		500	800	mV	A
3.05	Line regulation	V <sub>LNRS</sub>	6V ≤ V <sub>S</sub> ≤ 18V			20	mV	C
3.06	Load regulation	V <sub>LDR10_5</sub>	1 mA < I <sub>LOAD</sub> < 10 mA			50	mV	A
3.07		V <sub>LDR30_5</sub>	1 mA < I <sub>LOAD</sub> < 30 mA			90	mV	A
3.08		V <sub>LDR70_5</sub>	1 mA < I <sub>LOAD</sub> < 70 mA			150	mV	A
3.09	Output current limitation	I <sub>VCCCLIM_5</sub>	V <sub>S</sub> > 6V T <sub>A</sub> = -40 °C 25 °C ≤ T <sub>A</sub> ≤ 125 °C	-135 -150	-110	-75 -80	mA	A
3.10	Load capacity	C <sub>LOAD</sub>		2.2	22		μF	D
<b>MLX80030, MLX80031 (RTG connected to VCC)</b>								
3.01	Output voltage VCC	V <sub>CCn3</sub>	4 V ≤ V <sub>S</sub> ≤ 18 V 1mA ≤ I <sub>LOAD</sub> ≤ 70 mA T <sub>A</sub> = 25 °C T <sub>A</sub> = -40 °C to 125 °C	3.234 3.201	3.3	3.366 3.399	V	A
	Output voltage VCC under disturbances to fulfil functional state A	V <sub>CCndis3</sub>	6 V ≤ V <sub>S</sub> ≤ 18 V, T <sub>A</sub> = 25 °C R <sub>LOAD</sub> = 330 Ω	3.135		3.465	V	C
3.02	Drop-out voltage <sup>[3]</sup>	V <sub>D10_3</sub>	V <sub>S</sub> > 3 V, I <sub>VCC</sub> = 10 mA			100	mV	A
3.03		V <sub>D30_3</sub>	V <sub>S</sub> > 3 V, I <sub>VCC</sub> = 30 mA			300	mV	A
3.04		V <sub>D70_3</sub>	V <sub>S</sub> > 3 V, I <sub>VCC</sub> = 70 mA			700	mV	A
3.05	Line regulation	V <sub>LNRS</sub>	5 V ≤ V <sub>S</sub> ≤ 18 V			20	mV	A
3.06	Load regulation	V <sub>LDR10_3</sub>	1 mA < I <sub>LOAD</sub> < 10 mA			50	mV	A
3.07		V <sub>LDR30_3</sub>	1 mA < I <sub>LOAD</sub> < 30 mA			90	mV	A
3.08		V <sub>LDR70_3</sub>	1 mA < I <sub>LOAD</sub> < 70 mA			150	mV	A
3.09	Output current limitation	I <sub>VCCCLIM_3</sub>	V <sub>S</sub> > 4 V T <sub>A</sub> = -40 °C 25 °C ≤ T <sub>A</sub> ≤ 125 °C	-135 -150	-110	-75 -80	mA	A
3.10	Load capacity	C <sub>LOAD</sub>		2.2	22		μF	D



	Parameter	Symbol	Condition	Min	Typ	Max	Unit	T <sup>[1]</sup>
<b>Output Pin NRES</b>								
4.01	Output voltage low	V <sub>OL_NRES</sub>	I <sub>NRES</sub> = 2 mA			0.4	V	A
4.02	Leakage current low	I <sub>leak_RxD</sub>	V <sub>NRES</sub> = 0 V	-5		5	μA	A
4.03	Leakage current high	I <sub>leak_RxD</sub>	V <sub>NRES</sub> = V <sub>CC</sub>	-5		5	μA	A
	Output voltage high NRES under disturbances to fulfil functional state A <sup>[4]</sup>	V <sub>OH_NRES</sub>	R <sub>load</sub> = 2.7 k to V <sub>CC</sub>	V <sub>CC</sub> -1			V	C
<b>MLX80050, MLX80051</b>								
5.01	V <sub>CC</sub> reset threshold on NRES pin	V <sub>RES5V</sub>	t > t <sub>tr</sub>	3.9	4.10	4.3	V	A
5.02	V <sub>RES</sub> Hysteresis V <sub>RESHYS</sub> =  V <sub>RES(ON)</sub> - V <sub>RES(OFF)</sub>	V <sub>RESHYS5V</sub>				200	mV	C
<b>MLX80030, MLX80031</b>								
5.01	V <sub>CC</sub> reset threshold on NRES pin	V <sub>RES3V</sub>	t > t <sub>tr</sub>	2.75	2.95	3.15	V	A
5.02	V <sub>RES</sub> Hysteresis V <sub>RESHYS</sub> =  V <sub>RES(ON)</sub> - V <sub>RES(OFF)</sub>	V <sub>RESHYS3V</sub>				100	mV	C
<b>Input Pin EN</b>								
6.01	Input voltage low	V <sub>IL_EN</sub>				0.8	V	A
6.02	Input voltage high	V <sub>IH_EN</sub>		2.0			V	A
6.03	Hysteresis	V <sub>HYS_EN</sub>		50	100	700	mV	C
6.04	Pull-down resistor	R <sub>pd_EN</sub>	V <sub>EN</sub> = V <sub>CC</sub>	50	125	250	kΩ	A
<b>Input Pin WAKE (MLX80031, MLX80051)</b>								
7.01	High level input voltage	V <sub>IH_WAKE</sub>	Sleep mode	V <sub>S</sub> -1V			V	A
7.02	Low level input voltage	V <sub>IL_WAKE</sub>	Sleep mode			V <sub>S</sub> -3.3V	V	A
7.03	Pull up current WAKE	I <sub>WAKE_PU</sub>	Normal & sleep	-30	-15	-1	μA	A
7.04	Leakage current WAKE high	I <sub>WAKE_IK</sub>	V <sub>S</sub> = 18V	-5		5	μA	A
<b>Input Pin KL15 (MLX80031, MLX80051)</b>								
8.01	High level input voltage	V <sub>IH_KL15</sub>	R <sub>v</sub> = 50kΩ	4		V <sub>S</sub> +0.3V	V	A
8.02	Low level input voltage	V <sub>IL_KL15</sub>	R <sub>v</sub> = 50kΩ	-1		2	V	A
8.03	Pull down current KL15	I <sub>KL15_PD</sub>			30	65	μA	A
<b>Input Pin MODE (MLX80031, MLX80051)</b>								
23.01	Input voltage low	V <sub>IL_MODE</sub>				0.8	V	A
23.02	Input voltage high	V <sub>IH_MODE</sub>		2.0			V	A
23.03	Hysteresis	V <sub>HYS_MODE</sub>		50	100	700	mV	C
23.04	Pull-down resistor	R <sub>pd_MODE</sub>	V <sub>MODE</sub> = V <sub>CC</sub>	200		250	kΩ	A

	Parameter	Symbol	Condition	Min	Typ	Max	Unit	T <sup>[1]</sup>
<b>Input Pin NWDI (MLX80031, MLX80051)</b>								
9.01	Input voltage low	V <sub>IL_NWDI</sub>				0.8	V	A
9.02	Input voltage high	V <sub>IH_NWDI</sub>		2.0			V	A
9.03	Hysteresis	V <sub>HYS_NWDI</sub>		50	100	600	mV	C
9.04	Pull-up resistor to VCC	R <sub>pu_NWDI</sub>	V <sub>NWDI</sub> = 0V	125	250	375	kΩ	A
<b>Watchdog Oscillator pin RB<sub>WD</sub> (MLX80031, MLX80051)</b>								
10.01	Voltage at RB <sub>WD</sub>	V <sub>RBwd</sub>	I <sub>OUT</sub> = -50 μA		1.2		V	A
10.02	Range of RB <sub>WD</sub> resistance	RB <sub>WD</sub>		20		150	kΩ	B
10.03	RB <sub>WD</sub> short resistance to disable Watchdog	RB <sub>WDSH</sub>	Watchdog disabled	0		330	Ω	B
<b>Output INH (MLX80031, MLX80051)</b>								
11.01	ON Resistance	R <sub>ON_INH</sub>	V <sub>S</sub> = 12V		20	50	Ω	A
11.02	Leakage current INH high	I <sub>leakH_INH</sub>	Sleep Mode, V <sub>INH</sub> = 18V, V <sub>S</sub> = 18V	-5		5	μA	A
11.03	Leakage current INH low	I <sub>leakL_INH</sub>	Sleep Mode, V <sub>INH</sub> = 0V, V <sub>S</sub> = 18V	-5		5	μA	A
<b>Thermal Protection</b>								
	Thermal shutdown	T <sub>JSHD</sub>		155	170	190	°C	D
	Thermal hysteresis	T <sub>JHYS</sub>			10	30	°C	D

**Table 3: LIN DC Characteristics**

Parameter	Symbol	Condition	Min	Typ	Max	Unit	T <sup>[1]</sup>	
<b>General</b>								
12.01	Pull up current LIN (recessive)	$I_{INLINpu}$	$V_{LIN} = 18V, V_S = 6V$			80	$\mu A$	A
12.02	Pull up resistor LIN	$R_{LINpu}$	$V_S = 12V, V_{LIN} = 0V$	20	30	60	$k\Omega$	A
12.03	Reverse current LIN (dominant)	$I_{INLINdom}$	$V_S = 12V, V_{LIN} = 0V$	-400			$\mu A$	A
12.04	Reverse current LIN (recessive)	$I_{INLINrec}$	$V_{LIN} \geq V_S, 8V \leq V_{LIN} \leq 18V, 8V \leq V_S \leq 18V$	0		23	$\mu A$	A
12.05	Reverse current LIN (loss of battery)	$I_{INLIN_{job}}$	$V_S = 0V, 0V \leq V_{LIN} \leq 18V$	0		23	$\mu A$	A
12.06	Reverse current LIN (loss of ground)	$I_{INLIN_{log}}$	$V_S = 12V, 0V \leq V_{LIN} \leq 18V$	-10		50	$\mu A$	A
	Voltage drop serial Diode	$V_{SerDiode}$		0.4	0.7	1.0	V	D
	Battery Shift	$V_{Shift\_BAT}$		0		11.5	%	D
	Ground Shift	$V_{Shift\_GND}$		0		11.5	%	D
	Ground-Battery shift difference	$V_{Shift\_diff}$		0		8	%	D
<b>Receiver</b>								
12.07	Receiver dominant voltage	$V_{BUSdom}$	$7.0V \leq V_S \leq 18V$			$0.4 \cdot V_S$	V	A
	Receiver recessive voltage	$V_{BUSrec}$		$0.6 \cdot V_S$				A
12.08	Centre point of receiver threshold $V_{thr\_cnt} = (V_{thr\_rec} + V_{thr\_dom})/2$	$V_{thr\_cnt}$		$0.475 \cdot V_S$	$0.5 \cdot V_S$	$0.525 \cdot V_S$		A
12.09	Receiver Hysteresis $V_{hys} = V_{thr\_rec} - V_{thr\_dom}$	$V_{hys}$			$0.15 \cdot V_S$	$0.175 \cdot V_S$		A
<b>Transmitter</b>								
12.10	Transmitter dominant voltage	$V_{olbus}$	$R_{load} = 500\Omega, V_S = 5V$	0		1.2	V	D
			$R_{load} = 500\Omega, V_S \geq 7V$	0		$0.2 \cdot V_S$		A
12.11	Current limitation LIN	$I_{LIM}$	$V_{LIN} = V_S, TxD = 0V$	40	120	200	mA	A
12.12	Transmitter recessive voltage	$V_{ohBUS}$	No load, $V_{EN} = 0/5V, V_{TxD} = 5V$	$0.8 \cdot V_S$		$V_S$	V	A

Parameter	Symbol	Condition	Min	Typ	Max	Unit	T <sup>[1]</sup>
<b>Input/Output Pin TxD</b>							
13.01	Input voltage low TxD	$V_{IL\_TxD}$	rising			0.8	V A
13.02	Input voltage high TxD	$V_{IH\_TxD}$		2			V A
13.03	Hysteresis	$V_{HYS\_TxD}$		50		700	mV C
13.04	Pull-up resistor to VCC	$R_{pu\_TxD}$	$V_{TxD} = 0V$	125	250	375	k $\Omega$ A
13.06	Low level output current	$I_{OL\_TxD}$	local wake-up request; standby mode; $V_{TxD} = 0.4V$	1.5			mA A
<b>Output Pin RxD</b>							
14.01	Output voltage low RxD	$V_{OL\_RxD}$	$I_{RxD} = 2\text{ mA}$			0.6	V A
14.02	Pull-up resistor to VCC	$R_{pu\_RxD}$	$V_{RxD} = 0V$	3	5	7	k $\Omega$ A
14.03	Leakage current high	$I_{leak\_RxD}$	$V_{RxD} = V_{CC}$	-5		5	$\mu A$ A
	Output voltage high RxD under disturbances to fulfil functional state A <sup>[4]</sup>	$V_{OH\_RxD}$	$R_{load} = 2.7k\text{ to }V_{CC}$	$V_{CC}-1$			V C

Notes:

- [1] A = 100% serial test, B = Operating parameter, C = only used for data characterization (cpk), D = Value guaranteed by design
- [2] No watchdog reset; Watchdog trigger time on WDI = t.b.d.ms; Measurement of the average current of 10 watchdog periods.
- [3] The nominal  $V_{CC}$  voltage is measured at  $V_{SUP} = 12V$ . If the  $V_{CC}$  voltage is 100mV below its nominal value then the voltage drop is  $V_D = V_{SUP} - V_{CC}$
- [4] Functionality range of current limitation at silent mode is limited by reset threshold  $V_{RES}$ . Below them the IC change to normal mode.  
Validity for  $I_{VCC\_MAXsil}$  :  $V_{CCn}(\text{min}) \leq V_{CC} \leq V_{RES}$

## 1.2. AC Characteristics

$6V \leq V_S \leq 27V$ ,  $-40^\circ C \leq T_A \leq 125^\circ C$ , RTG connected to VCC, unless otherwise specified

**Table 4: AC Characteristics**

Parameter	Symbol	Condition	Min	Typ	Max	Unit	T <sup>[1]</sup>
<b>Reset parameter on NRES</b>							
16.01	Reset time	$t_{Res}$	$V_S = 14V$	2.5	4	5.5	ms A
16.02	Reset rising time	$t_{rr}$	$V_S = 14V$	3.0	6.5	12	$\mu s$ A
<b>Watchdog parameter on NRES (MLX80031, MLX80051)</b>							
17.01	Watchdog-Oscillator Period (on TM9)	$t_{WDOSC20}$	$RB_{WD} = 20k\Omega \pm 1\%$	6.87	8.09	9.30	$\mu s$ A
17.02		$t_{WDOSC60}$	$RB_{WD} = 51k\Omega \pm 1\%$	16.06	18.90	21.73	$\mu s$ A
17.03		$t_{WDOSC100}$	$RB_{WD} = 100k\Omega \pm 1\%$	30.58	35.98	41.37	$\mu s$ A

Parameter	Symbol	Condition	Min	Typ	Max	Unit	T <sup>[1]</sup>	
17.04		$t_{WDOSC150}$ $R_{BWD} = 150k\Omega \pm 1\%$	45.40	53.41	61.42	$\mu s$	A	
	Watchdog Close Window	$t_{CW}$ $t_{WDOSC}$		1053		cycles	D	
	Watchdog Open Window	$t_{OW}$ $t_{WDOSC}$		1105		cycles	D	
17.05	Watchdog Reset Low Time	$t_{WDres}$	3	4	5	ms	A	
	Watchdog Lead Window	$t_{LDT}$ $t_{WDOSC}$		7895		cycles	D	
17.06	Watchdog Safety Oscillator	$t_{WDSafety}$ $R_{BWD} \text{ gnd}$	30	50	75	$\mu s$	A	
<b>Wake-up and Mode Control</b>								
18.01	Remote Wake-up filter time	$t_{wu\_remote}$	30	70	150	$\mu s$	A	
18.02	Wake-up filter time on WAKE (only MLX80051,MLX80031)	$t_{wu\_WAKE}$	Sleep or Silent Mode, WAKE falling edge	10	50	$\mu s$	A	
18.03	Wake-up filter time on KL15 (only MLX80051,MLX80031)	$t_{wu\_KL15}$	Sleep or Silent Mode, KL15 rising edge	80	168	250	$\mu s$	A
18.04	Propagation delay from Normal Mode to Sleep Mode via EN	$t_{pd\_sleep}$	$V_{EN} = 0V$	5	15	20	$\mu s$	A
18.05	Propagation delay from Standby Mode to Normal Mode via EN	$t_{pd\_norm}$	$V_{EN} = 5V$	5	15	20	$\mu s$	A
18.06	Propagation delay from Silent Mode to Normal Mode via EN	$t_{pd\_sil\_n}$	$V_{EN} = 5V$	5	15	40	$\mu s$	A
18.07	Propagation delay: go to silent mode after EN=H/L <sup>[3]</sup>	$t_{pd\_sil}$	check falling edge on RBwd $V_{EN} = 0V$		20	$\mu s$	A	
	Setup time TxD to EN for low slew mode	$t_{set\_TxD\_EN}$	5			$\mu s$	B	
	Hold time TxD after EN for low slew mode	$t_{hold\_TxD\_EN}$	20			$\mu s$	B	
18.08	Debouncing time EN	$t_{deb\_EN}$	2	5	20	$\mu s$	A	
18.09	TxD dominant time out	$t_{TxD\_to}$	Normal Mode, $V_{TxD} = 0V$	27	60	ms	A	
18.10	Standby time out	$t_{sby\_to}$	Standby Mode, $V_{EN} = 0V$	150	500	ms	A	
<b>General LIN Parameter</b>								
19.01	Receiver propagation delay LIN -> RxD	$t_{dr\_RxD}$ $t_{df\_RxD}$	$C_{L(RxD)} = 50 \text{ pF}$		6	$\mu s$	A	
19.02	Symmetry prop. delay LIN->RxD	$t_{dsym\_RxD}$	$t_{dr\_RxD} - t_{df\_RxD}$	-2	2	$\mu s$	A	
19.03	Receiver debouncing time	$t_{deb\_LIN}$		1.5	2.8	4.0	$\mu s$	D

Parameter	Symbol	Condition	Min	Typ	Max	Unit	T <sup>[1]</sup>	
19.04	slew rate rising edge LIN	dV/dTrise	Normal Mode LIN-Load: 1k $\Omega$ / 1nF	1.0	1.5	2.5	V/ $\mu$ s	C
19.05	slew rate falling edge LIN	dV/dTfall		-2.5	-1.5	-1.0	V/ $\mu$ s	C
19.06	slew rate rising edge LIN	dV/dTrise	Low Slew Mode LIN-Load: 1k $\Omega$ / 1nF	0.3	0.8	1.3	V/ $\mu$ s	C
19.07	slew rate falling edge LIN	dV/dTfall		-1.3	-0.8	-0.3	V/ $\mu$ s	C
	Internal capacity	C <sub>LIN</sub>	Pulse at LIN via 10kOhm with 0/10 V; VS = open		25	35	pF	D
<b>LIN transceiver parameter according to LIN Physical Layer Spec. rev. 2.0, table 3.4 (20kbit/s)</b>								
Conditions: Normal slew mode; V <sub>S</sub> = 7.0V to 18V; LIN loads: 1k $\Omega$ /1nF; 660 $\Omega$ /6.8nF; 500 $\Omega$ /10nF TxD signal: t <sub>Bit</sub> = 50 $\mu$ s, t <sub>wH</sub> = T <sub>wL</sub> = t <sub>Bit</sub> ; t <sub>rise</sub> = t <sub>fall</sub> < 100ns								
	Minimal recessive bit time [2]	t <sub>rec(min)</sub>		40	50	58	$\mu$ s	
	Maximum recessive bit time [2]	t <sub>rec(max)</sub>		40	50	58	$\mu$ s	
20.01	Duty cycle 1	D <sub>1</sub>	D <sub>1</sub> = t <sub>rec(min)</sub> / (2*t <sub>Bit</sub> )	0.396				A
20.02	Duty cycle 2	D <sub>2</sub>	D <sub>2</sub> = t <sub>rec(max)</sub> / (2*t <sub>Bit</sub> )			0.581		A
<b>Transceiver parameter according to LIN Physical Layer Spec. rev. 2.0, table 3.4 (10.4kbit/s)</b>								
Conditions: Low slew mode; V <sub>S</sub> = 7.0V to 18V; LIN loads: 1k $\Omega$ /1nF; 660 $\Omega$ /6.8nF; 500 $\Omega$ /10nF TxD signal: t <sub>Bit</sub> = 96 $\mu$ s, t <sub>wH</sub> = T <sub>wL</sub> = t <sub>Bit</sub> ; t <sub>rise</sub> = t <sub>fall</sub> < 100ns								
	Minimal recessive bit time [2]	t <sub>rec(min)</sub>		80	96	113	$\mu$ s	
	Maximum recessive bit time [2]	t <sub>rec(max)</sub>		80	96	113	$\mu$ s	
21.01	Duty cycle 1	D <sub>3</sub>	D <sub>3</sub> = t <sub>rec(min)</sub> / (2*t <sub>Bit</sub> )	0.417				A
21.02	Duty cycle 2	D <sub>4</sub>	D <sub>4</sub> = t <sub>rec(max)</sub> / (2*t <sub>Bit</sub> )			0.590		A
<b>LIN transceiver parameter according to SAE J2602 (10.4kbit/s)</b>								
Conditions: Low slew mode; V <sub>S</sub> = 7.0V to 18V; LIN loads: 1k $\Omega$ /1nF; 660 $\Omega$ /6.8nF; 500 $\Omega$ /10nF TxD signal: t <sub>Bit</sub> = 96 $\mu$ s, t <sub>wH</sub> = T <sub>wL</sub> = t <sub>Bit</sub> ; t <sub>rise</sub> = t <sub>fall</sub> < 100ns								
22.01	Minimal recessive delay TxD -> LIN [2]	t <sub>x_rec_min</sub>				48	$\mu$ s	A
22.02	Maximum recessive delay TxD -> LIN [2]	t <sub>x_rec_max</sub>				48	$\mu$ s	A
22.03	Minimal dominant delay TxD -> LIN [2]	t <sub>x_dom_min</sub>				48	$\mu$ s	A
22.04	Maximum dominant delay TxD -> LIN [2]	t <sub>x_dom_max</sub>				48	$\mu$ s	A
22.05	Maximum rec. to dom. delay	T <sub>r_d_max</sub>	t <sub>x_rec_max</sub> - t <sub>x_dom_min</sub>			15.9	$\mu$ s	A
22.06	Maximum dom. to rec. delay	T <sub>d_r_max</sub>	t <sub>x_dom_max</sub> - t <sub>x_rec_min</sub>			17.2	$\mu$ s	A

[1] A = 100% serial test, B = Operating parameter, C = only used for data characterization (cpk),  
D = Value guaranteed by design

1.3. **Timing diagrams**

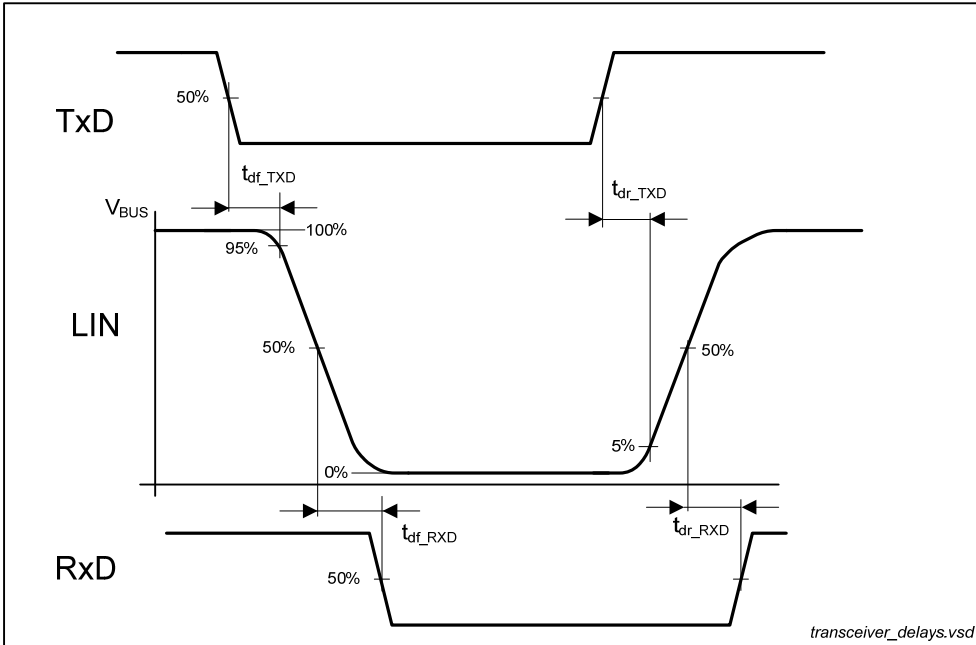

**Figure 1: LIN propagation delays**

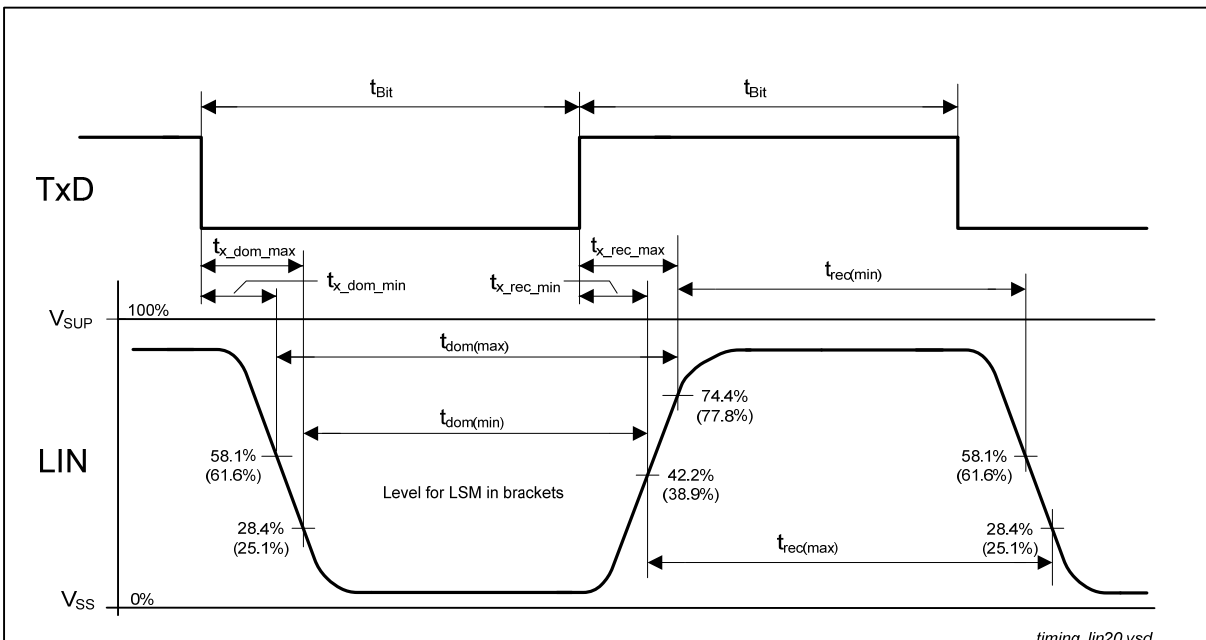

**Figure 2: LIN duty cycles**

## 2. Pin Configuration

### 2.1. MLX80030 and MLX80050 - SOIC8

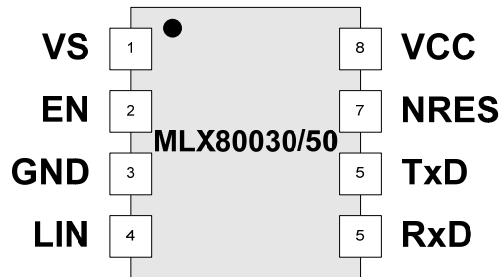

Table 5: MLX80050/30 pin list in SOIC8

Pin	Name	IO-Typ	Description
1	VS	P	Battery supply voltage
2	EN	I	Mode control pin, enables the normal operation mode when HIGH
3	GND	G	Ground
4	LIN	I/O	LIN bus transmitter/receiver pin, (low = dominant)
5	RxD	I/O	Received data from LIN bus, low in dominant state; internal pull-up resistor
6	TxD	I/O	Transmit data input (low = dominant)
7	NRES	O	Undervoltage reset output (open drain), low active
8	VCC	P	Voltage regulator output



## 2.2. MLX80031 and MLX80051 in QFN20

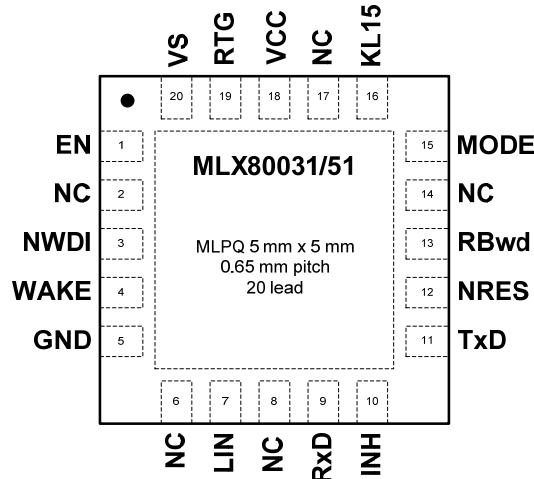

Table 6: MLX80051/31 pin list in QFN20

Pin	Name	IO-Typ	Description
1	EN	I	Mode control pin, enables the normal operation mode when HIGH
2	NC		not connected
3	NWDI	I	Watchdog trigger input; negative edge; pull-up
4	WAKE	I	High voltage input for local wake up, negative edge triggered
5	GND	G	Ground
6	NC		not connected
7	LIN	I/O	LIN bus transmitter/receiver pin, (low = dominant)
8	NC		not connected
9	RxD	I/O	Received data from LIN bus, low in dominant state; internal pull-up resistor
10	INH	O	High side switch; High voltage
11	TxD	I/O	Transmit data input (low = dominant)
12	NRES	O	Reset output (open drain), low active
13	RBwd	I/O	Bias resistor for watchdog oscillator
14	NC		not connected
15	MODE	I	Input to control window watchdog; internal pull-down resistor
16	KL15	I	High voltage input for local wake up, positive edge triggered
17	NC		not connected
18	VCC	I	Voltage regulator sense input
19	RTG	P	Voltage regulator output
20	VS	P	Battery supply voltage

### 3. Functional Description

The MLX8003x/5x consists of a low drop 3.3V/5V voltage regulator capable to drive 70mA and a LIN bus transceiver, which is a bi-directional bus interface for data transfer between LIN bus and the LIN protocol controller. Additionally integrated is a Window-Watchdog/RESET unit with a fixed power-on-reset delay of 4 ms and an adjustable watchdog time defined by an external bias resistor.

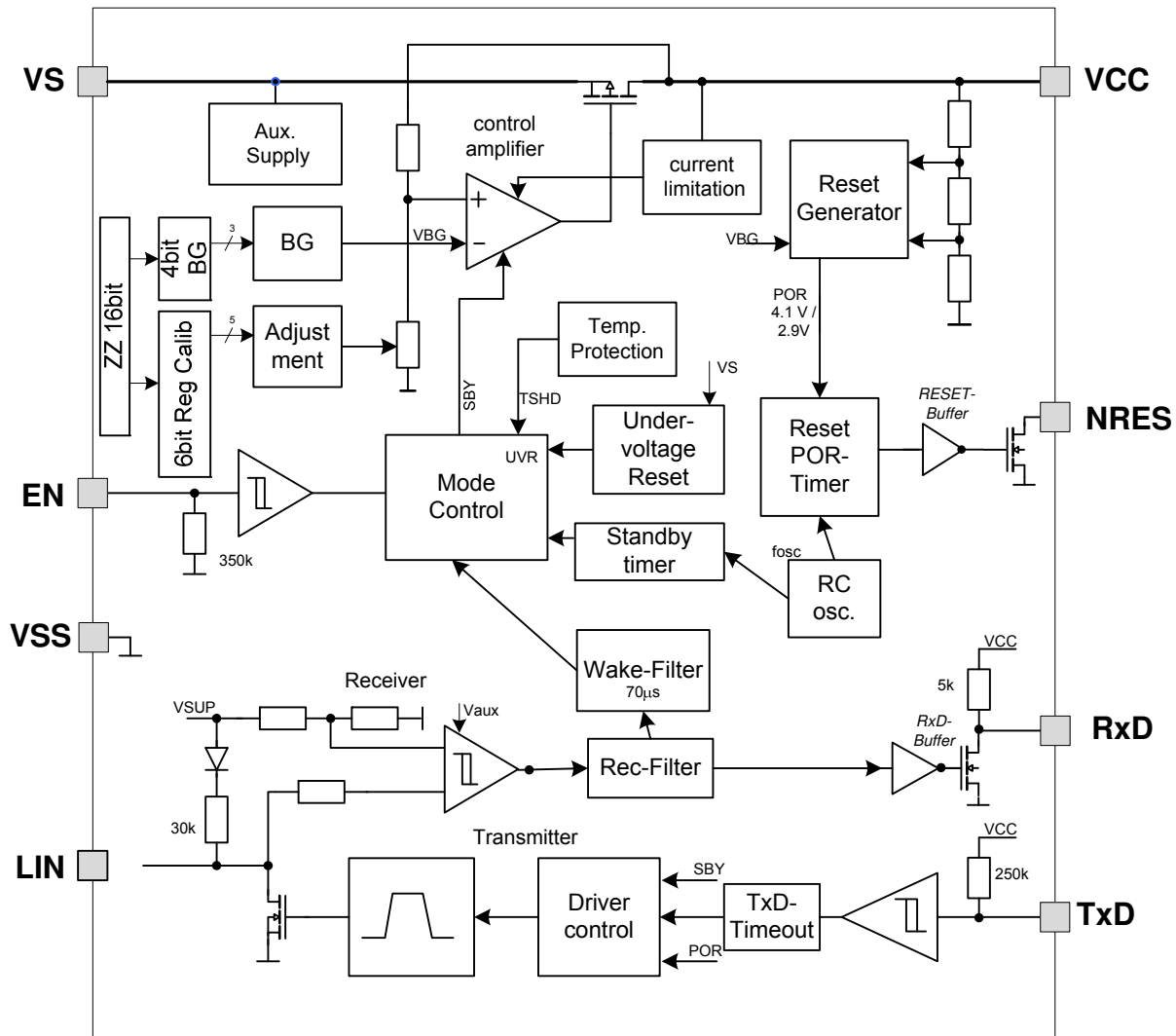
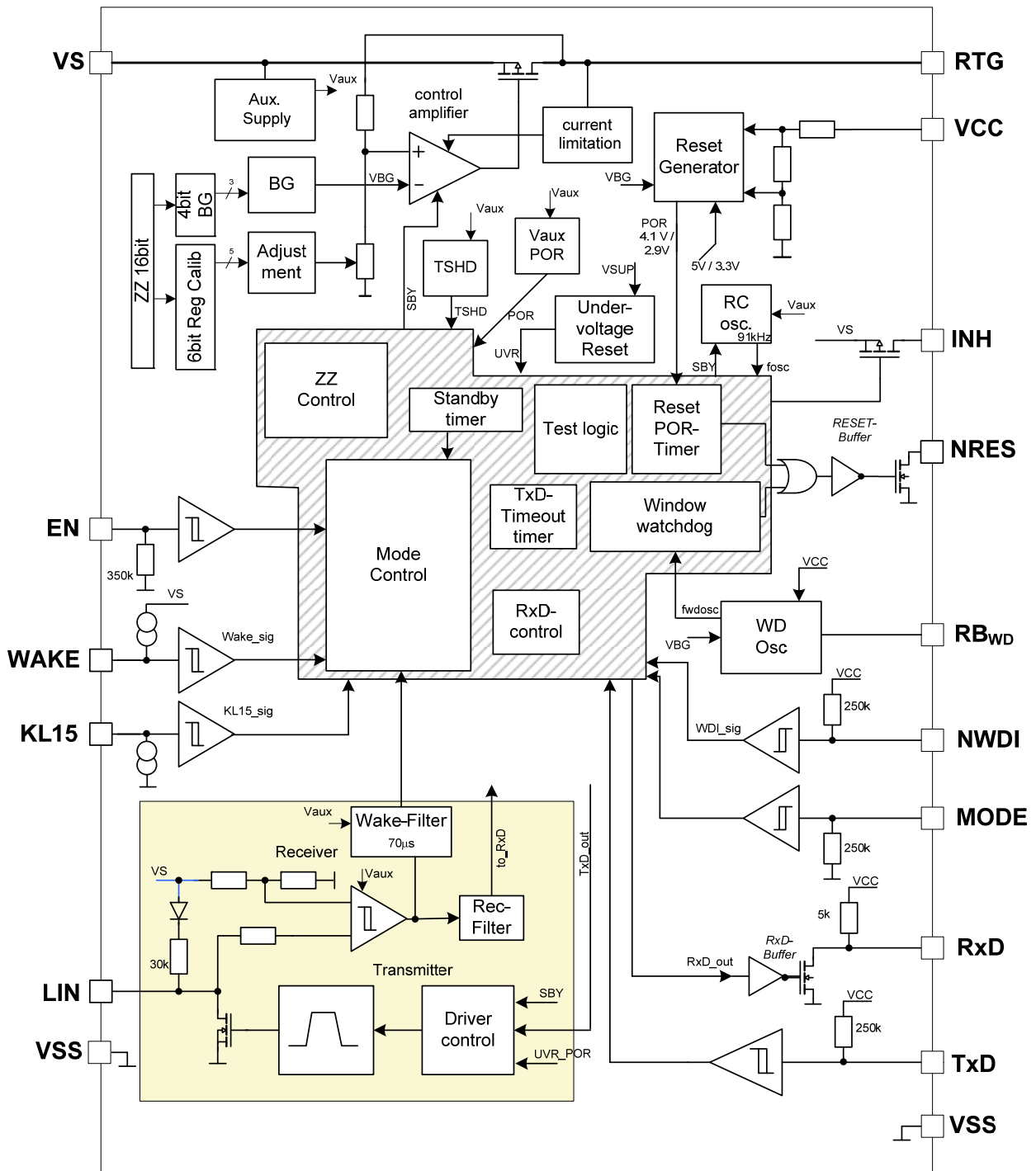

Figure 3: MLX80050/30 Block Diagram



**Figure 4: MLX80051/31 Block Diagram**

### 3.1. **Supply Pin VS**

VS is the operational voltage pin of MLX8005x/3x. The voltage range is  $V_S = 6$  to 18V. After switching on VS, the MLX8003x/5x starts at Standby Mode and the VCC voltage regulator ramps up. An undervoltage detection unit prevents an undefined operation for  $V_S < 4V$ .

#### **VS- Power-ON**

If VS is switched on, the MLX8003x/5x starts in Standby Mode. A combination of dynamic POR and under voltage reset circuitry generates a POR signal, which switches the MLX8003x/5x on. This power on behaviour is independent from the status of the EN-pin.

Power-on reset and under-voltage reset operate independent from each other, which secures the independence from the rise time of VS.

### 3.2. **EN input pin**

The ENable input is the mode control pin of MLX8003x/5x in combination with the TxD input.

The MLX8003x/5x is switched into the Sleep Mode with a falling edge and into normal mode with a rising edge at the EN pin. The state machine goes to Normal Mode after  $t_{Res}$  (see also Table 4: AC Characteristics). The Normal Mode will be kept as long as EN remains high.

The Normal Mode can be entered from Standby Mode, when the pin EN is driven HIGH. To prevent unwanted mode transitions, the EN input contains a debounce filter as specified ( $t_{EN\_deb}$ ).

The pin EN contains a weak pull down resistor. The input thresholds are compatible to 3.3V and 5V supply systems.

#### MLX80031/51:

Additionally the positive edge on pin EN results in an immediate reset of the active low interrupt on pin RxD as well as the wake-up source recognition flag on pin TxD.

### 3.3. **Ground pin GND**

This is the reference pin of the IC. The absence of GND connection will not influence or disturb the communication between other LIN bus nodes.

### 3.4. **LIN**

This bidirectional pin consists of a low side driver in the output path and a high-voltage comparator in the input path. Furthermore is integrated a LIN pull-up resistor between LIN and VS pin. Low side driver consists of a current limitation.

### 3.5. **Receiver Output RxD**

The pin RxD is a buffered open drain output. Output signals can be shifted by the external pull up resistor to 3.3V and 5V supply systems.

### 3.6. **Transmit Input TxD**

The transmit data stream of the LIN protocol controller applied to the pin TxD is converted into the LIN bus signal with slew rate control in order to minimize electromagnetic emissions.

The pin TxD contains a weak pull up resistor. The input thresholds are compatible to 3.3V and 5V supply systems. To enable the transmit path, the TxD pin has to be driven recessive (HIGH) after or during the normal mode has been entered.

#### **3.6.1. TxD dominant time-out feature**

With the first dominant level on pin TxD after the transmit path has been enabled, the dominant time-out counter is started. In case of a faulty blocked permanent dominant level on pin TxD the transmit path will be disabled after the specified time  $t_{TxD\_to}$ . The time-out counter is reset by the first negative edge on pin TxD.

### 3.7. **Output NRES**

The NRES pin outputs the reset state as well as the watchdog condition in MLX80031 and MLX80051.

### 3.8. **Voltage regulator pins VCC and RTG**

The MLX80030/50 has an integrated low drop linear regulator with a p-channel-MOSFET as driving transistor. This regulator outputs a voltage of 5V  $\pm$ 2% (MLX80050/51) or 3.3V  $\pm$ 2% (MLX80030/31) with a load current of max. 70mA. The current limitation unit limits the output current for short circuits or overload to 130mA by decreasing the VCC voltage. This way the power dissipation is held constant at a maximum value.

The voltage regulator has two pins, output pin RTG and sense input pin VCC. For MLX80030/50 both, RTG and VCC, are commonly bonded to pin VCC on the package.

Devices MLX80031/51 has both pins bonded and provides the possibility to use an external npn transistor to boost the maximum load current. In this case the basis of the npn transistor has to be connected to the RTG pin and the emitter to the VCC pin. In case of using the internal voltage regulator, both pins have to be connected to each other.

### 3.9. **INH Output (only MLX80031/51)**

INH switches to high (VS connected to INH) in case of Standby or Normal Mode. INH is switched off at Silent and Sleep Mode. The pin will be used for switch on an external power supply or for switch off the external 1k master resistor in master node applications.

### 3.10. **WAKE Input (only MLX80031/51)**

High voltage input pin for local wake-up functionality. With a falling edge on WAKE the IC wakes-up from Silent Mode or Sleep Mode to Standby Mode.

The pin WAKE provides a weak pull up current source towards Vs which provides a HIGH level on the pin in case of open circuit failures or if no local wake-up feature is required. In such applications it is recommended to connect the pin WAKE directly to pin Vs in order to prevent influences due to EMI.

### 3.11. **KL15 Input (only MLX80031/51)**

High voltage input pin for local wake-up functionality. With a rising edge on KL15 the IC wakes-up from Silent Mode or Sleep Mode to Standby Mode.

The pin KL15 provides a weak current sink towards GND which provides a LOW level on the pin in case of open circuit failures or if no local wake-up feature is required. In such applications it is recommended to connect the pin KL15 directly to GND in order to prevent influences due to EMI. KL15 is typically connected to the ignition terminal and generates a local wake-up at start of ignition.

### 3.12. **Watchdog Trigger Input NWDI (only MLX80031/51)**

This input is used to trigger the integrated window watchdog in MLX80031/51. Every falling edge on NWDI in watchdog open window is used to reset the watchdog timer. An internal pull up resistor of 250k secures a stable high condition if this pin is open. The NWDI input is a low voltage CMOS input.

### 3.13. **Watchdog Oscillator Resistor RB<sub>WD</sub> (only MLX80031/51)**

A resistor between RB<sub>WD</sub> and GND defines the window watchdog times as trigger time and reset time.

### 3.14. **Mode Input MODE (only MLX80031/51)**

Special pin for to disable the window watchdog function. For normal watchdog operation connect the MODE pin to GND directly or via external resistor. With MODE pin on 3.3V/5V the window watchdog is switched off.

### 4. Operational Modes

The MLX8003x/5x provides four main operating modes “Standby”, “Normal”, “Silent” and “Sleep”. The main modes are fixed states defined by basic actions (VS start, EN or wake-up).

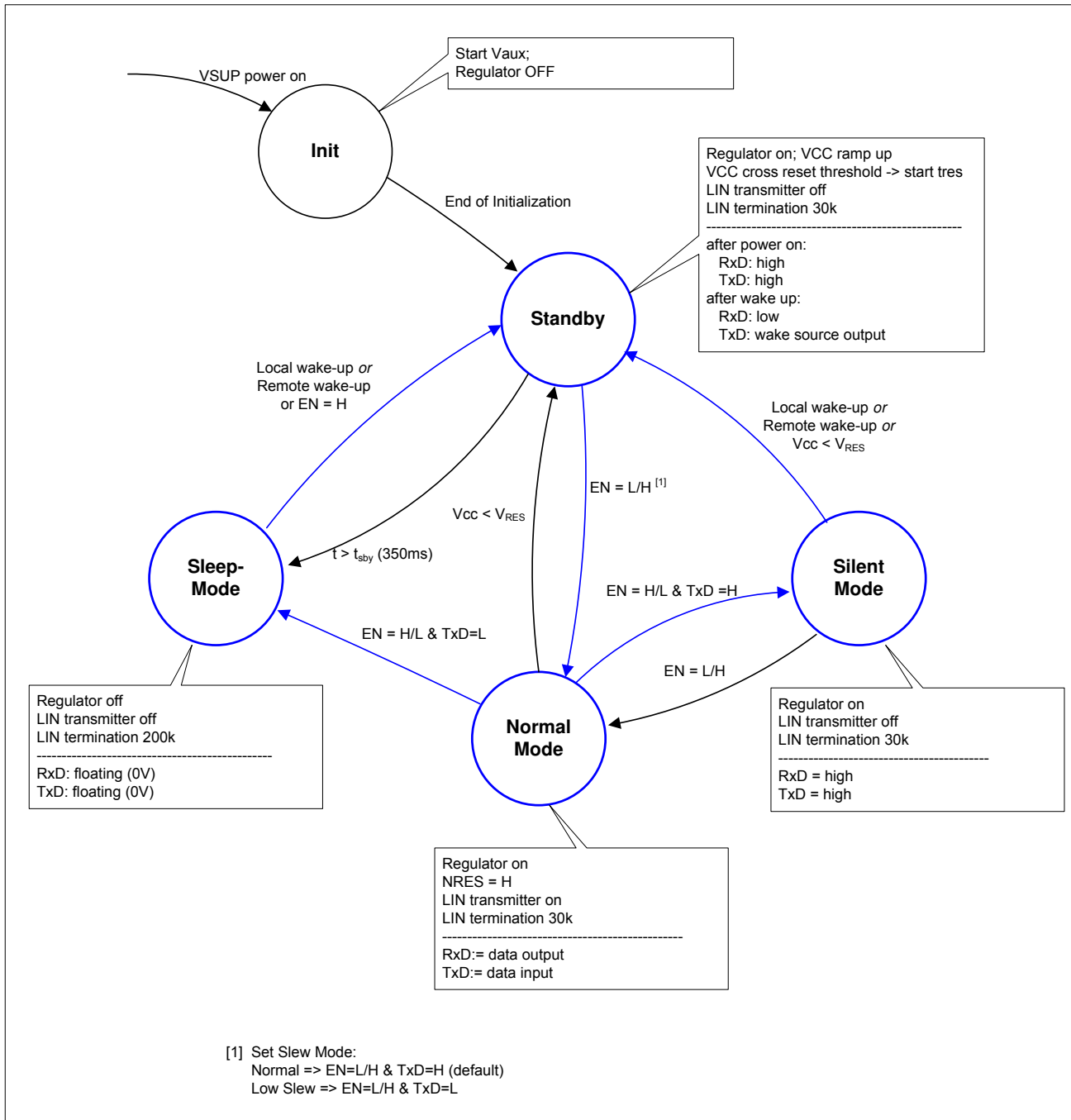

Figure 5: MLX8005x3x state diagram of modes of operation

### 4.1. Modes Overview

**Table 7: MLX80050/30 Operation Modes**

Mode	VCC	TxD	RxD	LIN	remarks
Standby	3.3V/5V	high	high	recessive	entered after power on or wake up
Normal	3.3V/5V	input for transmit data stream	output for LIN data stream	follows TxD	[1]
Silent	3.3V/5V	high	high	recessive	high = 3.3V/5V
Sleep	0	floating	floating	recessive	remote wake up to enter Standby Mode, EN = H to go to Normal Mode

[1] Normal mode will be entered from Standby Mode by a low -> high transition on pin EN and from Sleep Mode by EN = H after startup of the regulator. When recessive level (high) on pin TxD is present the transmit path will be enabled

**Table 8: MLX80051/31 Operation Modes**

Mode	VCC	TxD	RxD	LIN	INH	Watchdog	remarks
Standby	3.3V/5V	High/ active low <sup>[1]</sup>	high/ active low <sup>[2]</sup>	recessive	ON	ON	entered after power on or wake up
Normal	3.3V/5V	input for transmit data stream	output for LIN data stream	follows TxD	ON	ON	[3] [4] [5]
Silent	3.3V/5V	high	high	recessive	OFF	OFF	
Sleep	0	floating	floating	recessive	OFF	OFF	Local or remote wake up to enter Standby Mode, EN = H to go to Normal Mode

[1] Indicates the wake up flag in case of local wake up

[2] After power on RxD is going high via pull-up to Vcc. If any wake up(local or remote) occurs it will be indicated by active low

[3] Active low interrupt at pin RxD will be removed when entering normal mode

[4] Wake up source flag at pin TxD will be removed when entering normal mode

[5] Normal mode will be entered from Standby Mode by a low -> high transition on pin EN and from Sleep Mode by EN = H after startup of the regulator. When recessive level (high) on pin TxD is present the transmit path will be enabled

### 4.2. *Initialisation and Standby mode*

When the battery supply voltage  $V_S$  exceeds the specified threshold  $V_{SUVR\_OFF}$ , the MLX8003x/5x automatically enters the Standby Mode. Following internal procedure is running:

**First:**

- Start of internal supply  $V_{aux}$  and POR of  $V_{aux}$
- Start of internal RC oscillator

**Second** and parallel after POR:

- Start of voltage regulator

The output voltage  $V_{CC}$  ramps up to nominal value. The pin RxD is floating and the integrated slave pull up resistor with decoupling diode pulls the pin LIN. The transmitter as well as the receiver is disabled.

If there occurs no mode change to Normal Mode via an EN LOW to HIGH transition within the time stated (typically 350ms), the IC enters the most power saving Sleep Mode.

Furthermore the standby mode will be entered after a valid local or remote wake up event, when the MLX8003x/5x is in Sleep or Silent mode. The entering of the standby mode after wake up will be indicated by an active LOW interrupt on pin RxD.

### 4.3. *Normal Mode*

This mode is the base mode. The bus transceiver is able to send with a max baud rate of 20kbit/s.

The whole MLX8003x/5x is active. The incoming bus traffic is detected by the receiver and transferred via the RxD output pin to the microcontroller.

To exit the Normal Mode with on of the following condition:

1. High-to-low edge on EN pin with TxD = H -> switch to Silent Mode
2. High-to-low edge on EN pin with TxD = L -> switch to Sleep Mode
3. Undervoltage monitor on VCC detects a low voltage reset condition ( $V_{CC} < V_{RES}$ ) -> switch back to stand-by mode.

#### *Low Slew Mode*

The first rising edge on EN after power-on defines the slew rate of the device. With TxD = High at this point works the MLX8003x/5x with normal slew rate (default state). TxD = Low activates the Low Slew Mode, as long as  $V_S > V_{SUVR\_OFF}$ .

In this mode the slew rate is switched from the normal value of typ.  $1.6V/\mu s$  to a low value of typ.  $0.8V/\mu s$ . This mode is optimized to send with a maximum baud rate of 10.4kbit/s (acc. to SAE J2602). Because of this reduction of the slew rate the EME behaviour is improved especially in the frequency range of 100 kHz to 10MHz.



### 4.4. Silent Mode

The Silent Mode is a special mode for application with active Sleep Mode on LIN, but the connected MCU still needs to be supplied with VCC.

With a falling edge on EN input in combination with TxD=high switches the MLX8003x/5x from Normal Mode to the Silent Mode with reduced internal current consumption.

In Silent Mode the voltage regulator is on with a 2% tolerance. The transmitter is disabled and the pin RxD is disconnected from the receive path and is floating. The slave termination resistor (LIN pull up resistor with decoupling diode between pins LIN and VS) is disconnected; only a weak current source is applied to the LIN bus. Value is typical -75uA, limits -20...-100uA.

To exit the silent mode with on of the following condition:

1. Low-to-high edge on the EN pin -> switch back to normal mode
2. Remote wake up (all versions) or local wake up request (MLX80031/51 only) -> switch to standby mode
3. Undervoltage monitor on VCC detects a low voltage reset condition ( $VCC < V_{RES}$ ) -> switch back to stand-by mode.

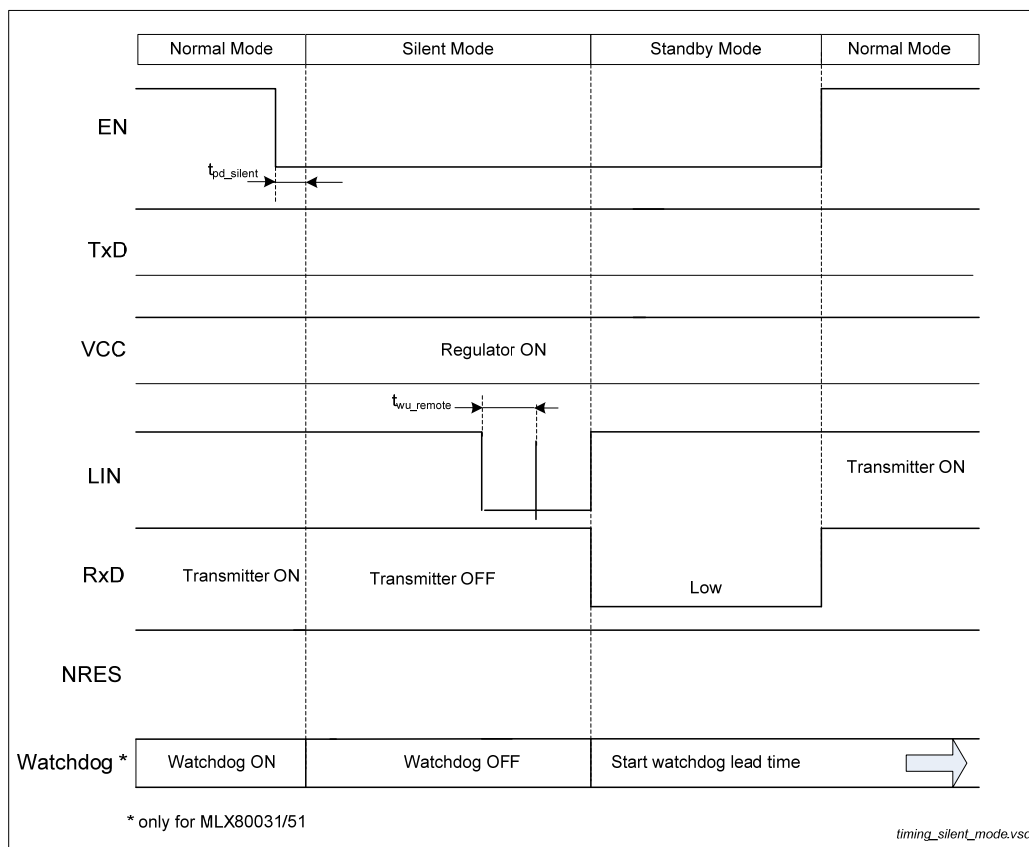

**Figure 6: LIN wake-up from Silent Mode**

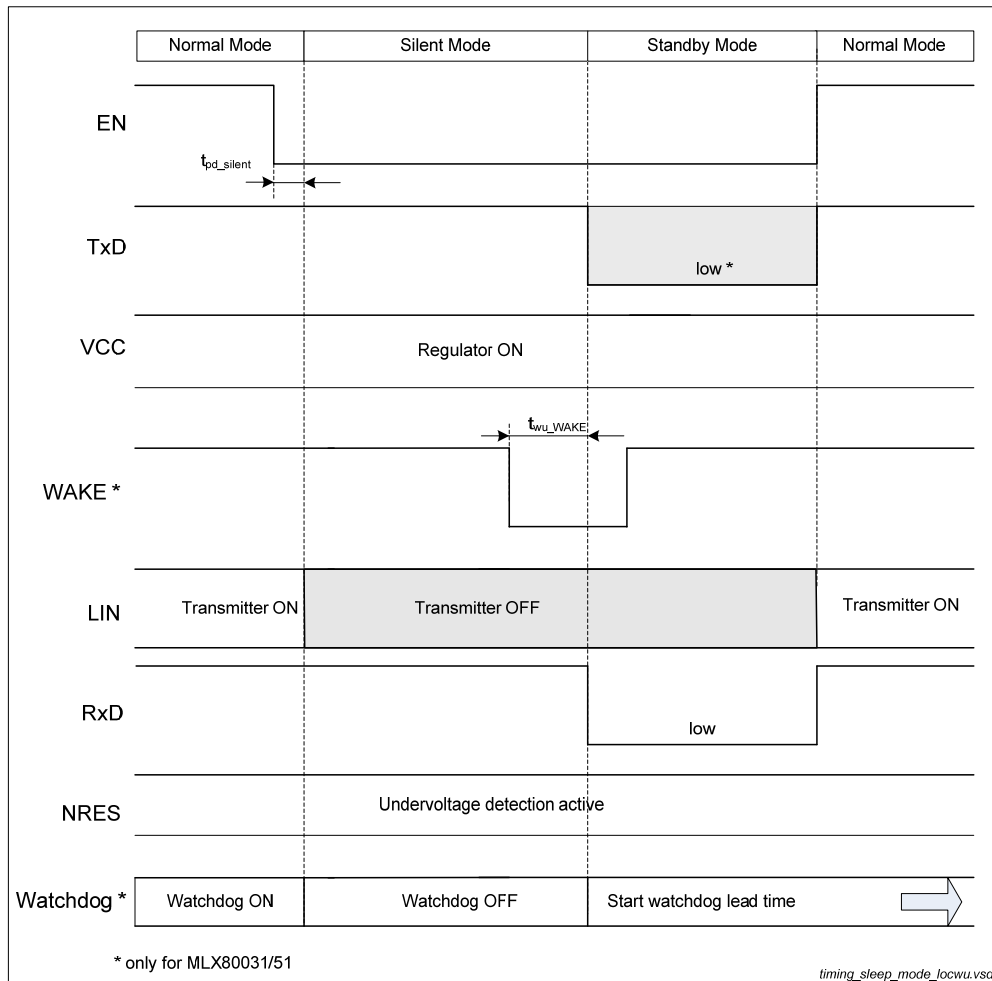

**Figure 7 Local Wake-up from Silent Mode via WAKE**

### 4.5. Sleep Mode

The most power saving mode of the MLX8003x/5x is the Sleep Mode. The MLX8003x/5x offers two procedures to enter the sleep mode:

- The mode is selected from normal mode with a falling edge on EN in combination with TxD = L.
- If the MLX8003x/5x is in Standby Mode after power-on or wake-up, a sleep counter is started and switches the transceiver into Sleep Mode after the specified time (typ. 350ms) even when the microcontroller of the ECU will not confirm the normal operation by setting the EN pin to logic HIGH. This new feature allows faulty blocked LIN nodes to reach always the most power saving mode.

Being in Sleep Mode the voltage regulator switched off in order to minimize the current consumption of the complete LIN node. The transmitter is disabled and the pin RxD is disconnected from the receive path and is low (follows VCC). The slave termination resistor (LIN pull up resistor with decoupling diode between pins LIN and VS) is disconnected, only a weak current source is applied to the LIN bus (see chapter 8 fail-safe features)

To exit the Sleep Mode with one of the following condition(s):

1. Remote (all versions) or local wake up request (MLX80031/51 only) -> Switch to Standby Mode