



Chipsmall Limited consists of a professional team with an average of over 10 year of expertise in the distribution of electronic components. Based in Hongkong, we have already established firm and mutual-benefit business relationships with customers from,Europe,America and south Asia,supplying obsolete and hard-to-find components to meet their specific needs.

With the principle of “Quality Parts,Customers Priority,Honest Operation,and Considerate Service”,our business mainly focus on the distribution of electronic components. Line cards we deal with include Microchip,ALPS,ROHM,Xilinx,Pulse,ON,Everlight and Freescale. Main products comprise IC,Modules,Potentiometer,IC Socket,Relay,Connector.Our parts cover such applications as commercial,industrial, and automotives areas.

We are looking forward to setting up business relationship with you and hope to provide you with the best service and solution. Let us make a better world for our industry!



Contact us

Tel: +86-755-8981 8866 Fax: +86-755-8427 6832

Email & Skype: info@chipsmall.com Web: www.chipsmall.com

Address: A1208, Overseas Decoration Building, #122 Zhenhua RD., Futian, Shenzhen, China



Features and Benefits

- Absolute Rotary Position Sensor IC
- Simple & Robust Magnetic Design
- Tria[⊗]is[®] Hall Technology
- Programmable Angular Range up to 360 Degrees
- Programmable Linear Transfer Characteristic
- Selectable Analog (Ratiometric), PWM, Serial Protocol
- 12 bit Angular Resolution - 10 bit Angular Thermal Accuracy
- 40 bit ID Number
- Single Die – SO8 Package RoHS Compliant
- Dual Die (Full Redundant) – TSSOP16 Package RoHS Compliant

Tria[⊗]is[®]

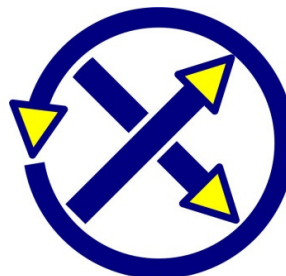

Applications

- Absolute Rotary Position Sensor
- Steering Wheel Position Sensor
- Pedal Position Sensor
- Motor-shaft Position Sensor
- Throttle Position Sensor
- Float-Level Sensor
- Ride Height Position Sensor
- Non-Contacting Potentiometer

Ordering Code

Product Code	Temperature Code	Package Code	Option Code	Packing Form Code
MLX90316	S	DC	BCG-000	RE
MLX90316	S	DC	BCG-000	TU
MLX90316	E	DC	BCG-000	RE
MLX90316	E	DC	BCG-000	TU
MLX90316	K	DC	BCG-000	RE
MLX90316	K	DC	BCG-000	TU
MLX90316	L	DC	BCG-000	RE
MLX90316	L	DC	BCG-000	TU
MLX90316	E	GO	BCG-000	RE
MLX90316	E	GO	BCG-000	TU
MLX90316	K	GO	BCG-000	RE
MLX90316	K	GO	BCG-000	TU
MLX90316	L	GO	BCG-000	RE
MLX90316	L	GO	BCG-000	TU
MLX90316	K	DC	BCG-200	RE
MLX90316	K	DC	BCG-200	TU
MLX90316	K	GO	BCG-200	RE
MLX90316	K	GO	BCG-200	TU
MLX90316	K	DC	BCG-300	RE
MLX90316	K	DC	BCG-300	TU
MLX90316	K	GO	BCG-300	RE
MLX90316	K	GO	BCG-300	TU
MLX90316	E	DC	BDG-100	RE
MLX90316	E	DC	BDG-100	TU

MLX90316	K	DC	BDG-100	RE
MLX90316	K	DC	BDG-100	TU
MLX90316	L	DC	BDG-100	TU
MLX90316	L	DC	BDG-100	RE
MLX90316	E	GO	BDG-100	TU
MLX90316	E	GO	BDG-100	RE
MLX90316	K	GO	BDG-100	TU
MLX90316	K	GO	BDG-100	RE
MLX90316	L	GO	BDG-100	TU
MLX90316	L	GO	BDG-100	RE
MLX90316	L	GO	BDG-102	TU
MLX90316	L	GO	BDG-102	RE
MLX90316	L	DC	BDG-102	TU
MLX90316	L	DC	BDG-102	RE
MLX90316	L	DC	BCS-000	TU
MLX90316	L	DC	BCS-000	RE

Legend:

Temperature Code:	L for Temperature Range -40°C to 150°C E for Temperature Range -40°C to 85°C K for Temperature Range -40°C to 125°C S for Temperature Range -20°C to 85°C
Package Code:	DC for SOIC150 GO for TSSOP173
Option Code:	AAA-xxx: die version xxx-000: standard xxx-100: SPI xxx-102: SPI75AGC, see section 14.4.2 xxx-200: PPA (Pre-programmed Analog) xxx-300: PPD (Pre-programmed Digital)
Packing Form:	RE for Reel, TU for Tube
Ordering example:	MLX90316KDC-BCG-000-TU

1. Functional Diagram

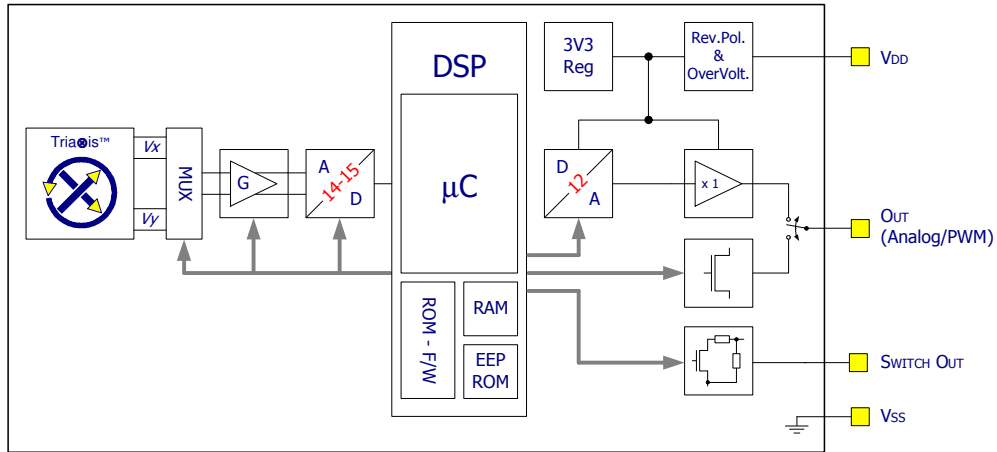

Figure 1 - Block Diagram (Analog & PWM)

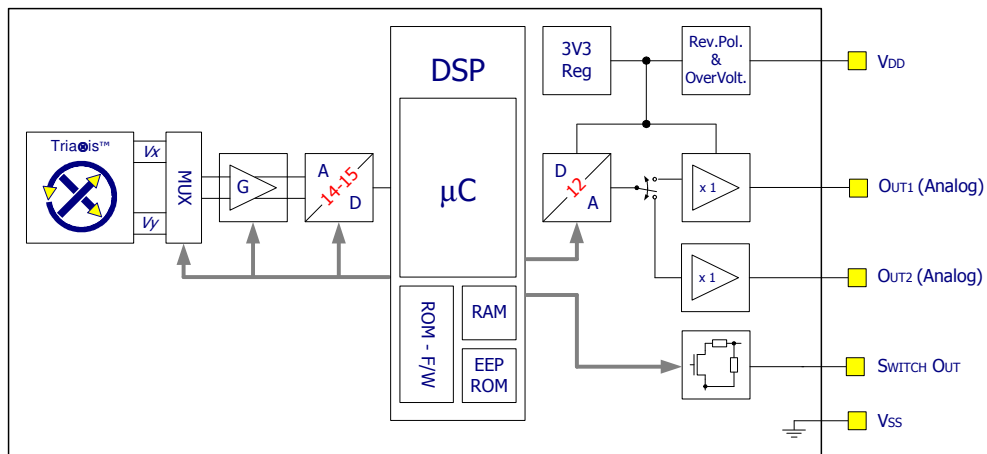

Figure 2 - Block Diagram Analog (MLX90316BCS)

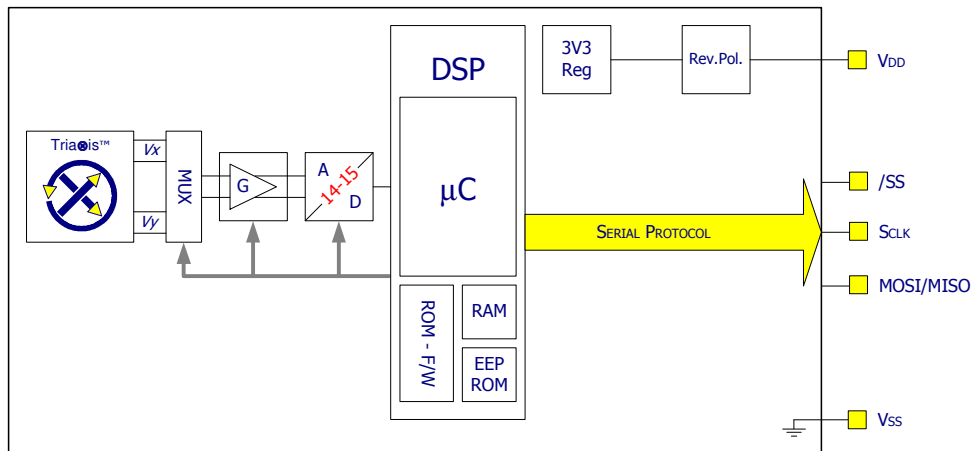

Figure 3 - Block Diagram (Serial Protocol)

2. Description

The MLX90316 is a monolithic sensor IC featuring the Tria^{is} Hall technology. Conventional planar Hall technology is only sensitive to the flux density applied orthogonally to the IC surface. The Tria^{is} Hall sensor is also sensitive to the flux density applied parallel to the IC surface. This is obtained through an Integrated Magneto-Concentrator (IMC[®]) which is deposited on the CMOS die (as an additional back-end step).

The MLX90316 is only sensitive to the flux density coplanar with the IC surface. This allows the MLX90316 with the correct magnetic circuit to decode the absolute rotary (angular) position from 0 to 360 Degrees. It enables the design of novel generation of non-contacting rotary position sensors that are frequently required for both automotive and industrial applications.

In combination with the appropriate signal processing, the magnetic flux density of a small magnet (diametral magnetization) rotating above the IC can be measured in a non-contacting way (Figure 4). The angular information is computed from both vectorial components of the flux density (i.e. B_x and B_y). MLX90316 produces an output signal proportional to the decoded angle. The output is selectable between Analog, PWM and Serial Protocol.

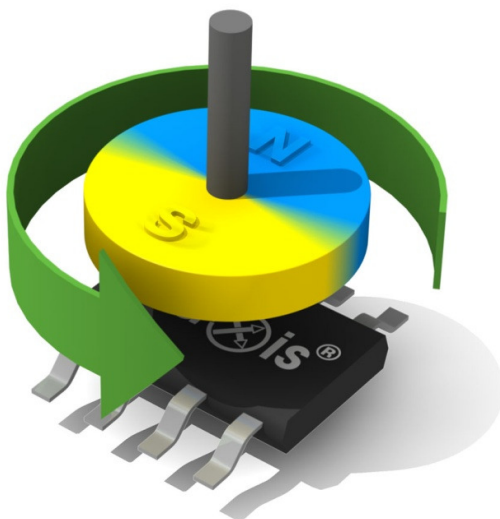

Figure 4 - Typical application of MLX90316

TABLE of CONTENTS

FEATURES AND BENEFITS	1
APPLICATIONS.....	1
ORDERING CODE.....	1
1. FUNCTIONAL DIAGRAM.....	3
2. DESCRIPTION.....	5
3. GLOSSARY OF TERMS – ABBREVIATIONS – ACRONYMS	8
4. PINOUT	8
5. ABSOLUTE MAXIMUM RATINGS	9
6. DETAILED DESCRIPTION.....	9
7. MLX90316 ELECTRICAL SPECIFICATION.....	11
8. MLX90316 ISOLATION SPECIFICATION	13
9. MLX90316 TIMING SPECIFICATION	13
10. MLX90316 ACCURACY SPECIFICATION	14
11. MLX90316 MAGNETIC SPECIFICATION	15
12. MLX90316 CPU & MEMORY SPECIFICATION	15
13. MLX90316 END-USER PROGRAMMABLE ITEMS	16
14. DESCRIPTION OF END-USER PROGRAMMABLE ITEMS.....	17
14.1. OUTPUT MODE.....	17
14.1.1. <i>Analog Output Mode</i>	17
14.1.2. <i>PWM Output Mode</i>	17
14.1.3. <i>Serial Protocol Output Mode</i>	19
14.1.4. <i>Switch Out</i>	19
14.2. OUTPUT TRANSFER CHARACTERISTIC.....	19
14.2.1. <i>CLOCKWISE Parameter</i>	19
14.2.2. <i>Discontinuity Point (or Zero Degree Point)</i>	19
14.2.3. <i>LNR Parameters</i>	20
14.2.4. <i>CLAMPING Parameters</i>	20
14.2.5. <i>DEADZONE Parameter</i>	21
14.2.6. <i>MLX90316 xDC- BCS ONLY</i>	21
14.3. IDENTIFICATION	21
14.4. SENSOR FRONT-END	22
14.4.1. <i>HIGHSPEED Parameter</i>	22
14.4.2. <i>ARGC, AUTO_RG, RoughGain and FORCECRA75 Parameters</i>	22
14.4.3. <i>RGThresL, RGThresH Parameters</i>	23
14.5. FILTER	23
14.5.1. <i>Hysteresis Filter</i>	23
14.5.2. <i>FIR Filters</i>	23
14.5.3. <i>IIR Filters</i>	26
14.6. PROGRAMMABLE DIAGNOSTIC SETTINGS	27
14.6.1. <i>RESONFAULT Parameter</i>	26
14.6.2. <i>EEHAMHOLE Parameter</i>	26
14.7. LOCK.....	26
14.7.1. <i>MLXLOCK Parameter</i>	27
14.7.2. <i>LOCK Parameter</i>	27

15. MLX90316 SELF DIAGNOSTIC.....	28
16. SERIAL PROTOCOL.....	30
16.1. INTRODUCTION	30
16.2. SERIAL PROTOCOL MODE	30
16.3. MOSI (MASTER OUT SLAVE IN)	30
16.4. MISO (MASTER IN SLAVE OUT)	30
16.5. SS (SLAVE SELECT)	30
16.6. MASTER START-UP	30
16.7. SLAVE START-UP.....	30
16.8. TIMING.....	31
16.9. SLAVE RESET	32
16.10. FRAME LAYER	32
16.10.1. <i>Command Device Mechanism</i>	32
16.10.2. <i>Data Frame Structure</i>	32
16.10.3. <i>Timing</i>	32
16.10.4. <i>Data Structure</i>	33
16.10.5. <i>Angle Calculation</i>	33
16.10.6. <i>Error Handling</i>	33
17. RECOMMENDED APPLICATION DIAGRAMS	34
17.1. ANALOG OUTPUT WIRING WITH THE MLX90316 IN SOIC PACKAGE.....	34
17.2. ANALOG OUTPUT WIRING WITH THE MLX90316 IN TSSOP PACKAGE.....	35
17.3. PWM LOW SIDE OUTPUT WIRING	35
17.4. SERIAL PROTOCOL	36
17.4.1. <i>SPI Version – Single Die</i>	36
17.4.2. <i>SPI Version – Dual Die</i>	37
17.4.3. <i>Non SPI Version (Standard Version)</i>	38
18. STANDARD INFORMATION REGARDING MANUFACTURABILITY OF MELEXIS PRODUCTS WITH DIFFERENT SOLDERING PROCESSES	39
19. ESD PRECAUTIONS.....	39
20. PACKAGE INFORMATION.....	40
20.1. SOIC8 - PACKAGE DIMENSIONS	40
20.2. SOIC8 - PINOUT AND MARKING	40
20.3. SOIC8 - IMC POSITIONNING.....	41
20.4. TSSOP16 - PACKAGE DIMENSIONS	42
20.5. TSSOP16 - PINOUT AND MARKING	43
20.6. TSSOP16 - IMC POSITIONNING.....	43
21.DISCLAIMER.....	45

3. Glossary of Terms – Abbreviations – Acronyms

- Gauss (G), Tesla (T): Units for the magnetic flux density – 1 mT = 10 G
- TC: **T**emperature **C**oefficient (in ppm/Deg.C.)
- NC: **N**ot **C**onected
- PWM: **P**ulse **W**idth **M**odulation
- %DC: **D**uty **C**ycle of the output signal i.e. $T_{ON} / (T_{ON} + T_{OFF})$
- ADC: **A**nalog-to-**D**igital **C**onverter
- DAC: **D**igital-to-**A**nalog **C**onverter
- LSB: **L**east **S**ignificant **B**it
- MSB: **M**ost **S**ignificant **B**it
- DNL: **D**ifferential **N**on-**L**inearity
- INL: **I**ntegral **N**on-**L**inearity
- RISC: **R**educed **I**nstruction **S**et **C**omputer
- ASP: **A**nalog **S**ignal **P**rocessing
- DSP: **D**igital **S**ignal **P**rocessing
- ATAN: trigonometric function: arctangent (or inverse tangent)
- IMC: **I**ntegrated **M**agneto-**C**oncentrator (IMC®)
- CoRDiC: **C**oordinate **R**otation **D**igital **C**omputer (i.e. iterative rectangular-to-polar transform)
- EMC: **E**lectro-**M**agnetic **C**ompatibility

4. Pinout

Pin #	SOIC-8		TSSOP-16	
	Analog / PWM	Serial Protocol	Analog / PWM	Serial Protocol
1	VDD	VDD	VDIG ₁	VDIG ₁
2	Test 0	Test 0	VSS ₁ (Ground ₁)	VSS ₁ (Ground ₁)
3	Switch Out	/SS	VDD ₁	VDD ₁
4	Not Used / Out 2 ⁽¹⁾	SCLK	Test 0 ₁	Test 0 ₁
5	Out	MOSI / MISO	Switch Out ₂	/SS ₂
6	Test 1	Test 1	Not Used ₂	SCLK ₂
7	VDIG	VDIG	Out ₂	MOSI ₂ / MISO ₂
8	VSS (Ground)	VSS (Ground)	Test 1 ₂	Test 1 ₂
9			VDIG ₂	VDIG ₂
10			VSS ₂ (Ground ₂)	VSS ₂ (Ground ₂)
11			VDD ₂	VDD ₂
12			Test 0 ₂	Test 0 ₂
13			Switch Out ₁	/SS ₁
14			Not Used ₁	SCLK ₁
15			Out ₁	MOSI ₁ / MISO ₁
16			Test 1 ₁	Test 1 ₁

For optimal EMC behavior, it is recommended to connect the unused pins (Not Used and Test) to the Ground (see section 17).

¹ MLX90316xDC-BCS includes a programmable second output

5. Absolute Maximum Ratings

Parameter	Value
Supply Voltage, VDD (overvoltage)	+ 20 V
Reverse Voltage Protection	- 10 V
Positive Output Voltage – Standard Version (Analog or PWM)	+ 10 V + 14 V (200 s max – T _A = + 25°C)
Positive Output Voltage – SPI Version	VDD + 0.3V
Positive Output Voltage (Switch Out)	+ 10 V + 14 V (200 s max – T _A = + 25°C)
Output Current (I _{OUT})	± 30 mA
Reverse Output Voltage	- 0.3 V
Reverse Output Current	- 50 mA
Operating Ambient Temperature Range, T _A	- 40°C ... + 150°C
Storage Temperature Range, T _S	- 40°C ... + 150°C
Magnetic Flux Density	± 700 mT

Exceeding the absolute maximum ratings may cause permanent damage. Exposure to absolute-maximum-rated conditions for extended periods may affect device reliability.

6. Detailed Description

As described on the block diagram (Figure 1, Figure 2 and Figure 3), the magnetic flux density parallel to the IC surface (i.e. B_{||}) is sensed through the Tria[⊗]is[⊗] sensor front-end. This front-end consists into two orthogonal pairs (for each of the two directions parallel with the IC surface i.e. X and Y) of conventional planar Hall plates (blue area on Figure 5) and an Integrated Magneto-Concentrator (IMC[⊗] yellow disk on Figure 5).

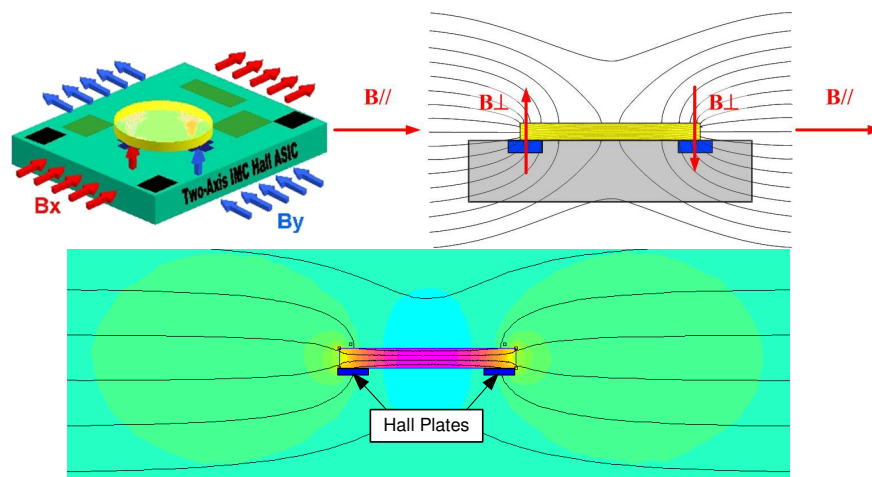

Figure 5 - Tria[⊗]is[⊗] sensor front-end (4 Hall plates + IMC[⊗] disk)

Both components of the applied flux density $B_{//}$ are measured individually i.e. $B_{X//}$ and $B_{Y//}$. Two orthogonal components (respectively $B_{X\perp}$ and $B_{Y\perp}$) proportional to the parallel components (respectively $B_{X//}$ and $B_{Y//}$) are induced through the IMC and can be measured by both respective pairs of conventional planar Hall plates as those are sensitive to the flux density applied orthogonally to them and the IC surface.

While a magnet (diametrically magnetized) rotates above the IC as described on Figure 4, the sensing stage provides two differential signals in quadrature (sine and cosine – Figure 6 and Figure 7)

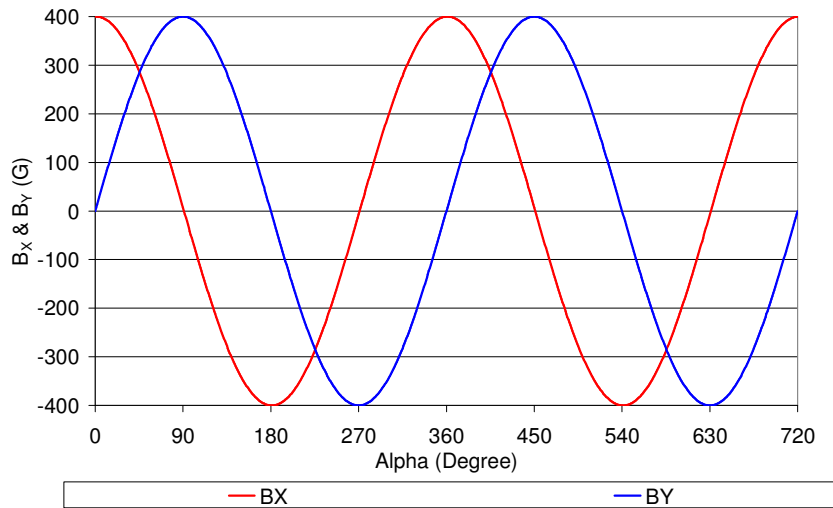

Figure 6 – Magnetic Flux Density – $B_x \propto \cos(\alpha)$ & $B_y \propto \sin(\alpha)$

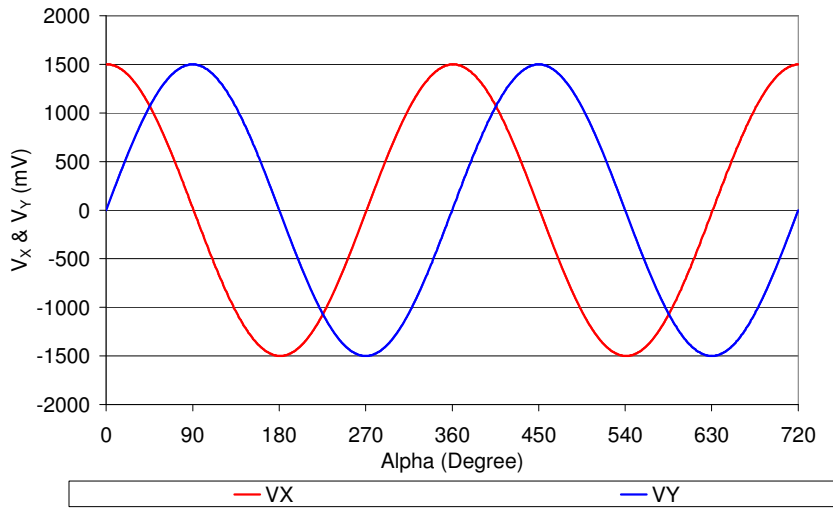

Figure 7 – Triaxis® sensor front-end – Output signals – $V_x \propto B_x \propto \cos(\alpha)$ & $V_y \propto B_y \propto \sin(\alpha)$

Those Hall signals are processed through a fully differential analog chain featuring the classic offset cancellation technique (Hall plate quadrature spinning and chopper-stabilized amplifier).

The conditioned analog signals are converted through an ADC (configurable – 14 or 15 bits) and provided to a DSP block for further processing. The DSP stage is based on a 16 bit RISC micro-controller whose primary function is the extraction of the angular position from the two raw signals (after so-called front-end compensation steps) through the following operation:

$$\alpha = ATAN\left(\frac{V_Y}{V_X}\right)$$

The DSP functionality is governed by the micro-code (firmware – F/W) of the micro-controller which is stored into the ROM (mask programmable). In addition to the “ATAN” function, the F/W controls the whole analog chain, the output transfer characteristic, the output protocol, the programming/calibration and also the self-diagnostic modes.

In the MLX90316, the “ATAN” function is computed via a look-up table (i.e. it is not obtained through a CoRDic algorithm).

Due to the fact that the “ATAN” operation is performed on the ratio “ V_Y/V_X ”, the angular information is intrinsically self-compensated vs. flux density variations (due to airgap change, thermal or ageing effects) affecting both signals. This feature allows therefore an improved thermal accuracy vs. rotary position sensor based on conventional linear Hall sensors.

In addition to the improved thermal accuracy, the realized rotary position sensor is capable of measuring a complete revolution (360 Degrees) and the linearity performances are excellent taking into account typical manufacturing tolerances (e.g. relative placement between the Hall IC and the magnet).

Once the angular information is computed (over 360 degrees), it is further conditioned (mapped) vs. the target transfer characteristic and it is provided at the output(s) as:

- an analog output level through a 12 bit DAC followed by a buffer
- a digital PWM signal with 12 bit depth (programmable frequency 100 Hz ... 1 kHz)
- a digital Serial Protocol (SP – 14 bits computed angular information available)

For instance, the analog output can be programmed for offset, gain and clamping to meet any rotary position sensor output transfer characteristic:

$$\begin{aligned} V_{out}(\alpha) &= \text{ClampLo} && \text{for } \alpha \leq \alpha_{min} \\ V_{out}(\alpha) &= V_{offset} + \text{Gain} \times \alpha && \text{for } \alpha_{min} \leq \alpha \leq \alpha_{max} \\ V_{out}(\alpha) &= \text{ClampHi} && \text{for } \alpha \geq \alpha_{max} \end{aligned}$$

where V_{offset} , Gain, ClampLo and ClampHi are the main adjustable parameters for the end-user.

The linear part of the transfer curve can be adjusted through either a 2 point or a 3 point calibration depending on the linearity requirement.

A digital output is also available and used as a programmable angular switch.

The calibration parameters are stored in EEPROM featuring a Hamming Error Correction Coding (ECC).

The programming steps do not require any dedicated pins. The operation is done using the supply and output nodes of the IC. The programming of the MLX90316 is handled at both engineering lab and production line levels by the Melexis Programming Unit PTC-04 with the dedicated MLX90316 daughterboard and software tools (DLL – User Interface).

7. MLX90316 Electrical Specification

DC Operating Parameters at $V_{DD} = 5V$ (unless otherwise specified) and for T_A as specified by the Temperature suffix (S, E, K or L).

Parameter	Symbol	Test Conditions	Min	Typ	Max	Units
Nominal Supply Voltage	V_{DD}		4.5	5	5.5	V
Supply Current ⁽²⁾	I_{dd}	Slow mode ⁽³⁾		8.5	11	mA
		Fast mode ⁽³⁾		13.5	16	mA
POR Level	$V_{DD} \text{ POR}$	Supply Under Voltage	2	2.7	3	V
Output Current	I_{out}	Analog Output mode	-8		8	mA
		PWM Output mode	-20		20	mA
Output Short Circuit Current	I_{short}	$V_{out} = 0V$		12	15	mA
		$V_{out} = 5V$		12	15	mA
		$V_{out} = 14V$ ($T_A = 25^\circ C$)		24	45	mA
Output Load	R_L	Pull-down to Ground	1	10	∞ ⁽⁵⁾	k Ω
		Pull-up to 5V ⁽⁴⁾	1	10	∞ ⁽⁵⁾	k Ω
Analog Saturation Output Level	V_{sat_lo}	Pull-up load $R_L \geq 10k\Omega$			3	%VDD
	V_{sat_hi}	Pull-down load $R_L \geq 10k\Omega$	96			%VDD
Digital Saturation Output Level	V_{satD_lo}	Pull-up Low Side $R_L \geq 10k\Omega$ Push-Pull ($I_{OUT} = -20mA$)			1.5	%VDD
	V_{satD_hi}	Push-Pull ($I_{OUT} = 20mA$)	97			%VDD
Active Diagnostic Output Level	$Diag_lo$	Pull-down load $R_L \geq 10k\Omega$ Pull-up load $R_L \geq 10k\Omega$			1 1.5	%VDD
	$Diag_hi$	Pull-down load $R_L \geq 10k\Omega$ Pull-up load $R_L \geq 10k\Omega$	97 98			%VDD
Passive Diagnostic Output Level (Broken Track Diagnostic) ⁽⁶⁾	BV_{ssPD}	Broken V_{SS} ⁽⁷⁾ & Pull-down load $R_L \leq 10k\Omega$			4 ⁽⁶⁾	%VDD
	BV_{ssPU}	Broken V_{SS} ⁽⁷⁾ & Pull-up load $R_L \geq 1k\Omega$	99	100		%VDD
	BV_{DDPD}	Broken V_{DD} ⁽⁷⁾ & Pull-down load $R_L \geq 1k\Omega$		0	1	%VDD
	BV_{DDPU}	Broken V_{DD} & Pull-up load to 5V	No Broken Track diagnostic			%VDD
MLX 90316 Electrical Specification continues...						
...MLX 90316 Electrical Specification						

² For the dual version, the supply current is multiplied by 2

³ See section 14.4.1 for details concerning Slow and Fast mode

⁴ Applicable for output in Analog and PWM (Open-Drain) modes

⁵ $R_L < \infty$ for output in PWM mode

⁶ For detailed information, see also section 15

⁷ Not Valid for the SPI Version

Clamped Output Level	Clamp_lo	Programmable	0	100	%VDD ⁽⁸⁾
	Clamp_hi	Programmable	0	100	%VDD ⁽⁸⁾
Switch Out ⁽⁹⁾	Sw_lo	Pull-up Load 1.5k to 5V	0.55	1.1	V
	Sw_hi	Pull-up Load 1.5k to 5V	3.65	4.35	V

As an illustration of the previous table, the MLX90316 fits the typical classification of the output span described on the Figure 8.

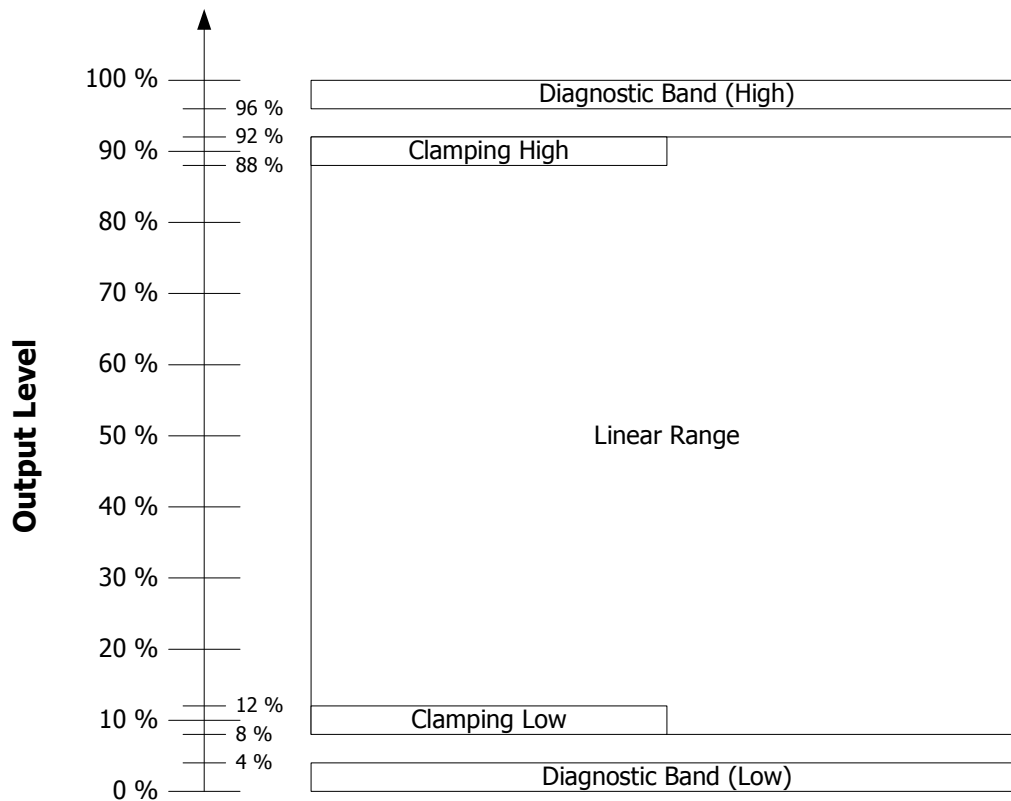

Figure 8 - Output Span Classification

⁸ Clamping levels need to be considered vs the saturation of the output stage (see Vsat_lo and Vsat_hi)

⁹ See section 14.1.4 for the application diagram

8. MLX90316 Isolation Specification

DC Operating Parameters at $V_{DD} = 5V$ (unless otherwise specified) and for T_A as specified by the Temperature suffix (S, E, K or L). Only valid for the package code GO i.e. dual die version.

Parameter	Symbol	Test Conditions	Min	Typ	Max	Units
Isolation Resistance		Between 2 dies	4			M Ω

9. MLX90316 Timing Specification

DC Operating Parameters at $V_{DD} = 5V$ (unless otherwise specified) and for T_A as specified by the Temperature suffix (S, E, K or L).

Parameter	Symbol	Test Conditions	Min	Typ	Max	Units
Main Clock Frequency	Ck	Slow mode ⁽¹⁰⁾		7		MHz
		Fast mode ⁽¹⁰⁾		20		MHz
Sampling Rate		Slow mode ⁽¹¹⁾		600		μ s
		Fast mode ⁽¹¹⁾		200		μ s
Step Response Time	Ts	Slow mode ⁽¹⁰⁾ , Filter=5 ⁽¹¹⁾			4	ms
		Fast mode ⁽¹⁰⁾ , Filter=0 ⁽¹¹⁾		400	600	μ s
Watchdog	Wd	See Section 15			5	ms
Start-up Cycle	Tsu	Slow and Fast mode ⁽¹⁰⁾			15	ms
Analog Output Slew Rate		$C_{OUT} = 42$ nF		200		V/ms
		$C_{OUT} = 100$ nF		100		
PWM Frequency	F _{PWM}	PWM Output Enabled	100		1000	Hz
Digital Output Rise Time		Mode 5 – 10nF, R _L = 10 k Ω		120		μ s
		Mode 7 – 10nF, R _L = 10 k Ω		2.2		μ s
Digital Output Fall Time		Mode 5 – 10nF, R _L = 10 k Ω		1.8		μ s
		Mode 7 – 10nF, R _L = 10 k Ω		1.9		μ s

¹⁰ See section 14.4.1 for details concerning Slow and Fast mode

¹¹ See section 14.5 for details concerning Filter parameter

10. MLX90316 Accuracy Specification

DC Operating Parameters at VDD = 5V (unless otherwise specified) and for T_A as specified by the Temperature suffix (S, E, K or L).

Parameter	Symbol	Test Conditions	Min	Typ	Max	Units
ADC Resolution on the raw signals sine and cosine	R _{ADC}	Slow Mode ⁽¹²⁾		15		bits
		Fast Mode ⁽¹²⁾		14		bits
Thermal Offset Drift #1 ⁽¹³⁾		Thermal Offset Drift at the DSP input (excl. DAC and output stage)				
		Temperature suffix S, E and K	-60		+60	LSB ₁₅
		Temperature suffix L	-90		+90	LSB ₁₅
Thermal Offset Drift #2 (to be considered only for the analog output mode)		Thermal Offset Drift of the DAC and Output Stage				
		Temperature suffix S, E and K	-0.3		+0.3	%VDD
		Temperature suffix L	-0.4		+0.4	%VDD
Thermal Drift of Sensitivity Mismatch ⁽¹⁴⁾		Temperature suffix S, E and K	-0.3		+0.3	%
		Temperature suffix L	-0.5		+0.5	%
Intrinsic Linearity Error ⁽¹⁵⁾	Le	T _A = 25°C	-1		1	Deg
Analog Output Resolution	R _{DAC}	12 bits DAC (Theoretical – Noise free)		0.025		%VDD/LSB
		INL	-4		+4	LSB
		DNL	-2		+2	LSB
Output stage Noise		Clamped Output		0.05		%VDD
Noise pk-pk ⁽¹⁶⁾		RG = 9, Slow mode, Filter=5		0.03	0.06	Deg
		RG = 9, Fast mode, Filter=0		0.1	0.2	Deg
Ratiometry Error			-0.1	0	0.1	%VDD
PWM Output Resolution	R _{PWM}	12 bits (Theoretical – Jitter free)		0.025		%DC/LSB
PWM Jitter ⁽¹⁷⁾	J _{PWM}	RG = 6, F _{PWM} = 250 Hz – 800Hz			0.2	%DC
Serial Protocol Output Resolution	R _{SP}	14 bits – 360 Deg. Mapping(Theoretical – Jitter free)		0.022		Deg/LSB

¹² 15 bits corresponds to 14 bits + sign and 14 bits corresponds to 13 bits + sign. After angular calculation, this corresponds to 0.005Deg/LSB₁₅ in Low Speed Mode and 0.01Deg/LSB₁₄ in High Speed.

¹³ For instance, Thermal Offset Drift #1 equal ± 60 LSB₁₅ yields to max. ± 0.3 Deg. angular error for the computed angular information (output of the DSP). See Front End Application Note for more details. This is only valid if automatic gain is set (See Section 14.4.2)

¹⁴ For instance, Thermal Drift of Sensitivity Mismatch equal $\pm 0.4\%$ yields to max. ± 0.1 Deg. angular error for the computed angular information (output of the DSP). See Front End Application Note for more details.

¹⁵ The Intrinsic Linearity Error refers to the IC itself (offset, sensitivity mismatch, orthogonality) taking into account an ideal rotating field. Once associated to a practical magnetic construction and the associated mechanical and magnetic tolerances, the output linearity error increases. However, it can be improved with the multi point end-user calibration that is available on the MLX90316.

¹⁶ The application diagram used is described in the recommended wiring. For detailed information, refer to section Filter in application mode (Section 14.5).

¹⁷ Jitter is defined by $\pm 3\sigma$ for 1000 successive acquisitions and the slope of the transfer curve is 100%DC/360 Deg.

11. MLX90316 Magnetic Specification

DC Operating Parameters at $V_{DD} = 5V$ (unless otherwise specified) and for T_A as specified by the Temperature suffix (S, E, K or L).

Parameter	Symbol	Test Conditions	Min	Typ	Max	Units
Magnetic Flux Density	B		20	50	70 ⁽¹⁸⁾	mT
Magnet Temperature Coefficient	TCm		-2400		0	ppm/°C

12. MLX90316 CPU & Memory Specification

The DSP is based on a 16 bit RISC μ Controller. This CPU provides 5 Mips while running at 20 MHz.

Parameter	Symbol	Test Conditions	Min	Typ	Max	Units
ROM				10		kB
RAM				256		B
EEPROM				128		B

¹⁸ Above 70 mT, the IMC starts saturating yielding to an increase of the linearity error.

13. MLX90316 End-User Programmable Items

Parameter	Comments	Default Values				
		STANDARD	SPI / SPI75AGC	PPA	PPD	# bit
Output Mode	Define the output stage mode	4	N/A	4	7	3
	MLX90316BCS	2	N/A	2	N/A	3
PWMPOL1	PWM Polarity	0	N/A	N/A	1	1
PWMT	PWM Frequency	1000h	N/A	N/A	1kHz	16
CLOCKWISE		0	0	0	1	1
DP	Discontinuity Point	0h	0h	0h	0h	15
LNR_S0	Initial Slope	0h	N/A	N/A	N/A	16
LNR_A_X	AX Coordinate	8000h	0	0	0	16
LNR_A_Y	AY Coordinate	0h	0%	10%	10%	16
LNR_A_S	AS Coordinate	0h	100%/360d	80%/360d	80%/360d	16
LNR_B_X	BX Coordinate	FFFFh	FFFFh	FFFFh	FFFFh	16
LNR_B_Y	BY Coordinate	0h	FFFFh	FFFFh	FFFFh	16
LNR_B_S	BS Coordinate	0h	N/A	N/A	N/A	16
LNR_C_X	CX Coordinate	FFFFh	FFFFh	FFFFh	FFFFh	16
LNR_C_Y	CY Coordinate	FFFFh	FFFFh	FFFFh	FFFFh	16
LNR_C_S	CS Coordinate	0h	N/A	N/A	N/A	16
CLAMP_HIGH	Clamping High	8%	0%	10%	10%	16
CLAMP_LOW	Clamping Low	8%	100%	90%	90%	16
KD	Switch Out	FFFFh	FFFFh	FFFFh	FFFFh	16
	MLX90316BCS	0	N/A	FFFFh	N/A	16
KDHYST	Hysteresis on the Switch Out	N/A	N/A	N/A	N/A	8
DEADZONE		0	0	0	0	8
FHYST		4	0	0	0	8
	MLX90316BCS	0	N/A	0	N/A	8
MLXID1 / MLXID2 / MLXID3		MLX	MLX	MLX	MLX	16
CUSTID1		1	1	1	1	8
CUSTID2 ⁽²⁰⁾		6 ⁽¹⁹⁾	19 / 36	16	20	16
CUSTID3		MLX	MLX	MLX	MLX	16
FREE2		0	0	0	0	8
	MLX90316BCS	0	N/A	2Ah	N/A	16
FILTER		5	0	2	5	16
FILTER A1 ⁽²⁰⁾	Filter coefficient A1 for FILTER=6	6600h	N/A	N/A	N/A	16
FILTER A2 ⁽²⁰⁾	Filter coefficient A2 for FILTER=6	2A00h	N/A	N/A	N/A	16
ARGC	Auto Gain at Start Up	0	1	1	1	1
	MLX90316BCS	0	N/A	1	N/A	1
HIGHSPEED		0	1	0	1	1
End-User Programmable Items continues...						

¹⁹ For MLX90316SDC-BCG-STANDARD, the CUSTOMERID2 parameter might differ from the given value (28d instead of 6d)

²⁰ Not available in MLX90316xDC-BCS

... End-User Programmable Items						
FSWAP		1	1	0	1	1
FORCECRA75	Radius Adjustment to 75%	0	0 / 1	0	0	1
AUTO_RG	Automatic Rough Gain Selection	0	1	1	1	1
RoughGain		9	0	3	0	8
	MLX90316BCS	6	N/A	3	N/A	8
RGThresL		0	0	0	0	4
RGThresH		15	15	15	15	4
EEHAMHOLE		3131h	0	0	0	16
RESONFAULT		0	1	1	1	2
MLXLOCK		0	1	1	1	1
LOCK		0	1	1	1	1
	MLX90316BCS	0	N/A	0	N/A	1
Parameter for MLX90316xDC-BCS only						
OUT2EN		1	N/A	1	N/A	1
OUT2 SLOPE RATIO	Was CUSTOMERID2	N/A	N/A	-1	N/A	8
OUT2 OFFSET		MLX	N/A	100%	N/A	8
CLAMP_LOW OUT2		8%	N/A	10%	N/A	16
CLAMP_HIGH OUT2		8%	N/A	90%	N/A	16

14. Description of End-User Programmable Items

14.1. Output Mode

The MLX90316 output type is defined by the Output Mode parameter.

Parameter	Value	Description
Analog Output Mode	2, 4	Analog Rail-to-Rail
PWM Output Mode	5	Low Side (NMOS)
	7	Push-Pull
Serial	N/A	Low Side (NMOS)

14.1.1. Analog Output Mode

The Analog Output Mode is a rail-to-rail and ratiometric output with a push-pull output stage configuration allows the use of a pull-up or pull-down resistor.

14.1.2. PWM Output Mode

If one of the PWM Output modes is selected, the output signal is a digital signal with Pulse Width Modulation (PWM).

In mode 5, the output stage is an open drain NMOS transistor (low side), to be used with a pull-up resistor to VDD.

In mode 7, the output stage is a push-pull stage for which Melexis recommends the use of a pull-up resistor to VDD.

The PWM polarity is selected by the PWMPOL1 parameter:

- PWMPOL1 = 0 for a low level at 100%
- PWMPOL1 = 1 for a high level at 100%

The PWM frequency is selected by the PWMT parameter.

PWM Frequency Code (based on typical main clock frequency)				
Oscillator Mode	Pulse-Width Modulation Frequency (Hz)			
	100	200	500	1000
Low Speed	~35000	~17500	~7000	~3500
High Speed	-	~50000	~20000	~10000

For instance, in Low Speed Mode, set PWMT=7000 (decimal) to set the PWM frequency around 500Hz⁽²¹⁾.

14.1.3. Serial Protocol Output Mode

The MLX90316 features a digital Serial Protocol mode. The MLX90316 is considered as a Slave node. See the dedicated Serial Protocol section for a full description (Section 16).

14.1.4. Switch Out

Parameter	Value	Unit
KD	0...359.9999	deg
KDHYST	0 ... 1.4	deg

The switch is activated (Sw_lo) when the digital angle is greater than the value stored in the KD parameter. This angle refers to the internal angular reference linked to the parameter DP and not to the absolute physical 0° angle.

The KDHYST defines the hysteresis amplitude around the Switch point. The switch is actually activated if the digital angle is greater than KD+KDHYST. It is deactivated if the digital angle is less than KD-KDHYST.

The mandatory application diagram to use this feature is depicted in the Figure 9. See section 7 for the electrical characteristic.

If the Switch feature is not used in the application, the output pin needs to be connected to the ground.

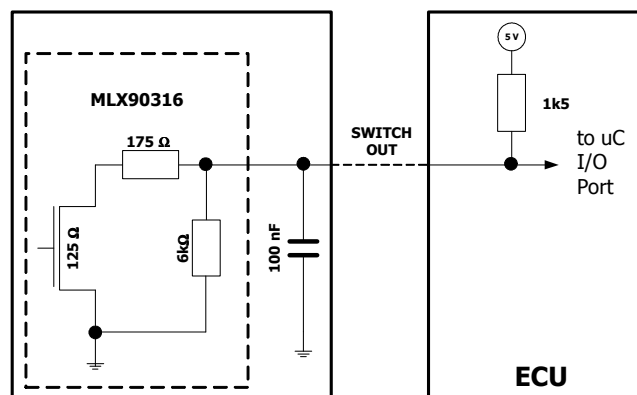

Figure 9 – Application Diagram for the Switch Out

²¹ In order to compensate the lot to lot variation of the main clock frequency (Ck), Melexis strongly recommends trimming the PWM frequency during EOL programming (see the PTC-04 documentation).

14.2. Output Transfer Characteristic

Parameter	Value	Unit
CLOCKWISE	0 → CCW 1 → CW	
DP	0 ... 359.9999	deg
LNR_A_X LNR_B_X LNR_C_X	0 ... 359.9999	deg
LNR_A_Y LNR_B_Y LNR_C_Y	0 ... 100	%
LNR_S0 LNR_A_S LNR_B_S	0 ... 17	%/deg
LNR_C_S	-17 ... 0 ... 17	%/deg
CLAMP_LOW	0 ... 100	%
CLAMP_HIGH	0 ... 100	%
DEADZONE	0 ... 359.9999	deg
MLX90316 xDC – BCS only		
OUT2 SLOPE RATIO	-8 ... 0 ... 8	-
OUT2 OFFSET	-400 ... 400	%
CLAMP_LOW OUT2	0 ... 100	%
CLAMP_HIGH OUT2	0 ... 100	%

14.2.1. CLOCKWISE Parameter

The CLOCKWISE parameter defines the magnet rotation direction.

- CCW is defined by the 1-4-5-8 pin order direction for the SOIC8 package and 1-8-9-16 pin order direction for the TSSOP16 package.
- CW is defined by the reverse direction: 8-5-4-1 pin order direction for the SOIC8 and 16-9-8-1 pin order direction for the TSSOP16 package.

Refer to the drawing in the IMC positioning sections (Section 20.3 and 20.6).

14.2.2. Discontinuity Point (or Zero Degree Point)

The Discontinuity Point defines the 0° point on the circle. The discontinuity point places the origin at any location of the trigonometric circle. The DP is used as reference for all the angular measurements.

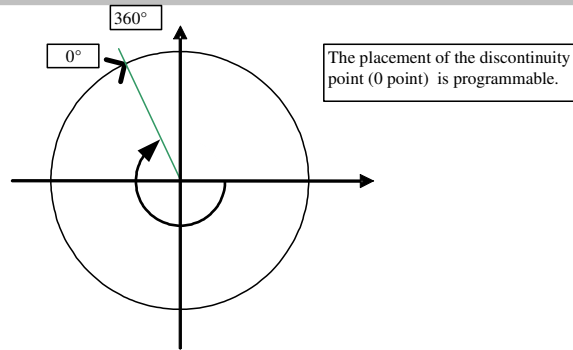

Figure 10 - Discontinuity Point Positioning

14.2.3. LNR Parameters

The LNR parameters, together with the clamping values, fully define the relation (the transfer function) between the digital angle and the output signal.

The shape of the MLX90316 transfer function from the digital angle value to the output voltage is described by the drawing below. Six segments can be programmed but the clamping levels are necessarily flat.

Two, three, or even five calibration points are then available, reducing the overall non-linearity of the IC by almost an order of magnitude each time. Three or five point calibration will be preferred by customers looking for excellent non-linearity figures. Two-point calibrations will be preferred by customers looking for a cheaper calibration set-up and shorter calibration time.

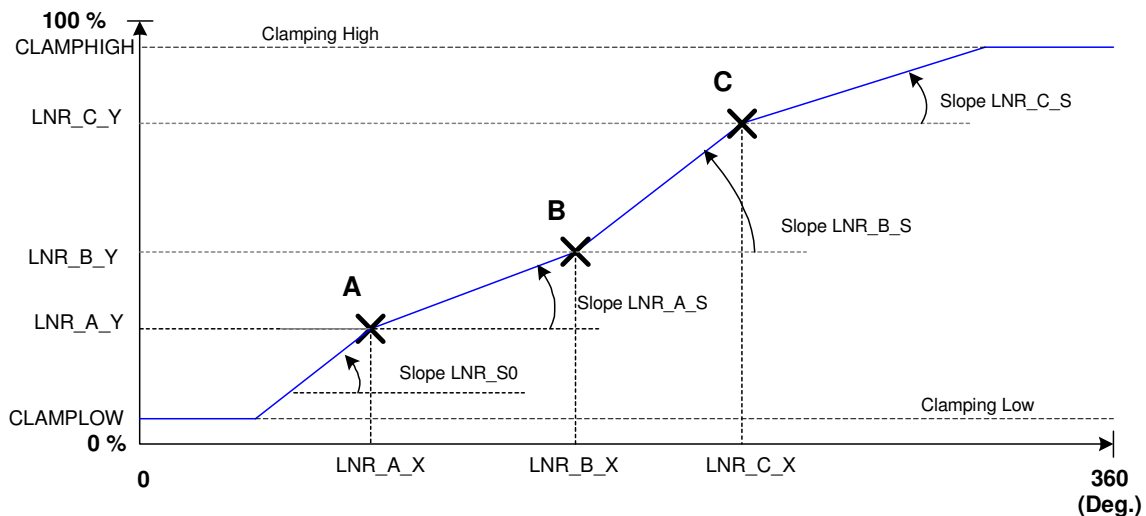

14.2.4. CLAMPING Parameters

The clamping levels are two independent values to limit the output voltage range. The CLAMP_LOW parameter adjusts the minimum output voltage level. The CLAMP_HIGH parameter sets the maximum output voltage level. Both parameters have 16 bits of adjustment. In analog mode, the resolution will be limited by the D/A converter (12 bits) to 0.024%VDD. In PWM mode, the resolution will be 0.024%DC. In SPI mode, the resolution is 14bits or 0.022deg over 360deg.

14.2.5. DEADZONE Parameter

The dead zone is defined as the angle window between 0 and 359.9999. When the digital angle lies in this zone, the IC is in fault mode (RESONFAULT must be set to “1” – See 14.6.1).

14.2.6. MLX90316 xDC- BCS ONLY

The MLX90316 BCS firmware offers the possibility to program a second output transfer characteristic of the single die version.

The following formula is used in the 90316BxS:

$$OUT2 = OUT2SlopeRatio * OUT1 + OUT2Offset$$

Range OUT2 = [Clamp_Low OUT2..Clamp_High OUT2]

OUT2 SLOPE RATIO Controls the slope ratio OUT1 vs OUT2. The ratio can be positive or negative. The example of MLX90316LDC-BCS-PPA is given in the figure below (slope = -1, OUT2 = -1 x slope OUT1 + 100 %).

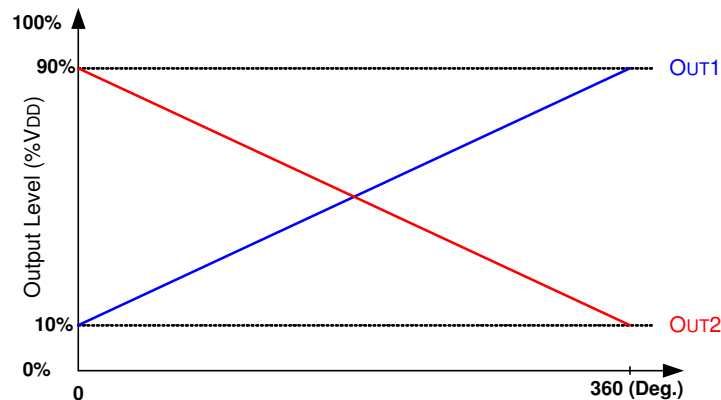

14.3. Identification

Parameter	Value	Unit
MELEXSID1	0 ... 65535	
MELEXSID2	0 ... 65535	
MELEXSID3	0 ... 65535	
CUSTOMERID1	0 ... 255	
CUSTOMERID2	0 ... 65535	
CUSTOMERID3	0 ... 65535	

Identification number: 40 bits freely useable by Customer for traceability purpose.

14.4. Sensor Front-End

Parameter	Value	Unit
HIGHSPEED	0 = Slow mode 1 = Fast mode	
ARGC	0 = disable 1 = enable	
AUTO_RG	0 = disable 1 = enable	
RoughGain	0 ... 15	
RGThresL	0 ... 15	
RGThresH	0 ... 15	

14.4.1. HIGHSPEED Parameter

The HIGHSPEED parameter defines the main frequency for the DSP.

- HIGHSPEED = 0 selects the Slow mode with a 7 MHz master clock.
- HIGHSPEED = 1 selects the Fast mode with a 20 MHz master clock.

For better noise performance, the Slow Mode must be enabled.

14.4.2. ARGC, AUTO_RG, RoughGain and FORCECRA75 Parameters

AUTO_RG and ARGC parameters enable the automatic gain control (AGC) of the analog chain. The AGC loop is based on

$$(V_x)^2 + (V_y)^2 = (\text{Amplitude})^2 = (\text{Radius})^2$$

and it targets an amplitude of 90% of the ADC input span.

At Start-Up phase, the gain stored in the parameter RoughGain is always used. Depending of the AUTO_RG and ARGC settings, the AGC regulation acts as follow:

- If ARGC is set, the regulation proceeds by jump to reach the target gain. Note that this regulation is only valid if the starting gain does not saturate the ADC. Melexis recommendation is to use $\text{RoughGain} \leq 3$ if $\text{ARGC}=1$.
- If ARGC is "0" and AUTO_RG is set to "1", the regulation adapts every cycle by one gain code the current gain to reach the 90% ADC span target. Note that if the value of RoughGain is too far from the actual gain, the chip will enter the normal operating mode (after the Start-Up phase) with an incorrect gain which will cause the device to go in diagnostic low (field too low/field too high – See section 15).
- If ARGC and AUTO_RG are "0", the AGC regulation is off and the gain used is the value stored in the parameter RoughGain. Melexis does not advise the use of this mode.

The parameter AUTO_RG activates the automatic regulation during normal operation of the device as background task.

The parameter FORCECRA75 modifies the target of the AGC algorithm to 75% - instead of 90% - of the ADC span (at start-up and in normal operation).

Melexis strongly recommend to set ARGC = "1", AUTO_RG = "1" and RoughGain ≤ 3 for all types of application. If the magnetic specifications of the application are well known and under control, the appropriate RoughGain can also be programmed with ARGC set to "0" and AUTO_RG to "1".

Please note that the angular errors listed in the section 10 are only valid if the AUTO_RG is activated. AUTO_RG avoids also the saturation of the analog chain and the associated linearity error.

The current gain (RG) can be read out with the PTC-04 and gives a rough indication of the applied magnetic flux density (Amplitude).

14.4.3. RGThresL, RGThresH Parameters

RGThresL & RGThresH define the boundaries within the gain setting (Rough Gain) is allowed to vary. Outside this range, the output is set in diagnostic low.

14.5. FILTER

Parameter	Value	Unit
FHYST	0 ... 11 ; step 0.04	deg
FILTER	0... 6	
FSWAP	0 1	

The MLX90316 includes 3 types of filters:

- Hysteresis Filter: programmable by the FHYST parameter
- Low Pass FIR Filters controlled with the Filter parameter
- Low Pass IIR Filter controlled with the Filter parameter and the coefficients FILTER A1 and FILTER A2

Note: if the parameter FSWAP is set to "1", the filtering is active on the digital angle. If set to "0", the filtering is active on the output transfer function.

14.5.1. Hysteresis Filter

The FHYST parameter is a hysteresis filter. The output value of the IC is not updated when the digital step is smaller than the programmed FHYST parameter value. The output value is modified when the increment is bigger than the hysteresis. The hysteresis filter reduces therefore the resolution to a level compatible with the internal noise of the IC. The hysteresis must be programmed to a value close to the noise level.

Please note that for the programmable version, the FHYST parameter is set to 4 by default. If you do not wish this feature, please set it to "0".

14.5.2. FIR Filters

The MLX90316 features 6 FIR filter modes controlled with Filter = 0...5. The transfer function is described below:

$$y_n = \frac{1}{\sum_{i=0}^j a_i} \sum_{i=0}^j a_i x_{n-i}$$

The characteristics of the filters no 0 to 5 is given in the Table 1.

Filter No (j)	0	1	2	3	4	5
Type	Disable	Finite Impulse Response				
Coefficients $a_0... a_5$	N/A	110000	121000	133100	111100	122210
Title	No Filter	Extra Light		Light		
90% Response Time	1	2	3	4	4	5
99% Response Time	1	2	3	4	4	5
Efficiency RMS (dB)	0	2.9	4.0	4.7	5.6	6.2
Efficiency P2P (dB)	0	2.9	3.6	5.0	6.1	7.0

Table 1 - FIR Filters Selection Table

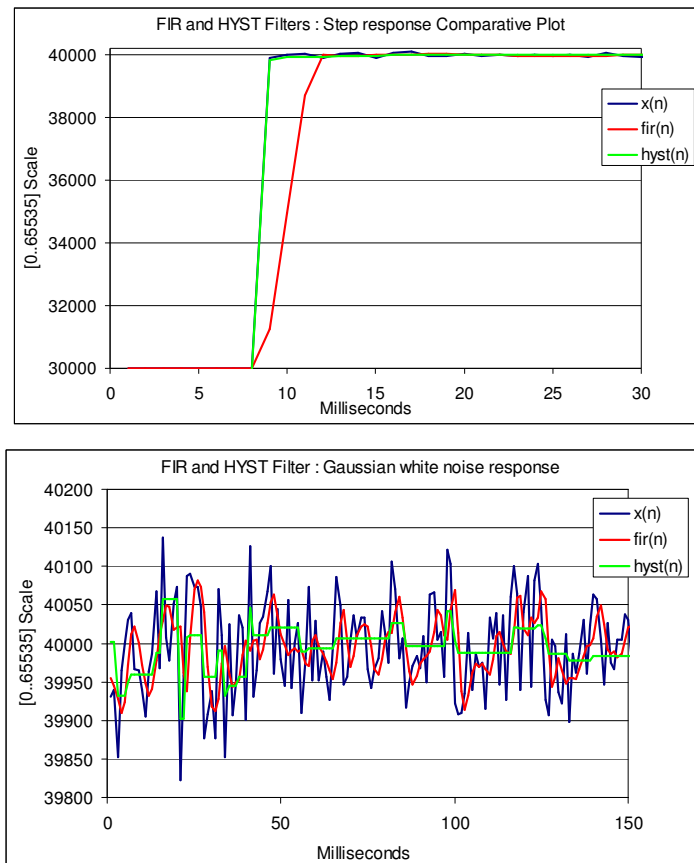

Figure 11 - Step Response and Noise Response for FIR (No 3) and FHYST=10

14.5.3. IIR Filters

The IIR Filter is enabled with Filter = 6. The diagram of the IIR Filter implemented in the MLX90316 is given in Figure 12. Only the parameter A1 and A2 are configurable (See Table 2).

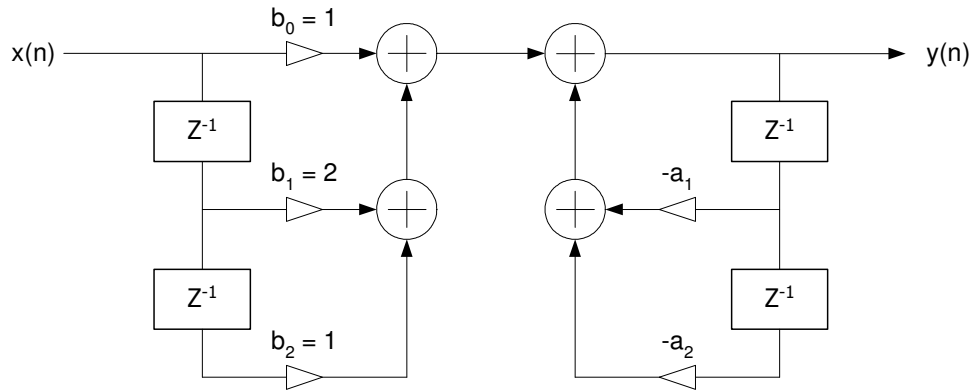

Figure 12 - IIR Diagram

Filter No	6					
Type	2 nd Order Infinite Impulse Response (IIR)					
Title	Medium & Strong					
90% Response Time	11	16	26	40	52	100
Efficiency RMS (dB)	9.9	11.4	13.6	15.3	16.2	>20
Efficiency P2P (dB)	12.9	14.6	17.1	18.8	20	>20
Coefficient A1	26112	28160	29120	30208	31296	31784
Coefficient A2	10752	12288	12992	13952	14976	15412

Table 2 - IIR Filter Selection Table

The Figure 13 shows the response of the filter to a Gaussian noise with default coefficient A1 and A2.