



Chipsmall Limited consists of a professional team with an average of over 10 year of expertise in the distribution of electronic components. Based in Hongkong, we have already established firm and mutual-benefit business relationships with customers from,Europe,America and south Asia,supplying obsolete and hard-to-find components to meet their specific needs.

With the principle of “Quality Parts,Customers Priority,Honest Operation,and Considerate Service”,our business mainly focus on the distribution of electronic components. Line cards we deal with include Microchip,ALPS,ROHM,Xilinx,Pulse,ON,Everlight and Freescale. Main products comprise IC,Modules,Potentiometer,IC Socket,Relay,Connector.Our parts cover such applications as commercial,industrial, and automotives areas.

We are looking forward to setting up business relationship with you and hope to provide you with the best service and solution. Let us make a better world for our industry!



Contact us

Tel: +86-755-8981 8866 Fax: +86-755-8427 6832

Email & Skype: info@chipsmall.com Web: www.chipsmall.com

Address: A1208, Overseas Decoration Building, #122 Zhenhua RD., Futian, Shenzhen, China





REVISIONS				
DRAWN	REV	DESCRIPTION	DATE	APPROVED
CP	01	INITIAL DESIGN	6/24/17	MS

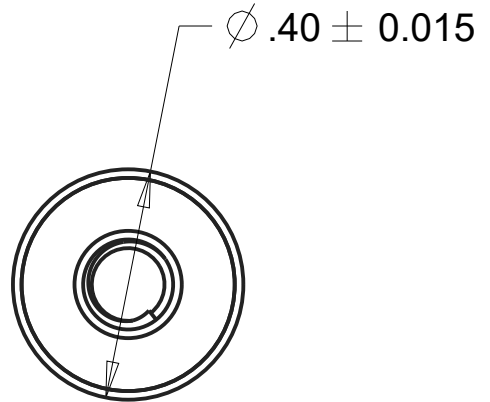

SCALE 3.000

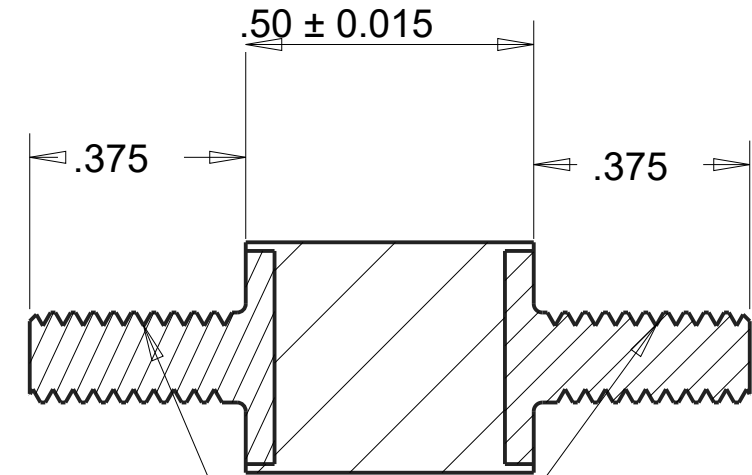

SECTION A-A

GROUP 2 MALE
INSERT #6-32
UNC-2A

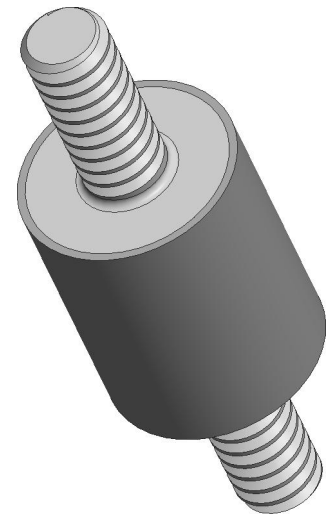

SCALE 3.000

NOTES:

1. CONTACT AREAS MUST BE 100% BONDED.

INSERTS:
MALE INSERT P/N: 021-1425
MATERIAL: S.A.E 1018 STEEL
FOR COATING DETAILS, SEE INSERT DRAWING.

MATERIAL:	ISOLOSS SL-20300	AEARO TECHNOLOGIES LLC * a 3M company		
UNITS:	IN	QUALITY CONTROL:	TITLE	
		MUST COMPLY WITH AEARO TECHNOLOGIES LLC SUPPLIER QUALITY MANUAL REQUIREMENTS	SANDWICH MOUNT, GROUP 2, MALE-MALE, ISOLOSS SL-20300	
		NOTES:	SIZE	ITEM CODE
		ANY FEATURE NOT DIMENSIONED IN PRINT MUST BE VISIBLY PRESENT, UTILIZE 3D CAD FOR CREATION	B	MM-200-UC06-SL20300
			DWG NO.	