



Chipsmall Limited consists of a professional team with an average of over 10 year of expertise in the distribution of electronic components. Based in Hongkong, we have already established firm and mutual-benefit business relationships with customers from,Europe,America and south Asia,supplying obsolete and hard-to-find components to meet their specific needs.

With the principle of “Quality Parts,Customers Priority,Honest Operation,and Considerate Service”,our business mainly focus on the distribution of electronic components. Line cards we deal with include Microchip,ALPS,ROHM,Xilinx,Pulse,ON,Everlight and Freescale. Main products comprise IC,Modules,Potentiometer,IC Socket,Relay,Connector.Our parts cover such applications as commercial,industrial, and automotives areas.

We are looking forward to setting up business relationship with you and hope to provide you with the best service and solution. Let us make a better world for our industry!



Contact us

Tel: +86-755-8981 8866 Fax: +86-755-8427 6832

Email & Skype: info@chipsmall.com Web: www.chipsmall.com

Address: A1208, Overseas Decoration Building, #122 Zhenhua RD., Futian, Shenzhen, China



MM74C192 • MM74C193

Synchronous 4-Bit Up/Down Decade Counter • Synchronous 4-Bit Up/Down Binary Counter

General Description

The MM74C192 and MM74C193 up/down counters are monolithic complementary MOS (CMOS) integrated circuits. The MM74C192 is a BCD counter, while the MM74C193 is a binary counter.

Counting up and counting down is performed by two count inputs, one being held high while the other is clocked. The outputs change on the positive-going transition of this clock.

These counters feature preset inputs that are set when load is a logical "0" and a clear which forces all outputs to "0" when it is at a logical "1". The counters also have carry and borrow outputs so that they can be cascaded using no external circuitry.

Features

- High noise margin: 1V guaranteed
- Tenth power TTL compatible: Drive 2 LPTTL loads
- Wide supply range: 3V to 15V
- Carry and borrow outputs for N-bit cascading
- Asynchronous clear
- High noise immunity: 0.45 V_{CC} (typ.)

Ordering Code:

Order Number	Package Number	Package Description
MM74C192N	N16E	16-Lead Plastic Dual-In-Line Package (PDIP), JEDEC MS-001, 0.300" Wide
MM74C193M	M16A	16-Lead Small Outline Integrated Circuit (SOIC), JEDEC MS-012, 0.150" Narrow
MM74C193N	N16E	16-Lead Plastic Dual-In-Line Package (PDIP), JEDEC MS-001, 0.300" Wide

Device also available in Tape and Reel. Specify by appending suffix letter "X" to the ordering code.

Connection Diagram

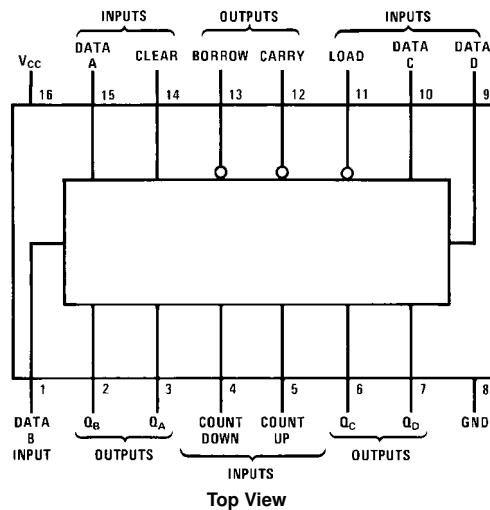

MM74C192 • MM74C193 Synchronous 4-Bit Up/Down Decade Counter • Synchronous 4-Bit Up/Down Binary Counter

Absolute Maximum Ratings(Note 1)

Voltage at Any Pin	-0.3V to $V_{CC} + 0.3V$
Operating Temperature Range (T_A)	-55°C to +125°C
Storage Temperature Range (T_S)	-65°C to +150°C
Maximum V_{CC} Voltage	18V
Power Dissipation (P_D)	
Dual-In-Line	700 mW
Small Outline	500 mW
Operating V_{CC} Range	3V to 15V
Lead Temperature (T_A)	
(Soldering, 10 seconds)	260°C

Note 1: "Absolute Maximum Ratings" are those values beyond which the safety of the device cannot be guaranteed. Except for "Operating Temperature Range" they are not meant to imply that the devices should be operated at these limits. The Electrical Characteristics table provides conditions for actual device operation.

DC Electrical Characteristics

Min/Max limits apply across temperature range unless otherwise noted

Symbol	Parameter	Conditions	Min	Typ	Max	Units
CMOS TO CMOS						
$V_{IN(1)}$	Logical "1" Input Voltage	$V_{CC} = 5V$ $V_{CC} = 10V$	3.5 8.0			V
$V_{IN(0)}$	Logical "0" Input Voltage	$V_{CC} = 5V$ $V_{CC} = 10V$			1.5 2.0	V
$V_{OUT(1)}$	Logical "1" Output Voltage	$V_{CC} = 5V, I_O = -10 \mu A$ $V_{CC} = 10V, I_O = -10 \mu A$	4.5 9.0			V
$V_{OUT(0)}$	Logical "0" Output Voltage	$V_{CC} = 5V, I_O = 10 \mu A$ $V_{CC} = 10V, I_O = 10 \mu A$			0.5 1.0	V
$I_{IN(1)}$	Logical "1" Input Current	$V_{CC} = 15V, V_{IN} = 15V$		0.005	1.0	μA
$I_{IN(0)}$	Logical "0" Input Current	$V_{CC} = 15V, V_{IN} = 0V$	-1.0	-0.005		μA
I_{CC}	Supply Current	$V_{CC} = 15V$		0.05	300	μA
CMOS TO LPTTL INTERFACE						
$V_{IN(1)}$	Logical "1" Input Voltage	$V_{CC} = 4.75V$	$V_{CC} - 1.5$			V
$V_{IN(0)}$	Logical "0" Input Voltage	$V_{CC} = 4.75V$			0.8	V
$V_{OUT(1)}$	Logical "1" Output Voltage	$V_{CC} = 4.75V, I_O = -100 \mu A$	2.4			V
$V_{OUT(0)}$	Logical "0" Output Voltage	$V_{CC} = 4.75V, I_O = 360 \mu A$			0.4	V
OUTPUT DRIVE (See Family Characteristics Data Sheet) (Short Circuit Current)						
I_{SOURCE}	Output Source Current	$V_{CC} = 5V, V_{IN(0)} = 0V$ $T_A = 25^\circ C, V_{OUT} = 0V$	-1.75			mA
I_{SOURCE}	Output Source Current	$V_{CC} = 10V, V_{IN(0)} = 0V$ $T_A = 25^\circ C, V_{OUT} = 0V$	-8			mA
I_{SINK}	Output Sink Current	$V_{CC} = 5V, V_{IN(1)} = 5V$ $T_A = 25^\circ C, V_{OUT} = V_{CC}$	1.75			mA
I_{SINK}	Output Sink Current	$V_{CC} = 10V, V_{IN(1)} = 10V$ $T_A = 25^\circ C, V_{OUT} = V_{CC}$	8			mA

AC Electrical Characteristics (Note 2)

$T_A = 25^\circ\text{C}$, $C_L = 50\text{ pF}$, unless otherwise noted

Symbol	Parameter	Conditions	Min	Typ	Max	Units
t_{pd}	Propagation Delay	$V_{CC} = 5\text{V}$		250	400	ns
	Time to Q from Count Up or Down	$V_{CC} = 10\text{V}$		100	160	
t_{pd}	Propagation Delay	$V_{CC} = 5\text{V}$		120	200	ns
	Time to Q Borrow from Count Down	$V_{CC} = 10\text{V}$		50	80	
t_{pd}	Propagation Delay	$V_{CC} = 5\text{V}$		120	200	ns
	Time to Carry from Count Up	$V_{CC} = 10\text{V}$		50	80	
t_S	Time Prior to Load that Data Must be Present	$V_{CC} = 5\text{V}$		100	160	ns
		$V_{CC} = 10\text{V}$		30	50	
t_W	Minimum Clear Pulse Width	$V_{CC} = 5\text{V}$		300	480	ns
		$V_{CC} = 10\text{V}$		120	190	
t_W	Minimum Load Pulse Width	$V_{CC} = 5\text{V}$		100	160	ns
		$V_{CC} = 10\text{V}$		40	65	
t_{pd0}	Propagation Delay	$V_{CC} = 5\text{V}$		300	480	ns
t_{pd1}	Time to Q from Load	$V_{CC} = 10\text{V}$		120	190	ns
t_W	Minimum Count Pulse Width	$V_{CC} = 5\text{V}$		120	200	ns
		$V_{CC} = 10\text{V}$		35	80	
f_{MAX}	Maximum Count Frequency	$V_{CC} = 5\text{V}$	2.5	4		MHz
		$V_{CC} = 10\text{V}$	6	10		
t_r	Count Rise and Fall Time	$V_{CC} = 5\text{V}$			15	μs
t_f		$V_{CC} = 10\text{V}$			5	
C_{IN}	Input Capacitance	(Note 3)		5		pF
C_{PD}	Power Dissipation Capacitance	(Note 4)		100		pF

Note 2: AC Parameters are guaranteed by DC correlated testing.

Note 3: Capacitance is guaranteed by periodic testing.

Note 4: C_{PD} determines the no load AC power consumption of any CMOS device. For complete explanation, see Application Note AN-90.

Cascading Packages

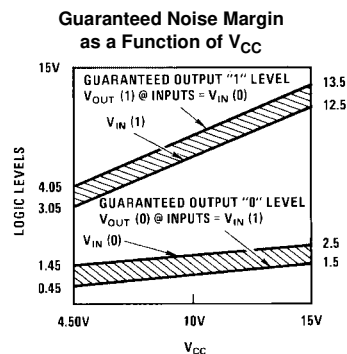
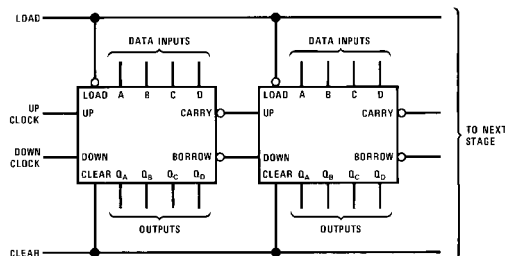

Timing Diagrams

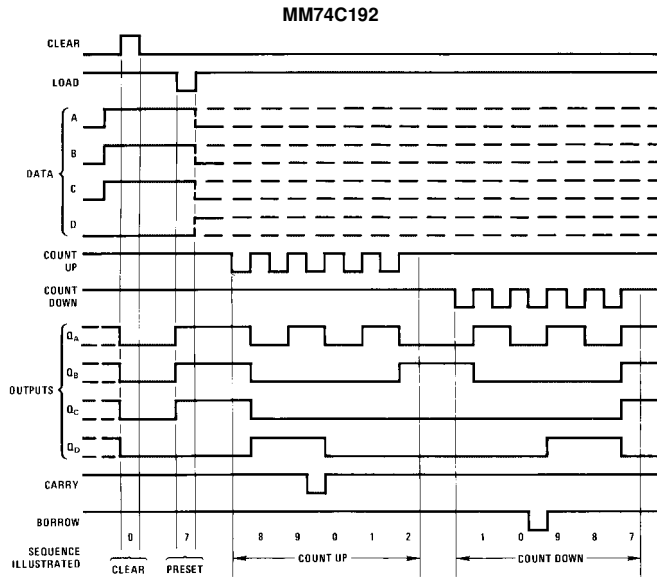

Note A: Clear outputs to zero.

Note B: Load (preset) to binary thirteen.

Note C: Count up to fourteen, fifteen, carry, zero, one and two.

Note D: Count down to one, zero, borrow, fifteen, fourteen, and thirteen.

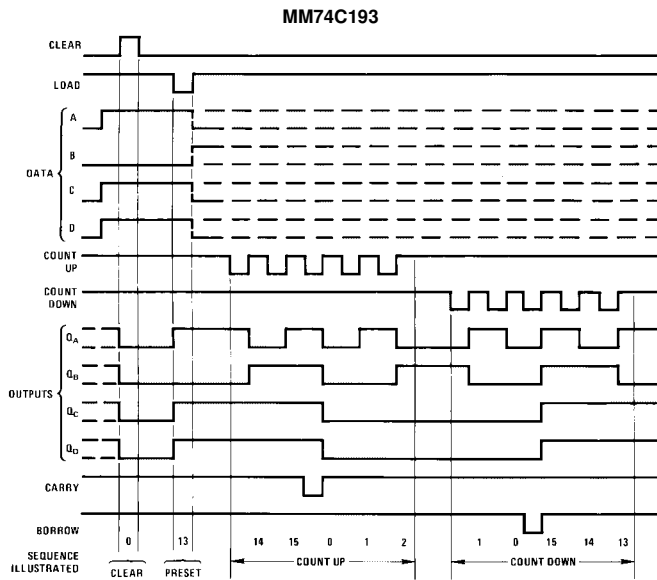

Note A: Clear outputs to zero.

Note B: Load (preset) to BCD seven.

Note C: Count up to eight, nine, carry, zero, one, and two.

Note D: Count down to one, zero, borrow, nine, eight, and seven.

Note E: Clear overrides load, data, and count inputs.

Note F: When counting up, count down input must be HIGH; when counting down, count-up input must be HIGH.

Physical Dimensions inches (millimeters) unless otherwise noted

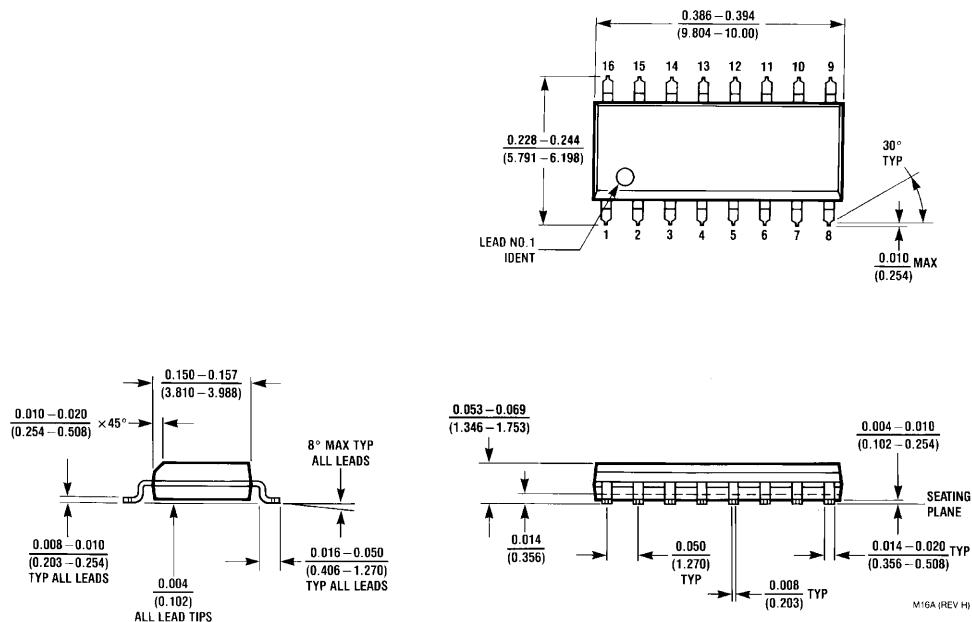

16-Lead Small Outline Integrated Circuit (SOIC), JEDEC MS-012, 0.150" Narrow Package Number M16A

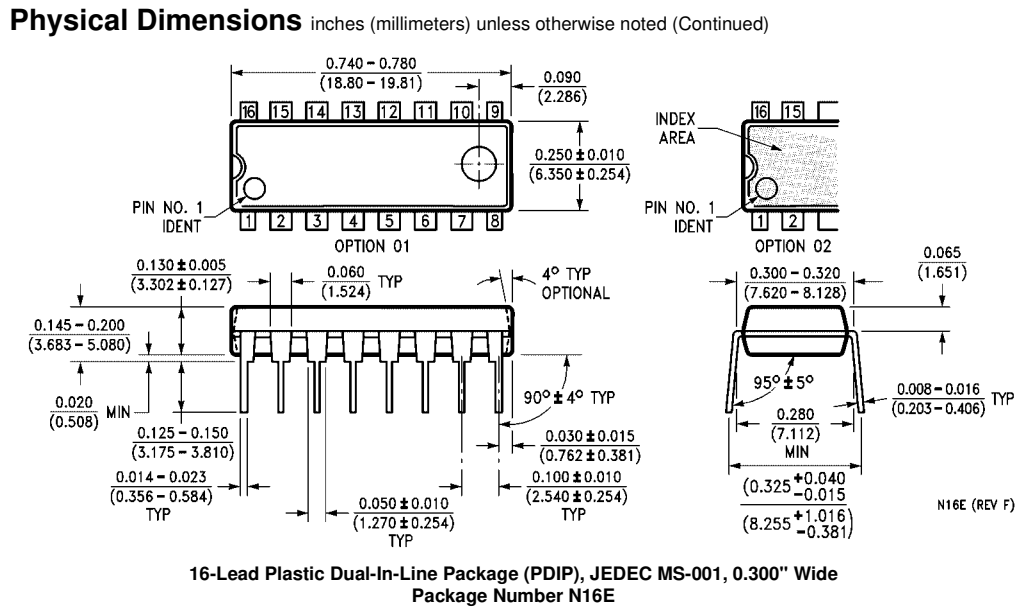

Fairchild does not assume any responsibility for use of any circuitry described, no circuit patent licenses are implied and Fairchild reserves the right at any time without notice to change said circuitry and specifications.

LIFE SUPPORT POLICY

FAIRCHILD'S PRODUCTS ARE NOT AUTHORIZED FOR USE AS CRITICAL COMPONENTS IN LIFE SUPPORT DEVICES OR SYSTEMS WITHOUT THE EXPRESS WRITTEN APPROVAL OF THE PRESIDENT OF FAIRCHILD SEMICONDUCTOR CORPORATION. As used herein:

1. Life support devices or systems are devices or systems which, (a) are intended for surgical implant into the body, or (b) support or sustain life, and (c) whose failure to perform when properly used in accordance with instructions for use provided in the labeling, can be reasonably expected to result in a significant injury to the user.
2. A critical component in any component of a life support device or system whose failure to perform can be reasonably expected to cause the failure of the life support device or system, or to affect its safety or effectiveness.

www.fairchildsemi.com