



Chipsmall Limited consists of a professional team with an average of over 10 year of expertise in the distribution of electronic components. Based in Hongkong, we have already established firm and mutual-benefit business relationships with customers from,Europe,America and south Asia,supplying obsolete and hard-to-find components to meet their specific needs.

With the principle of “Quality Parts,Customers Priority,Honest Operation,and Considerate Service”,our business mainly focus on the distribution of electronic components. Line cards we deal with include Microchip,ALPS,ROHM,Xilinx,Pulse,ON,Everlight and Freescale. Main products comprise IC,Modules,Potentiometer,IC Socket,Relay,Connector.Our parts cover such applications as commercial,industrial, and automotives areas.

We are looking forward to setting up business relationship with you and hope to provide you with the best service and solution. Let us make a better world for our industry!



Contact us

Tel: +86-755-8981 8866 Fax: +86-755-8427 6832

Email & Skype: info@chipsmall.com Web: www.chipsmall.com

Address: A1208, Overseas Decoration Building, #122 Zhenhua RD., Futian, Shenzhen, China



MM74C89 64-Bit 3-STATE Random Access Read/Write Memory

General Description

The MM74C89 is a 16-word by 4-bit random access read/write memory. Inputs to the memory consist of four address lines, four data input lines, a write enable line and a memory enable line. The four binary address inputs are decoded internally to select each of the 16 possible word locations. An internal address register latches the address information on the positive to negative transition of the memory enable input. The four 3-STATE data output lines working in conjunction with the memory enable input provide for easy memory expansion.

Address Operation: Address inputs must be stable t_{SA} prior to the positive to negative transition of memory enable. It is thus not necessary to hold address information stable for more than t_{HA} after the memory is enabled (positive to negative transition of memory enable).

Write Operation: Information present at the data inputs is written into the memory at the selected address by bringing write enable and memory enable LOW.

Read Operation: The complement of the information which was written into the memory is non-destructively read out at the four outputs. This is accomplished by selecting the desired address and bringing memory enable LOW and write enable HIGH.

When the device is writing or disabled the output assumes a 3-STATE (Hi-z) condition.

Features

- Wide supply voltage range: 3.0V to 15V
- Guaranteed noise margin: 1.0V
- High noise immunity: $0.45 V_{CC}$ (typ.)
- Low power TTL compatibility:
fan out of 2 driving 74L
- Low power consumption: 100 nW/package (typ.)
- Fast access time: 130 ns (typ.) at $V_{CC} = 10V$
- 3-STATE output

Note: The timing is different than the DM7489 in that a positive to negative transition of the memory enable must occur for the memory to be selected.

Ordering Code:

Order Number	Package Number	Package Description
MM74C89N	N16E	16-Lead Plastic Dual-In-Line Package (PDIP), JEDEC MS-001, 0.300" Wide

Connection Diagram

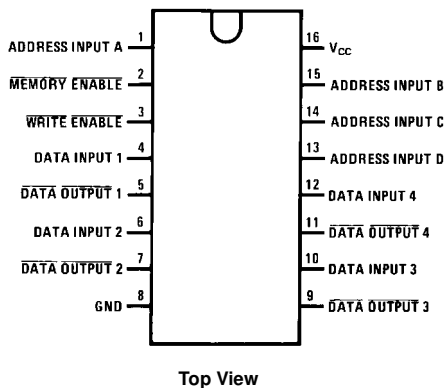

Truth Table

ME	WE	Operation	Condition of Outputs
L	L	Write	3-STATE
L	H	Read	Complement of Selected Word
H	L	Inhibit, Storage	3-STATE
H	H	Inhibit, Storage	3-STATE

Logic Diagram

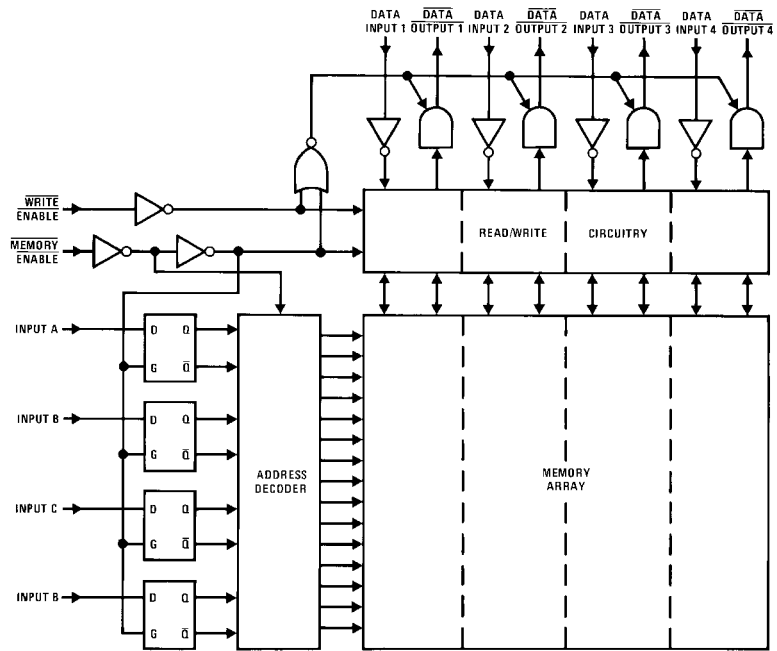

Absolute Maximum Ratings(Note 1)

Voltage at any Pin	-0.3V to $V_{CC} + 0.3V$
Operating Temperature Range	-55°C to +125°C
Storage Temperature Range (T_S)	-65°C to +150°C
Power Dissipation (P_D)	
Dual-In-Line	700 mW
Small Outline	500 mW
Operating V_{CC} Range	3.0V to 15V
Absolute Maximum V_{CC}	18V
Lead Temperature (T_L)	
(Soldering, 10 seconds)	260°C

Note 1: "Absolute Maximum Ratings" are those values beyond which the safety of the device cannot be guaranteed. Except for "Operating Range" they are not meant to imply that the devices should be operated at these limits. The table of "Electrical Characteristics" provides conditions for actual device operation.

DC Electrical Characteristics

Min/Max limits apply across temperature range, unless otherwise noted

Symbol	Parameter	Conditions	Min	Typ	Max	Units
CMOS TO CMOS						
$V_{IN(1)}$	Logical "1" Input Voltage	$V_{CC} = 5.0V$ $V_{CC} = 10V$	3.5 8.0			V
$V_{IN(0)}$	Logical "0" Input Voltage	$V_{CC} = 5.0V$ $V_{CC} = 10V$			1.5 2.0	V
$V_{OUT(1)}$	Logical "1" Output Voltage	$V_{CC} = 5.0V, I_O = -10 \mu A$ $V_{CC} = 10V, I_O = -10 \mu A$	4.5 9.0			V
$V_{OUT(0)}$	Logical "0" Output Voltage	$V_{CC} = 5.0V, I_O = +10 \mu A$ $V_{CC} = 10V, I_O = +10 \mu A$			0.5 1.0	V
$I_{IN(1)}$	Logical "1" Input Current	$V_{CC} = 15V, V_{IN} = 15V$		-0.005	1.0	μA
$I_{IN(0)}$	Logical "0" Input Current	$V_{CC} = 15V, V_{IN} = 0V$	-1.0	-0.005		μA
I_{OZ}	Output Current in High Impedance State	$V_{CC} = 15V, V = 15V$ $V_{CC} = 15V, V_O = 0V$	-1.0	0.005 -0.005	1.0	μA
I_{CC}	Supply Current	$V_{CC} = 15V$		0.05	300	μA
CMOS/LPTTL INTERFACE						
$V_{IN(1)}$	Logical "1" Input Voltage	$V_{CC} = 4.75V$	$V_{CC} - 1.5$			V
$V_{IN(0)}$	Logical "0" Input Voltage	$V_{CC} = 4.75V$			0.8	V
$V_{OUT(1)}$	Logical "1" Output Voltage	$V_{CC} = 4.75V, I_O = -360 \mu A$	2.4			V
$V_{OUT(0)}$	Logical "0" Output Voltage	$V_{CC} = 4.75V, I_O = +360 \mu A$			0.4	V
OUTPUT DRIVE (See 54C/74C Family Characteristics Data Sheet) (Short Circuit Current)						
I_{SOURCE}	Output Source Current (P-Channel)	$V_{CC} = 5.0V, V_{OUT} = 0V$ $T_A = 25^\circ C$	-1.75	-3.3		mA
I_{SOURCE}	Output Source Current (P-Channel)	$V_{CC} = 10V, V_{OUT} = 0V$ $T_A = 25^\circ C$	-8.0	-15		mA
I_{SINK}	Output Sink Current (N-Channel)	$V_{CC} = 5.0V, V_{OUT} = V_{CC}$ $T_A = 25^\circ C$	1.75	3.6		mA
I_{SINK}	Output Sink Current (N-Channel)	$V_{CC} = 10V, V_{OUT} = V_{CC}$ $T_A = 25^\circ C$	8.0	16		mA

AC Electrical Characteristics (Note 2)T_A = 25°C, C_L = 50 pF, unless otherwise noted

Symbol	Parameter	Conditions	Min	Typ	Max	Units
t _{pd}	Propagation Delay from Memory Enable	V _{CC} = 5V V _{CC} = 10V		270 100	500 220	ns
t _{ACC}	Access Time from Address Input	V _{CC} = 5V V _{CC} = 10V		350 130	650 280	ns
t _{SA}	Address Setup Time	V _{CC} = 5V V _{CC} = 10V	150 60			ns
t _{HA}	Address Hold Time	V _{CC} = 5V V _{CC} = 10V	60 40			ns
t _{ME}	Memory Enable Pulse Width	V _{CC} = 5V V _{CC} = 10V	400 150	250 90		ns
t _{SR}	Write Enable Setup Time for a Read	V _{CC} = 5V V _{CC} = 10V	0 0			ns
t _{WS}	Write Enable Setup Time for a Write	V _{CC} = 5V V _{CC} = 10V			t _{ME} t _{ME}	ns
t _{WE}	Write Enable Pulse Width	V _{CC} = 5V, t _{WS} = 0 V _{CC} = 10V, t _{WS} = 0	300 100	160 60		ns
t _{HD}	Data Input Hold Time	V _{CC} = 5V V _{CC} = 10V	50 25			ns
t _{SD}	Data Input Setup	V _{CC} = 5V V _{CC} = 10V	50 25			ns
t _{1H} , t _{0H}	Propagation Delay from a Logical "1" or Logical "0" to the High Impedance State from Memory Enable	V _{CC} = 5V, C _L = 5 pF, R _L = 10k V _{CC} = 10V, C _L = 5 pF, R _L = 10k		180 -85	300 120	ns
t _{1H} , t _{0H}	Propagation Delay from a Logical "1" or Logical "0" to the High Impedance State from Write Enable	V _{CC} = 50V, C _L = 5 pF, R _L = 10k V _{CC} = 10V, C _L = 5 pF, R _L = 10k		180 85	300 120	ns
C _{IN}	Input Capacity	Any Input (Note 3)		5		pF
C _{OUT}	Output Capacity	Any Output (Note 3)		6.5		pF
C _{PD}	Power Dissipation Capacity	(Note 4)		230		pF

Note 2: AC Parameters are guaranteed by DC correlated testing.**Note 3:** Capacitance is guaranteed by periodic testing.**Note 4:** C_{PD} determines the no load AC power consumption of any CMOS device. For complete explanation see Family Characteristics application note, AN-90.

AC Test Circuits

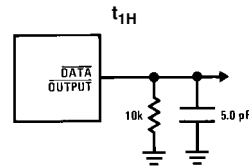
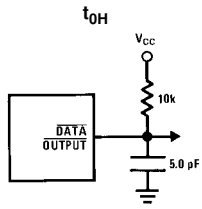

Switching Time Waveforms

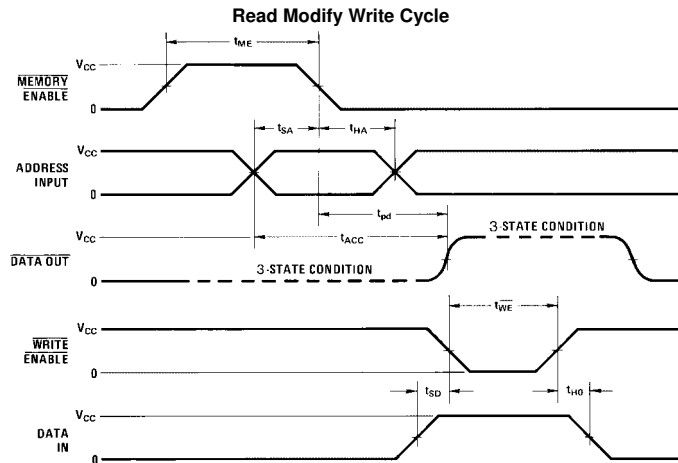
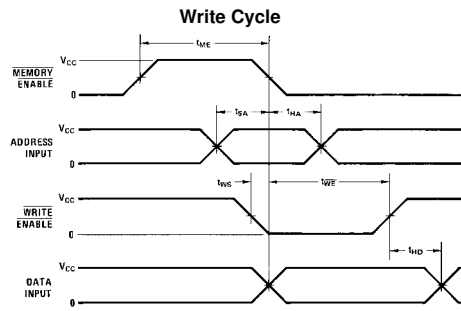
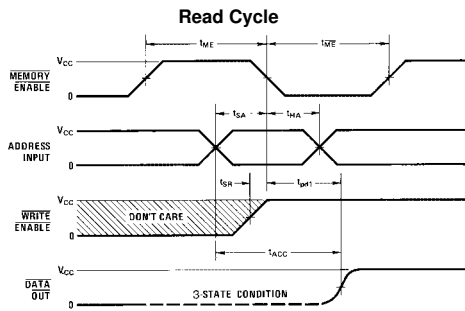
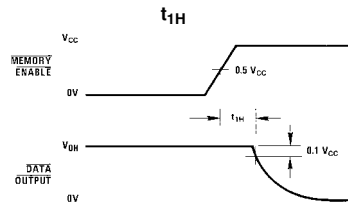
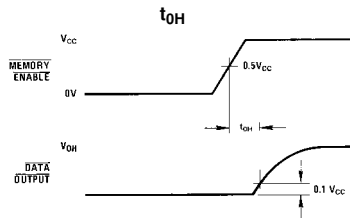

$t_f = 10$ ns
 $t_r = 60$ ns

