



Chipsmall Limited consists of a professional team with an average of over 10 year of expertise in the distribution of electronic components. Based in Hongkong, we have already established firm and mutual-benefit business relationships with customers from,Europe,America and south Asia,supplying obsolete and hard-to-find components to meet their specific needs.

With the principle of “Quality Parts,Customers Priority,Honest Operation,and Considerate Service”,our business mainly focus on the distribution of electronic components. Line cards we deal with include Microchip,ALPS,ROHM,Xilinx,Pulse,ON,Everlight and Freescale. Main products comprise IC,Modules,Potentiometer,IC Socket,Relay,Connector.Our parts cover such applications as commercial,industrial, and automotives areas.

We are looking forward to setting up business relationship with you and hope to provide you with the best service and solution. Let us make a better world for our industry!



## Contact us

Tel: +86-755-8981 8866 Fax: +86-755-8427 6832

Email & Skype: info@chipsmall.com Web: www.chipsmall.com

Address: A1208, Overseas Decoration Building, #122 Zhenhua RD., Futian, Shenzhen, China



## MM74C906 • MM74C907

### Hex Open Drain N-Channel Buffers • Hex Open Drain P-Channel Buffers

#### General Description

The MM74C906 and MM74C907 buffers employ monolithic CMOS technology in achieving open drain outputs. The MM74C906 consists of six inverters driving six N-channel devices; and the MM74C907 consists of six inverters driving six P-channel devices. The open drain feature of these buffers makes level shifting or wire AND and wire OR functions by just the addition of pull-up or pull-down resistors. All inputs are protected from static discharge by diode clamps to  $V_{CC}$  and to ground.

#### Features

- Wide supply voltage range: 3V to 15V
- Guaranteed noise margin: 1V
- High noise immunity:  $0.45 V_{CC}$  (typ.)
- High current sourcing and sinking open drain outputs

#### Ordering Code:

Order Number	Package Number	Package Description
MM74C906M	M14A	14-Lead Small Outline Integrated Circuit (SOIC), JEDEC MS-012, 0.150" Narrow
MM74C906N	N14A	14-Lead Plastic Dual-In-Line Package (PDIP), JEDEC MS-001, 0.300" Wide
MM74C907N	N14A	14-Lead Plastic Dual-In-Line Package (PDIP), JEDEC MS-001, 0.300" Wide

Devices also available in Tape and Reel. Specify by appending the suffix letter "X" to the ordering code.

#### Connection Diagram

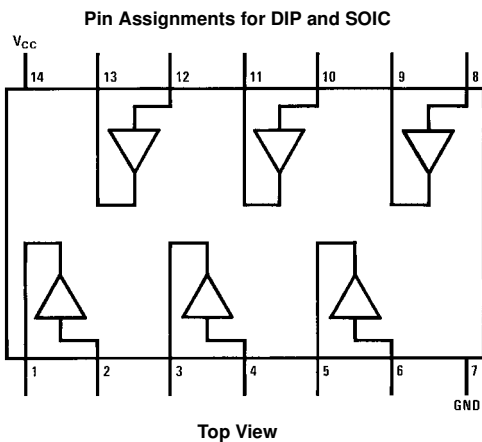

#### Logic Diagrams

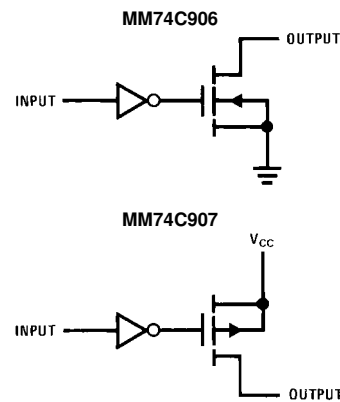

Absolute Maximum Ratings (Note 1)		Operating $V_{CC}$ Range	3V to 15V
Voltage at Any Input Pin	-0.3V to $V_{CC} + 0.3V$	Absolute Maximum $V_{CC}$	18V
Voltage at Any Output Pin		Lead Temperature ( $T_L$ )	260°C
Operating Temperature Range		(Soldering, 10 seconds)	
MM74C906/MM74C907	-40°C to +85°C		
Storage Temperature Range	-65°C to +150°C		
Power Dissipation			
Dual-In-Line	700 mW		
Small Outline	500 mW		

**Note 1:** "Absolute Maximum Ratings" are those values beyond which the safety of the device cannot be guaranteed. Except for "Operating Temperature Range" they are not meant to imply that the devices should be operated at these limits. The table of "Electrical Characteristics" provides conditions for actual device operation.

## DC Electrical Characteristics

Min/Max limits apply across temperature range unless otherwise noted

Symbol	Parameter	Conditions	Min	Typ	Max	Units
<b>CMOS TO CMOS</b>						
$V_{IN(1)}$	Logical "1" Input Voltage	$V_{CC} = 5V$ $V_{CC} = 10V$	3.5 8.0			V V
$V_{IN(0)}$	Logical "0" Input Voltage	$V_{CC} = 5V$ $V_{CC} = 10V$			1.5 2	V V
$I_{IN(1)}$	Logical "1" Input Current	$V_{CC} = 15V, V_{IN} = 15V$		0.005	1	$\mu A$
$I_{IN(0)}$	Logical "0" Input Current	$V_{CC} = 15V, V_{IN} = 0V$	-1.0	-0.005		$\mu A$
$I_{CC}$	Supply Current	$V_{CC} = 15V, \text{Output Open}$		0.05	15	$\mu A$
	Output Leakage			0.005	5	$\mu A$
	MM74C906	$V_{CC} = 4.75V, V_{IN} = V_{CC} - 1.5V$ $V_{CC} = 4.75V, V_{OUT} = 18V$				$\mu A$
	MM74C907	$V_{CC} = 4.75V, V_{IN} = 1V + 0.1 V_{CC}$ $V_{CC} = 4.75V, V_{OUT} = V_{CC} - 18V$		0.005	5	$\mu A$
<b>CMOS/LPTTL INTERFACE</b>						
$V_{IN(1)}$	Logical "1" Input Voltage	$V_{CC} = 4.75V$	$V_{CC} - 1.5V$			V
$V_{IN(0)}$	Logical "0" Input Voltage	$V_{CC} = 4.75V$			0.8	V
<b>OUTPUT DRIVE CURRENT</b>						
	MM74C906	$V_{CC} = 4.75V, V_{IN} = 1V + 0.1 V_{CC}$ $V_{CC} = 4.75V, V_{OUT} = 0.5V$ $V_{CC} = 4.75V, V_{OUT} = 1.0V$	2.1 4.2	8.0 12.0		mA mA
	MM74C907	$V_{CC} = 4.75V, V_{IN} = V_{CC} - 1.5V$ $V_{CC} = 4.75V, V_{OUT} = V_{CC} - 0.5V$ $V_{CC} = 4.75V, V_{OUT} = V_{CC} - 1V$	-1.05 -2.1	-1.5 -3.0		mA mA
	MM74C906	$V_{CC} = 10V, V_{IN} = 2V$ $V_{CC} = 10V, V_{OUT} = 0.5V$ $V_{CC} = 10V, V_{OUT} = 1V$	4.2 8.4	20 30		mA mA
	MM74C907	$V_{CC} = 10V, V_{IN} = 8V$ $V_{CC} = 10V, V_{OUT} = 9.5V$ $V_{CC} = 10V, V_{OUT} = 9V$	-2.1 -4.2	-4.0 -8.0		mA mA

## AC Electrical Characteristics (Note 2)

$T_A = 25^\circ\text{C}$ ,  $C_L = 50\text{ pF}$ , unless otherwise specified

Symbol	Parameter	Conditions	Min	Typ	Max	Units
$t_{pd}$	Propagation Delay Time to a Logical "0" MM74C906	$V_{CC} = 5.0\text{V}$ , $R = 10\text{k}$			150	ns
		$V_{CC} = 10\text{V}$ , $R = 10\text{k}$			75	ns
		$V_{CC} = 5.0\text{V}$ (Note 3)			$150 + 0.7 RC$	ns
		$V_{CC} = 10\text{V}$ (Note 3)			$75 + 0.7 RC$	ns
$t_{pd}$	Propagation Delay Time to a Logical "1" MM74C906	$V_{CC} = 5.0\text{V}$ (Note 3)			$150 + 0.7 RC$	ns
		$V_{CC} = 10\text{V}$ (Note 3)			$75 + 0.7 RC$	ns
		$V_{CC} = 5.0\text{V}$ , $R = 10\text{k}$			150	ns
		$V_{CC} = 10\text{V}$ , $R = 10\text{k}$			75	ns
$C_{IN}$	Input Capacitance	(Note 4)		5.0		pF
$C_{OUT}$	Output Capacity	(Note 4)		20		pF
$C_{PD}$	Power Dissipation Capacity	(Note 5) Per Buffer		30		pF

**Note 2:** AC Parameters are guaranteed by DC correlated testing.

**Note 3:** "C" used in calculating propagation includes output load capacity ( $C_L$ ) plus device output capacity ( $C_{OUT}$ ).

**Note 4:** Capacitance is guaranteed by periodic testing.

**Note 5:**  $C_{PD}$  determines the no load AC power consumption of any CMOS device. For complete explanation see Family Characteristics Application Note, AN-90. (Assumes outputs are open).

## Typical Applications

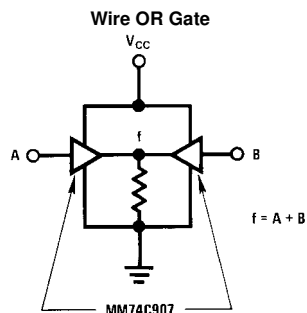

**Note:** Can be extended to more than 2 inputs.

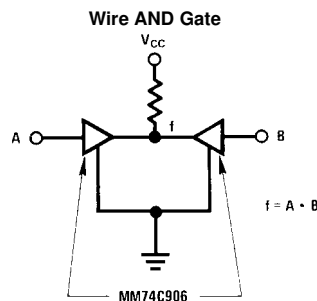

**Note:** Can be extended to more than 2 inputs.

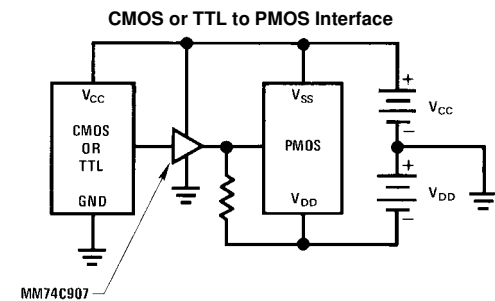

**Note:**  $V_{CC} + V_{DD} \leq 18\text{V}$

$V_{CC} \leq 15\text{V}$

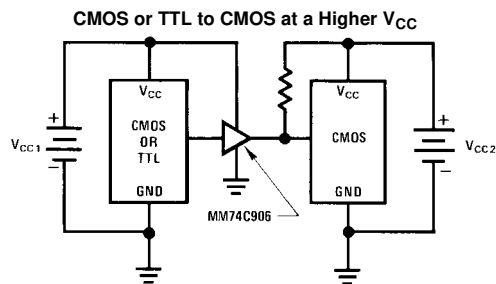

**Physical Dimensions** inches (millimeters) unless otherwise noted

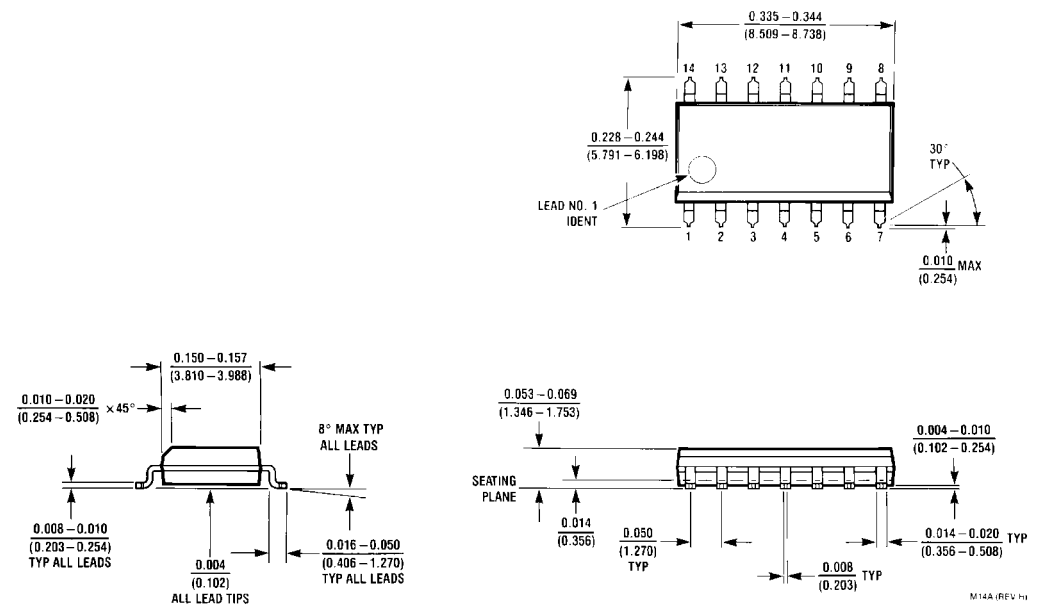

**14-Lead Small Outline Integrated Circuit (SOIC), JEDEC MS-012, 0.150" Narrow  
Package Number M14A**

**Physical Dimensions** inches (millimeters) unless otherwise noted (Continued)

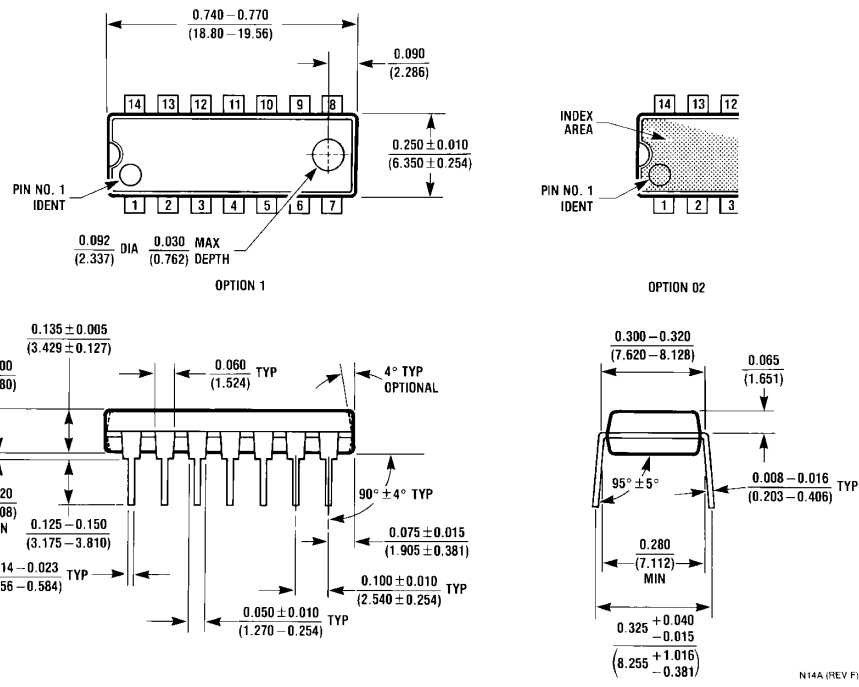

**14-Lead Plastic Dual-In-Line Package (PDIP), JEDEC MS-001, 0.300" Wide Package Number N14A**

Fairchild does not assume any responsibility for use of any circuitry described, no circuit patent licenses are implied and Fairchild reserves the right at any time without notice to change said circuitry and specifications.

**LIFE SUPPORT POLICY**

FAIRCHILD'S PRODUCTS ARE NOT AUTHORIZED FOR USE AS CRITICAL COMPONENTS IN LIFE SUPPORT DEVICES OR SYSTEMS WITHOUT THE EXPRESS WRITTEN APPROVAL OF THE PRESIDENT OF FAIRCHILD SEMICONDUCTOR CORPORATION. As used herein:

1. Life support devices or systems are devices or systems which, (a) are intended for surgical implant into the body, or (b) support or sustain life, and (c) whose failure to perform when properly used in accordance with instructions for use provided in the labeling, can be reasonably expected to result in a significant injury to the user.
2. A critical component in any component of a life support device or system whose failure to perform can be reasonably expected to cause the failure of the life support device or system, or to affect its safety or effectiveness.

[www.fairchildsemi.com](http://www.fairchildsemi.com)