



Chipsmall Limited consists of a professional team with an average of over 10 year of expertise in the distribution of electronic components. Based in Hongkong, we have already established firm and mutual-benefit business relationships with customers from,Europe,America and south Asia,supplying obsolete and hard-to-find components to meet their specific needs.

With the principle of “Quality Parts,Customers Priority,Honest Operation,and Considerate Service”,our business mainly focus on the distribution of electronic components. Line cards we deal with include Microchip,ALPS,ROHM,Xilinx,Pulse,ON,Everlight and Freescale. Main products comprise IC,Modules,Potentiometer,IC Socket,Relay,Connector.Our parts cover such applications as commercial,industrial, and automotives areas.

We are looking forward to setting up business relationship with you and hope to provide you with the best service and solution. Let us make a better world for our industry!



Contact us

Tel: +86-755-8981 8866 Fax: +86-755-8427 6832

Email & Skype: info@chipsmall.com Web: www.chipsmall.com

Address: A1208, Overseas Decoration Building, #122 Zhenhua RD., Futian, Shenzhen, China



MM74HC161 • MM74HC163

Synchronous Binary Counter with Asynchronous Clear • Synchronous Binary Counter with Synchronous Clear

General Description

The MM74HC161 and MM74HC163 synchronous presettable counters utilize advanced silicon-gate CMOS technology and internal look-ahead carry logic for use in high speed counting applications. They offer the high noise immunity and low power consumption inherent to CMOS with speeds similar to low power Schottky TTL. The HC161 and the HC163 are 4 bit binary counters. All flip-flops are clocked simultaneously on the LOW-to-HIGH transition (positive edge) of the CLOCK input waveform.

These counters may be preset using the LOAD input. Pre-setting of all four flip-flops is synchronous to the rising edge of CLOCK. When LOAD is held LOW counting is disabled and the data on the A, B, C, and D inputs is loaded into the counter on the rising edge of CLOCK. If the load input is taken HIGH before the positive edge of CLOCK the count operation will be unaffected.

All of these counters may be cleared by utilizing the CLEAR input. The clear function on the MM74HC163 counter is synchronous to the clock. That is, the counters are cleared on the positive edge of CLOCK while the clear input is held LOW.

The MM74HC161 counter is cleared asynchronously. When the CLEAR is taken LOW the counter is cleared immediately regardless of the CLOCK.

Two active HIGH enable inputs (ENP and ENT) and a RIPLE CARRY (RC) output are provided to enable easy cascading of counters. Both ENABLE inputs must be HIGH to count. The ENT input also enables the RC output. When enabled, the RC outputs a positive pulse when the counter overflows. This pulse is approximately equal in duration to the HIGH level portion of the Q_A output. The RC output is fed to successive cascaded stages to facilitate easy implementation of N-bit counters.

All inputs are protected from damage due to static discharge by diodes to V_{CC} and ground.

Features

- Typical operating frequency: 40 MHz
- Typical propagation delay; clock to Q: 18 ns
- Low quiescent current: 80 μA maximum (74HC Series)
- Low input current: 1 μA maximum
- Wide power supply range: 2–6V

Ordering Code:

Order Number	Package Number	Package Description
MM74HC161M (Note 1)	M16A	16-Lead Small Outline Integrated Circuit (SOIC), JEDEC MS-012, 0.150" Narrow
MM74HC161SJ	M16D	16-Lead Small Outline Package (SOP), EIAJ TYPE II, 5.3mm Wide
MM74HC161MTC (Note 1)	MTC16	16-Lead Thin Shrink Small Outline Package (TSSOP), JEDEC MO-153, 4.4mm Wide
MM74HC161N	N16E	16-Lead Plastic Dual-In-Line Package (PDIP), JEDEC MS-001, 0.300" Wide
MM74HC163M (Note 1)	M16A	16-Lead Small Outline Integrated Circuit (SOIC), JEDEC MS-012, 0.150" Narrow
MM74HC163SJ	M16D	16-Lead Small Outline Package (SOP), EIAJ TYPE II, 5.3mm Wide
MM74HC163N	N16E	16-Lead Plastic Dual-In-Line Package (PDIP), JEDEC MS-001, 0.300" Wide

Note 1: Devices also available in Tape and Reel. Specify by appending the suffix letter "X" to the ordering code.

MM74HC161 • MM74HC163 Synchronous Binary Counter with Asynchronous Clear • Synchronous Binary Counter with Synchronous Clear

Connection Diagram

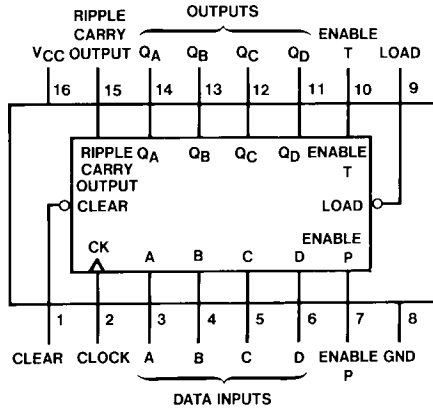

Truth Tables

MM74HC161

CLK	CLR	ENP	ENT	Load	Function
X	L	X	X	X	Clear
X	H	H	L	H	Count & RC disabled
X	H	L	H	H	Count disabled
X	H	L	L	H	Count & RC disabled
↑	H	X	X	L	Load
↑	H	H	H	H	Increment Counter

MM74HC163

CLK	CLR	ENP	ENT	Load	Function
↑	L	X	X	X	Clear
X	H	H	L	H	Count & RC disabled
X	H	L	H	H	Count disabled
X	H	L	L	H	Count & RC disabled
↑	H	X	X	L	Load
↑	H	H	H	H	Increment Counter

H = HIGH Level
 L = LOW Level
 X = Don't Care
 ↑ = LOW-to-HIGH Transition

Logic Diagram

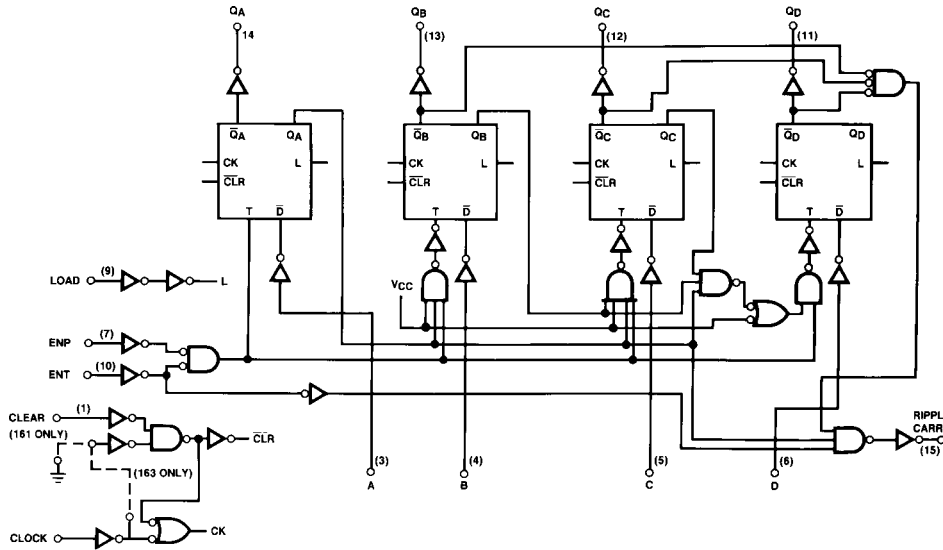

Absolute Maximum Ratings (Note 2)

(Note 3)

Supply Voltage (V_{CC})	-0.5 to +7.0V
DC Input Voltage (V_{IN})	-1.5 to $V_{CC}+1.5V$
DC Output Voltage (V_{OUT})	-0.5 to $V_{CC}+0.5V$
Clamp Diode Current (I_{IK}, I_{OK})	± 20 mA
DC Output Current, per pin (I_{OUT})	± 25 mA
DC V_{CC} or GND Current, per pin (I_{CC})	± 50 mA
Storage Temperature Range (T_{STG})	-65°C to +150°C
Power Dissipation (P_D)	
(Note 4)	600 mW
S.O. Package only	500 mW
Lead Temperature	
(T_L) (Soldering 10 seconds)	260°C

Recommended Operating Conditions

	Min	Max	Units
Supply Voltage (V_{CC})	2	6	V
DC Input or Output Voltage (V_{IN}, V_{OUT})	0	V_{CC}	V
Operating Temperature Range (T_A)	-40	+85	°C
Input Rise or Fall Times (t_r, t_f) $V_{CC} = 2.0V$		1000	ns
$V_{CC} = 4.5V$		500	ns
$V_{CC} = 6.0V$		400	ns

Note 2: Absolute Maximum Ratings are those values beyond which damage to the device may occur.

Note 3: Unless otherwise specified all voltages are referenced to ground.

Note 4: Power Dissipation temperature derating — plastic "N" package: -12 mW/°C from 65°C to 85°C.

DC Electrical Characteristics (Note 5)

Symbol	Parameter	Conditions	V_{CC}	$T_A = 25^\circ C$			$T_A = -40$ to $85^\circ C$	$T_A = -55$ to $125^\circ C$	Units
				Typ	Guaranteed Limits				
V_{IH}	Minimum HIGH Level Input Voltage		2.0V		1.5	1.5	1.5	V	
			4.5V		3.15	3.15	3.15		
			6.0V		4.2	4.2	4.2		
V_{IL}	Maximum LOW Level Input Voltage		2.0V		0.5	0.5	0.5	V	
			4.5V		1.35	1.35	1.35		
			6.0V		1.8	1.8	1.8		
V_{OH}	Minimum HIGH Level Output Voltage	$V_{IN} = V_{IH}$ or V_{IL} $ I_{OUT} \leq 20 \mu A$	2.0V	2.0	1.9	1.9	1.9	V	
			4.5V	4.5	4.4	4.4	4.4		
			6.0V	6.0	5.9	5.9	5.9		
		$V_{IN} = V_{IH}$ or V_{IL} $ I_{OUT} \leq 4.0$ mA $ I_{OUT} \leq 5.2$ mA	4.5V	4.2	3.98	3.84	3.7	V	
			6.0V	5.7	5.48	5.34	5.2		
V_{OL}	Maximum LOW Level Output Voltage	$V_{IN} = V_{IH}$ or V_{IL} $ I_{OUT} \leq 20 \mu A$	2.0V	0	0.1	0.1	0.1	V	
			4.5V	0	0.1	0.1	0.1		
			6.0V	0	0.1	0.1	0.1		
		$V_{IN} = V_{IH}$ or V_{IL} $ I_{OUT} \leq 4.0$ mA $ I_{OUT} \leq 5.2$ mA	4.5V	0.2	0.26	0.33	0.4	V	
			6.0V	0.2	0.26	0.33	0.4		
I_{IN}	Maximum Input Current	$V_{IN} = V_{CC}$ or GND	6.0V		± 0.1	± 1.0	± 1.0	μA	
I_{CC}	Maximum Quiescent Supply Current	$V_{IN} = V_{CC}$ or GND $I_{OUT} = 0 \mu A$	6.0V		8.0	80	160	μA	

Note 5: For a power supply of $5V \pm 10\%$ the worst case output voltages (V_{OH} , and V_{OL}) occur for HC at 4.5V. Thus the 4.5V values should be used when designing with this supply. Worst case V_{IH} and V_{IL} occur at $V_{CC} = 5.5V$ and 4.5V respectively. (The V_{IH} value at 5.5V is 3.85V.) The worst case leakage current (I_{IN} , I_{CC} , and I_{OZ}) occur for CMOS at the higher voltage and so the 6.0V values should be used.

AC Electrical Characteristics $V_{CC} = 5V$, $T_A = 25^\circ C$, $C_L = 15\text{ pF}$, $t_r = t_f = 6\text{ ns}$

Symbol	Parameter	Conditions	Typ	Guaranteed Limit	Units
f_{MAX}	Maximum Operating Frequency		43	30	MHz
t_{PHL} , t_{PLH}	Maximum Propagation Delay, Clock to RC		30	35	ns
t_{PHL} , t_{PLH}	Maximum Propagation Delay, Clock to Q		29	34	ns
t_{PHL} , t_{PLH}	Maximum Propagation Delay, ENT to RC		18	32	ns
t_{PHL}	Maximum Propagation Delay, Clear to Q or RC		27	38	ns
t_{REM}	Minimum Removal Time, Clear to Clock		10	20	ns
t_S	Minimum Set Up Time Clear, Load, Enable or Data to Clock			30	ns
t_H	Minimum Hold Time, Data from Clock			5	ns
t_W	Minimum Pulse Width Clock, Clear, or Load			16	ns

AC Electrical Characteristics $C_L = 50\text{ pF}$, $t_r = t_f = 6\text{ ns}$ (unless otherwise specified)

Symbol	Parameter	Conditions	V_{CC}	$T_A = 25^\circ C$		$T_A = -40\text{ to }85^\circ C$	$T_A = -55\text{ to }125^\circ C$	Units
				Typ	Guaranteed Limits			
f_{MAX}	Maximum Operating Frequency		2.0V	10	5	4	4	MHz
			4.5V	40	27	21	18	
			6.0V	45	32	25	21	
t_{PHL}	Maximum Propagation Delay, Clock to RC		2.0V	100	215	271	320	ns
			4.5V	32	43	54	64	
			6.0V	28	37	46	54	
t_{PLH}	Maximum Propagation Delay, Clock to RC		2.0V	88	175	220	260	ns
			4.5V	18	35	44	52	
			6.0V	15	30	37	44	
t_{PHL}	Maximum Propagation Delay, Clock to Q		2.0V	95	205	258	305	ns
			4.5V	30	41	52	61	
			6.0V	26	35	44	52	
t_{PLH}	Maximum Propagation Delay, Clock to Q		2.0V	85	170	214	253	ns
			4.5V	17	34	43	51	
			6.0V	14	29	36	43	
t_{PHL}	Maximum Propagation Delay, ENT to RC		2.0V	90	195	246	291	ns
			4.5V	28	39	49	58	
			6.0V	24	33	42	49	
t_{PLH}	Maximum Propagation Delay, ENT to RC		2.0V	80	160	202	238	ns
			4.5V	16	32	40	48	
			6.0V	14	27	34	41	
t_{PHL}	Maximum Propagation Delay, Clear to RC		2.0V	100	220	275	325	ns
			4.5V	32	44	55	66	
			6.0V	28	37	47	55	
t_{PHL}	Maximum Propagation Delay, Clear to Q		2.0V	100	210	260	315	ns
			4.5V	32	42	52	63	
			6.0V	28	36	45	54	
t_{REM}	Minimum Removal Time Clear to Clock		2.0V		125	158	186	ns
			4.5V		25	32	37	
			6.0V		21	27	32	
t_S	Minimum Setup Time Clear or Data to Clock		2.0V		150	190	225	ns
			4.5V		30	38	45	
			6.0V		26	32	38	
t_S	Minimum Setup Time Load to Clock		2.0V		135	170	200	ns
			4.5V		27	34	41	
			6.0V		23	29	35	

AC Electrical Characteristics (Continued)

Symbol	Parameter	Conditions	V _{CC}	T _A = 25°C			T _A = -55 to 125°C	Units
				Typ	Guaranteed Limits			
t _S	Minimum Setup Time Enable to Clock		2.0V		175	220	260	ns
			4.5V		35	44	52	
			6.0V		30	37	44	
t _H	Minimum Hold Time Data from Clock		2.0V		50	63	75	ns
			4.5V		10	13	15	
			6.0V		9	11	13	
t _H	Minimum Hold Time Enable, Load or Clear to Clock		2.0V		0	0	0	ns
			4.5V		0	0	0	
			6.0V		0	0	0	
t _W	Minimum Pulse Width Clock, Clear, or Load		2.0V		80	100	120	ns
			4.5V		16	20	24	
			6.0V		14	17	20	
t _{TLH} , t _{THL}	Maximum Output Rise and Fall Time		2.0V	40	75	95	110	ns
			4.5V	8	15	19	22	
			6.0V	7	13	16	19	
t _r , t _f	Maximum Input Rise and Fall Time		2.0V		1000	1000	1000	ns
			4.5V	500	500	500	500	
			6.0V		400	400	400	
C _{PD}	Power Dissipation Capacitance (Note 6)	(per package)		90				pF
C _{IN}	Maximum Input Capacitance			5	10	10	10	pF

Note 6: C_{PD} determines the no load dynamic power consumption, P_D = C_{PD} V_{CC}² f + I_{CC} V_{CC}, and the no load dynamic current consumption, I_S = C_{PD} V_{CC} f + I_{CC}.

Logic Waveforms

Synchronous Binary Counters Typical Clear, Preset, Count and Inhibit Sequences

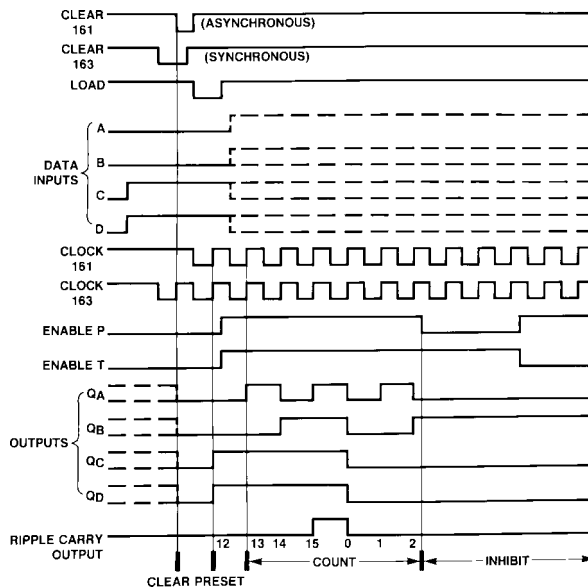

Sequence: (1) Clear outputs to zero (2) Preset to binary twelve (3) Count to thirteen, fourteen, fifteen, zero, one and two (4) Inhibit

Physical Dimensions inches (millimeters) unless otherwise noted

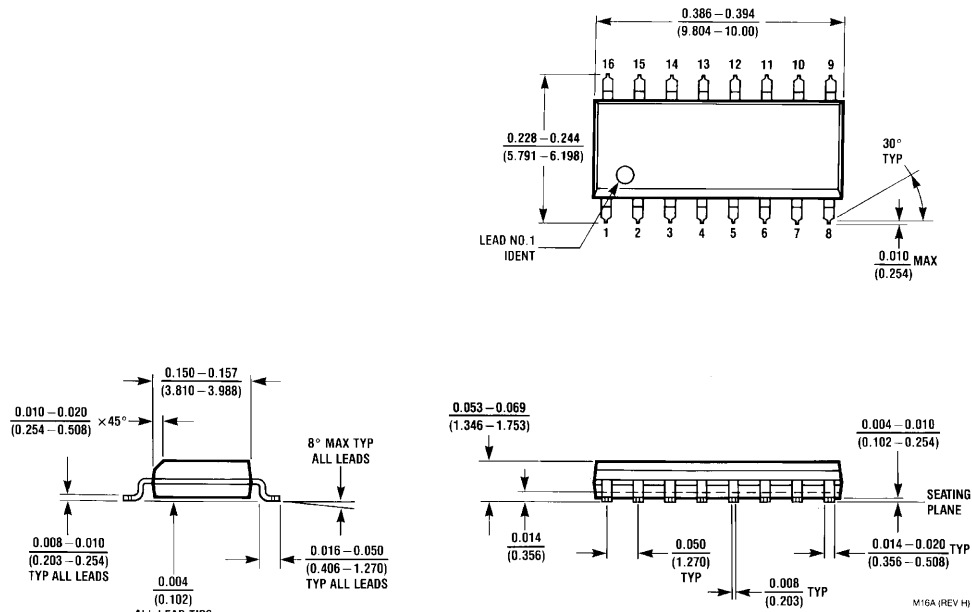

16-Lead Small Outline Integrated Circuit (SOIC), JEDEC MS-012, 0.150" Narrow Package Number M16A

Physical Dimensions inches (millimeters) unless otherwise noted (Continued)

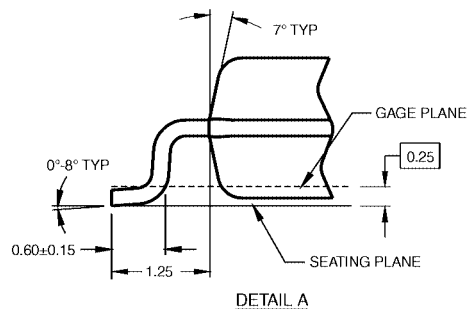
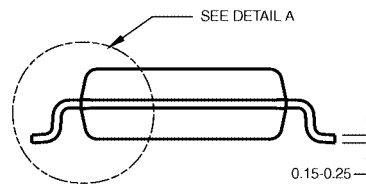
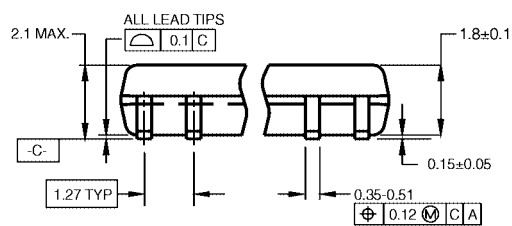
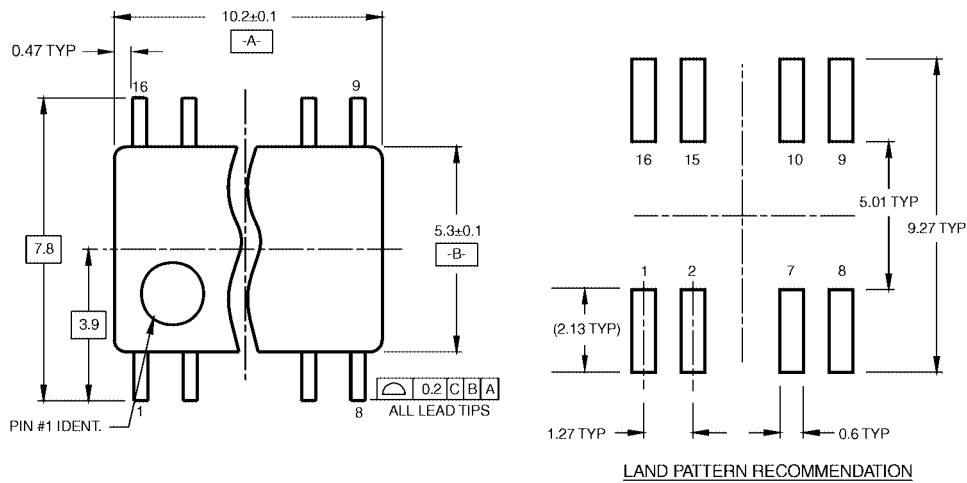

- NOTES:
- A. CONFORMS TO EIAJ EDR-7320 REGISTRATION, ESTABLISHED IN DECEMBER, 1998.
 - B. DIMENSIONS ARE IN MILLIMETERS.
 - C. DIMENSIONS ARE EXCLUSIVE OF BURRS, MOLD FLASH, AND TIE BAR EXTRUSIONS.

M16DRevB1

**16-Lead Small Outline Package (SOP), EIAJ TYPE II, 5.3mm Wide
Package Number M16D**

Physical Dimensions inches (millimeters) unless otherwise noted (Continued)

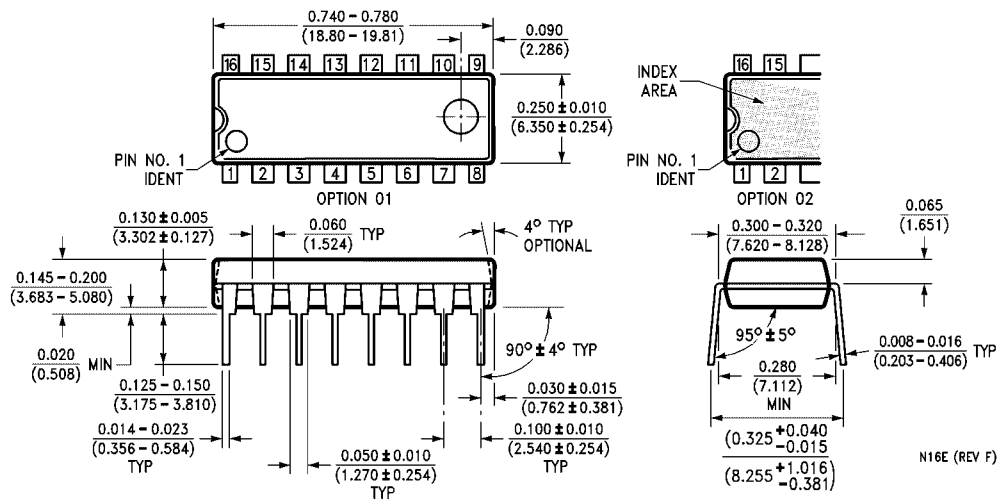

16-Lead Plastic Dual-In-Line Package (PDIP), JEDEC MS-001, 0.300" Wide Package Number N16E

Fairchild does not assume any responsibility for use of any circuitry described, no circuit patent licenses are implied and Fairchild reserves the right at any time without notice to change said circuitry and specifications.

LIFE SUPPORT POLICY

FAIRCHILD'S PRODUCTS ARE NOT AUTHORIZED FOR USE AS CRITICAL COMPONENTS IN LIFE SUPPORT DEVICES OR SYSTEMS WITHOUT THE EXPRESS WRITTEN APPROVAL OF THE PRESIDENT OF FAIRCHILD SEMICONDUCTOR CORPORATION. As used herein:

1. Life support devices or systems are devices or systems which, (a) are intended for surgical implant into the body, or (b) support or sustain life, and (c) whose failure to perform when properly used in accordance with instructions for use provided in the labeling, can be reasonably expected to result in a significant injury to the user.
2. A critical component in any component of a life support device or system whose failure to perform can be reasonably expected to cause the failure of the life support device or system, or to affect its safety or effectiveness.

www.fairchildsemi.com