



Chipsmall Limited consists of a professional team with an average of over 10 year of expertise in the distribution of electronic components. Based in Hongkong, we have already established firm and mutual-benefit business relationships with customers from,Europe,America and south Asia,supplying obsolete and hard-to-find components to meet their specific needs.

With the principle of “Quality Parts,Customers Priority,Honest Operation,and Considerate Service”,our business mainly focus on the distribution of electronic components. Line cards we deal with include Microchip,ALPS,ROHM,Xilinx,Pulse,ON,Everlight and Freescale. Main products comprise IC,Modules,Potentiometer,IC Socket,Relay,Connector.Our parts cover such applications as commercial,industrial, and automotives areas.

We are looking forward to setting up business relationship with you and hope to provide you with the best service and solution. Let us make a better world for our industry!



Contact us

Tel: +86-755-8981 8866 Fax: +86-755-8427 6832

Email & Skype: info@chipsmall.com Web: www.chipsmall.com

Address: A1208, Overseas Decoration Building, #122 Zhenhua RD., Futian, Shenzhen, China



DESCRIPTION

These low capacitance diode arrays are multiple, discrete, isolated junctions fabricated by a planar process and mounted in a 14-pin package for use as steering diodes protecting up to eight I/O ports from negative ESD, EFT, or surge by directing them to ground (pin 14)*. They may also be used in fast switching core-driver applications. This includes computers and peripheral equipment such as magnetic cores, thin-film memories, plated-wire memories, etc., as well as decoding or encoding applications. These arrays offer many advantages of integrated circuits such as high-density packaging and improved reliability. This is a result of fewer pick and place operations, smaller footprint, smaller weight, and elimination of various discrete packages that may not be as user friendly in PC board mounting. They are available with either Tin-Lead plating terminations or as RoHS Compliant with annealed matte-Tin finish by adding an "e3" suffix to the part number.

*See MMAD1105(e3) for directing positive transients to positive side of the power supply line.

APPEARANCE

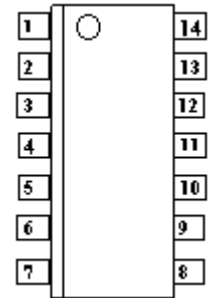

Top Viewing Pin Layout

IMPORTANT: For the most current data, consult MICROSEMI's website: <http://www.microsemi.com>

FEATURES

- 8 Diode Array
- Molded 14-Pin SOIC Package
- UL 94V-0 Flammability Classification
- Low Capacitance 1.5 pF per diode
- Switching speeds less than 5 ns
- RoHS Compliant devices available by adding "e3" suffix
- IEC 61000-4 compatible
 - 61000-4-2 (ESD): Air 15kV, contact – 8 kV
 - 61000-4-4 (EFT): 40A – 5/50 ns
 - 61000-4-5 (surge): 12A, 8/20 μs

APPLICATIONS / BENEFITS

- Low capacitance steering diode protection for high frequency data lines
- RS-232 & RS-422 Interface Networks
- Ethernet: 10 Base T
- Computer I / O Ports
- LAN
- Switching Core Drivers

MAXIMUM RATINGS

- Operating Temperature: -55°C to +150°C
- Storage Temperature: -55°C to +150°C
- Forward Surge Current: 2 Amps (8.3 ms)
12 Amps (8/20 μs)
- Continuous Forward Current: 400 mA (one diode)
- Power Dissipation (P_D): 1500 mW (total)
- Solder Temperatures: 260°C for 10 s (maximum)

MECHANICAL AND PACKAGING

- CASE: Void-free transfer molded thermosetting epoxy body meeting UL94V-0 flammability classification
- TERMINALS: Tin-Lead or RoHS Compliant annealed matte-Tin plating solderable per MIL-STD-750 method 2026
- MARKING: MSC logo, MMAD1106 or MMAD1106e3 and date code. Pin #1 is to the left of the dot or indent on top of package
- WEIGHT: 0.127 grams (approximate)
- Tape & Reel packaging: 2500 pcs (STANDARD)
- Carrier tube packaging: 55 pcs

ELECTRICAL CHARACTERISTICS PER LINE @25°C Unless otherwise specified

PART NUMBER	BREAKDOWN VOLTAGE V _{BR} @ I _{BR} = 100μA	WORKING PEAK REVERSE VOLTAGE V _{RWM}	LEAKAGE CURRENT I _R T _A = 25°C		LEAKAGE CURRENT I _R T _A = 150°C		CAPACITANCE C @ 0 V	REVERSE RECOVERY TIME t _r	FORWARD VOLTAGE V _F I _F = 10 mA	FORWARD VOLTAGE V _F I _F = 100 mA
	V	V	MAX	@V _R	MAX	@V _R	pF	ns	V	V
	MIN	MAX	MAX		MAX		TYP	MAX	MAX	MAX
MMAD1106 MMAD1106e3	90	75	0.200	20	300	20	1.5	5.0	1.00	1.20

SYMBOLS & DEFINITIONS

Symbol	Definition
V_{BR}	Minimum Breakdown Voltage: The minimum voltage the device will exhibit at a specified current.
V_{RWM}	Working Peak Reverse Voltage: The maximum peak voltage that can be applied over the operating temperature range.
V_F	Maximum Forward Voltage: The maximum forward voltage the device will exhibit at a specified current.
I_R	Maximum Leakage Current: The maximum leakage current that will flow at the specified voltage and temperature.
C	Capacitance: The capacitance of the TVS as defined @ 0 volts at a frequency of 1 MHz and stated in picofarads.

OUTLINE AND CIRCUIT

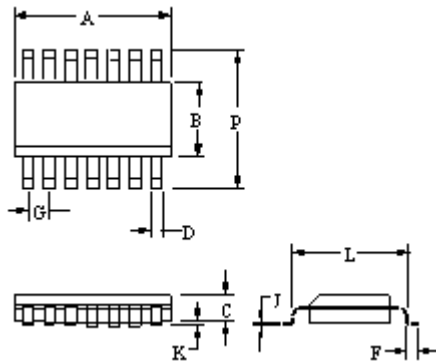

DIM	INCHES		MILLIMETERS	
	MIN	MAX	MIN	MAX
A	0.336	0.344	8.53	8.74
B	0.150	0.158	3.81	4.01
C	0.053	0.069	1.35	1.75
D	0.011	0.021	0.28	0.53
F	0.016	0.050	0.41	1.27
G	0.050 BSC		01.27 BSC	
J	0.006	0.010	0.15	0.25
K	0.004	0.008	0.10	0.20
L	0.189	0.206	4.80	5.23
P	0.228	0.244	5.79	6.19

OUTLINE

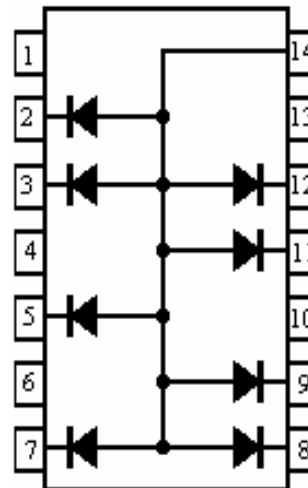

CIRCUIT CONFIGURATION

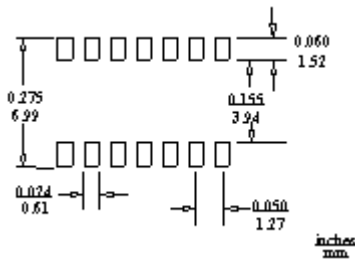

PAD LAYOUT