



Chipsmall Limited consists of a professional team with an average of over 10 year of expertise in the distribution of electronic components. Based in Hongkong, we have already established firm and mutual-benefit business relationships with customers from,Europe,America and south Asia,supplying obsolete and hard-to-find components to meet their specific needs.

With the principle of “Quality Parts,Customers Priority,Honest Operation,and Considerate Service”,our business mainly focus on the distribution of electronic components. Line cards we deal with include Microchip,ALPS,ROHM,Xilinx,Pulse,ON,Everlight and Freescale. Main products comprise IC,Modules,Potentiometer,IC Socket,Relay,Connector.Our parts cover such applications as commercial,industrial, and automotives areas.

We are looking forward to setting up business relationship with you and hope to provide you with the best service and solution. Let us make a better world for our industry!



Contact us

Tel: +86-755-8981 8866 Fax: +86-755-8427 6832

Email & Skype: info@chipsmall.com Web: www.chipsmall.com

Address: A1208, Overseas Decoration Building, #122 Zhenhua RD., Futian, Shenzhen, China



DO NOT SCALE FROM THIS PRINT

N

TABLE 1			
ITEM	COMPONENT	-H	-HN
1	SUB ASSEMBLY	SUB-MMCX-P-C-F-ST-CA1	SUB-MMCX-P-C-FN-ST-CA1
2	PIN	MMCX-PIN-001-H	MMCX-PIN-001-H
3	OUTER FERRULE	MCX-FER-001-F	MCX-FER-001-N

GENDER
-P: PLUG

TYPE
-C: CABLE

TERMINATION
-CA1: CABLE
(RG174 OR RG316)

ORIENTATION
-ST: STRAIGHT

N PLATING SPECIFICATION
 -H: 30µ" GOLD CENTER CONTACT,
 3µ" GOLD OUTER CONTACT
 -HN: 30µ" GOLD CENTER CONTACT,
 100µ" NICKEL OUTER CONTACT
 (SEE TABLE 1)

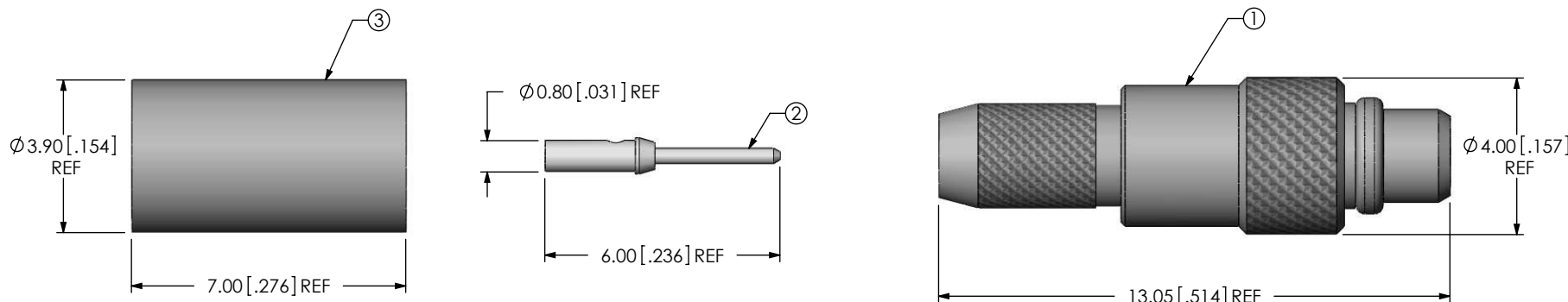



FIG 1
MMCX-P-C-XX-ST-CA1-MKT SHOWN

NOTES:

1. C REPRESENTS A CRITICAL DIMENSION.
2. PUSHOUT FORCE FOR CENTER CONTACT: 11.12 N [2.5 LB] MIN.
3. NOTE DELETED.
4. NOTE DELETED.
5. PRODUCT TO BE PACKAGED PER PACKAGING STANDARD CO-HD-WI-3040-M.
6. NOTE DELETED.
7. NOTE DELETED.
8. NOTE DELETED.

F:\DWG\MISC\MKTG\MMCX-P-C-XX-ST-CA1-MKT.SLDDRW

UNLESS OTHERWISE SPECIFIED, DIMENSIONS ARE IN MILLIMETERS [INCHES]. TOLERANCES ARE: DECIMALS ANGLES .X: ±0.3 [.01] 5° .XX: ±0.13 [.005] .XXX: ±0.051 [.0020]	PROPRIETARY NOTE THIS DOCUMENT CONTAINS INFORMATION CONFIDENTIAL AND PROPRIETARY TO SAMTEC, INC. AND SHALL NOT BE REPRODUCED OR TRANSFERRED TO OTHER DOCUMENTS OR DISCLOSED TO OTHERS OR USED FOR ANY PURPOSE OTHER THAN THAT WHICH IT WAS OBTAINED WITHOUT THE EXPRESSED WRITTEN CONSENT OF SAMTEC, INC.		
		520 PARK EAST BLVD, NEW ALBANY, IN 47150 PHONE: 812-944-6733 FAX: 812-948-5047 e-Mail: info@SAMTEC.com code: 55322	
MATERIAL: DO NOT SCALE DRAWING SHEET SCALE: 4:1 SHELL, FERRULE: BRASS CONTACT: BRASS DIELECTRIC: PTFE		DESCRIPTION: MMCX STR CABLE PLUG, RG174 & RG316- 50 OHM DWG. NO. MMCX-P-C-XX-ST-CA1	
		BY: R MUSSER 02/06/2008	SHEET 1 OF 2

REVISION N

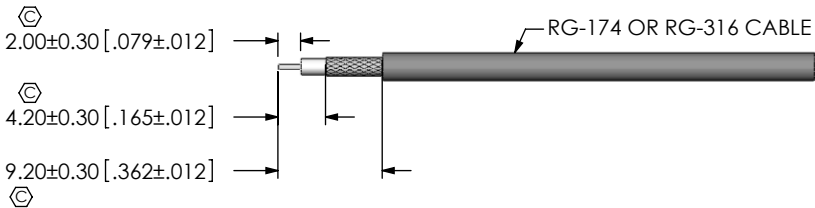

IN-PROCESS 1
STRIP AND TIN INNER CONDUCTOR

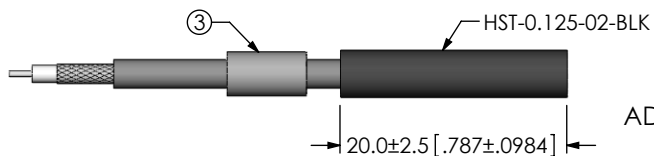

IN-PROCESS 2
ADD HEAT SHRINK TUBE AND FERRULE



IN-PROCESS 3
SOLDER SIGNAL PIN

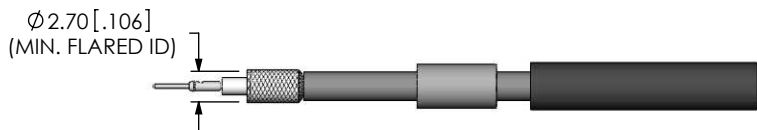

IN-PROCESS 4
FLARE SHIELD

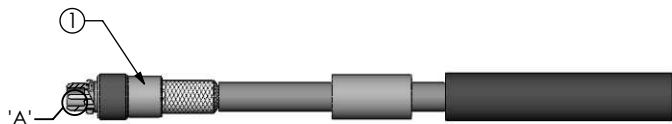

IN-PROCESS 5
ADD SUB-ASSEMBLY

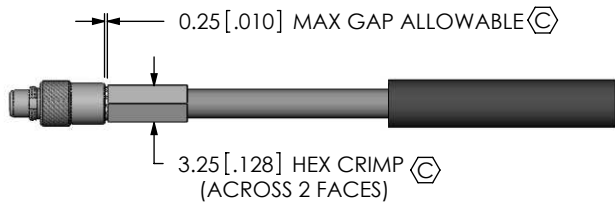

IN-PROCESS 6
CRIMP FERRULE
(USE RF CRIMP HAND TOOL
CAT-HT-126667-21 OR EQUIVALENT)

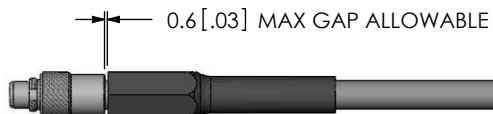

IN-PROCESS 7
APPLY HEAT SHRINK TUBING

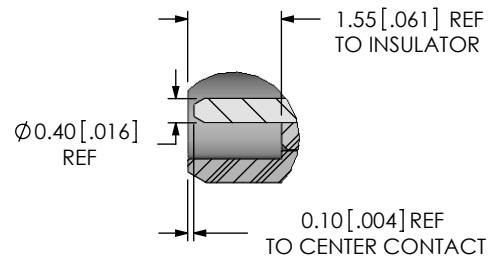

DETAIL 'A'
SCALE 8:1

CRITICAL DIMENSION INSPECTION INSTRUCTION TABLE	
ASSEMBLY OPERATION	IN-PROCESS INSPECTION
STRIP AND TIN INNER CONDUCTOR	C101, C102, C103
SOLDER SIGNAL PIN	C104
CRIMP FERRULE	C105, C106

PROPRIETARY NOTE

THIS DOCUMENT CONTAINS INFORMATION CONFIDENTIAL AND PROPRIETARY TO SAMTEC, INC. AND SHALL NOT BE REPRODUCED OR TRANSFERRED TO OTHER DOCUMENTS OR DISCLOSED TO OTHERS OR USED FOR ANY PURPOSE OTHER THAN THAT WHICH IT WAS OBTAINED WITHOUT THE EXPRESSED WRITTEN CONSENT OF SAMTEC, INC.

DO NOT SCALE DRAWING

SHEET SCALE: 1:0.666667



520 PARK EAST BLVD, NEW ALBANY, IN 47150
PHONE: 812-944-6733 FAX: 812-948-5047
e-Mail: info@SAMTEC.com code: 55322

DESCRIPTION:
MMCX STR CABLE PLUG, RG174 & RG316- 50 OHM

DWG. NO.
MMCX-P-C-XX-ST-CA1

BY: R MUSSER 02/06/2008 SHEET 2 OF 2