



Chipsmall Limited consists of a professional team with an average of over 10 year of expertise in the distribution of electronic components. Based in Hongkong, we have already established firm and mutual-benefit business relationships with customers from,Europe,America and south Asia,supplying obsolete and hard-to-find components to meet their specific needs.

With the principle of "Quality Parts,Customers Priority,Honest Operation,and Considerate Service",our business mainly focus on the distribution of electronic components. Line cards we deal with include Microchip,ALPS,ROHM,Xilinx,Pulse,ON,Everlight and Freescale. Main products comprise IC,Modules,Potentiometer,IC Socket,Relay,Connector.Our parts cover such applications as commercial,industrial, and automotives areas.

We are looking forward to setting up business relationship with you and hope to provide you with the best service and solution. Let us make a better world for our industry!



Contact us

Tel: +86-755-8981 8866 Fax: +86-755-8427 6832

Email & Skype: info@chipsmall.com Web: www.chipsmall.com

Address: A1208, Overseas Decoration Building, #122 Zhenhua RD., Futian, Shenzhen, China



DESIGNED & DIMENSIONED
IN MILLIMETERS [INCHES]

DO NOT
SCALE FROM
THIS PRINT

TABLE 1			
ITEM	COMPONENT	-H	-HN
1	SUB ASSEMBLY	SUB-MMCX-P-C-F-ST-CA2	SUB-MMCX-P-C-FN-ST-CA2
2	PIN	MMCX-PIN-002-H	
3	OUTER FERRULE	MCX-FER-005-F	MCX-FER-005-N

MMCX-P-C-XX-ST-CA2

GENDER
-P: PLUG

TERMINATION
-CA2: (RG 178 CABLE)

TYPE
-C: CABLE

ORIENTATION
-ST: STRAIGHT

PLATING SPECIFICATION

-H: 30µ" GOLD CENTER CONTACT,
3µ" GOLD OUTER CONTACT
-HN: 30µ" GOLD CENTER CONTACT,
100µ" NICKEL OUTER CONTACT
(SEE TABLE 1)

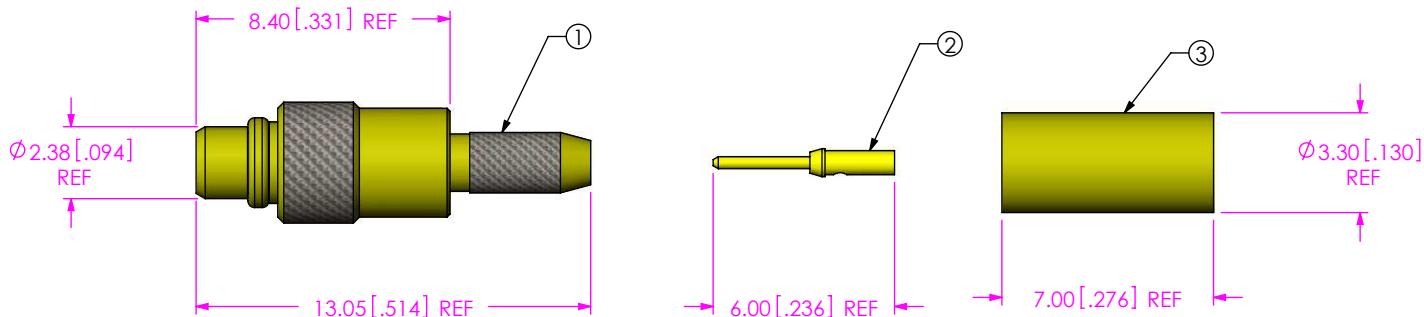

NOTES:

1. NOTE DELETED.
2. NOTE DELETED.
3. NOTE DELETED.
4. NOTE DELETED.
5. PRODUCT TO BE PACKAGED PER PACKAGING STANDARD CO-RF-WI-3040-M.
6. NOTE DELETED.
7. NOTE DELETED.
8. NOTE DELETED.

F:\DWG\MISC\MKTG\MMCX-P-C-XX-ST-CA2-MKT.SLDDRW

UNLESS OTHERWISE SPECIFIED,
DIMENSIONS ARE IN
MILLIMETERS [INCHES].
TOLERANCES ARE:
DECIMALS ANGLES
.X: ±0.3 [.01] 5°
.XX: ±0.13 [.005]
.XXX: ±0.051 [.0020]

PROPRIETARY NOTE
THIS DOCUMENT CONTAINS CONFIDENTIAL AND
PROPRIETARY INFORMATION AND ALL DESIGN,
MANUFACTURING, REPRODUCTION, USE, PATENT RIGHTS
AND SALES RIGHTS ARE EXPRESSLY RESERVED BY SAMTEC,
INC. THIS DOCUMENT SHALL NOT BE DISCLOSED, IN WHOLE
OR PART, TO ANY UNAUTHORIZED PERSON OR ENTITY NOR
REPRODUCED, TRANSFERRED OR INCORPORATED IN ANY
OTHER PROJECT IN ANY MANNER WITHOUT THE EXPRESS
WRITTEN CONSENT OF SAMTEC, INC.

MATERIAL: DO NOT SCALE DRAWING SHEET SCALE: 4:1

SHELL, FERRULE: BRASS
CONTACT: BRASS
DIELECTRIC: PTFE



520 PARK EAST BLVD, NEW ALBANY, IN 47150
PHONE: 812-944-6733 FAX: 812-948-5047
e-Mail: info@SAMTEC.com code: 55322

DESCRIPTION:
MMCX STR CABLE PLUG, RG178- 50 OHM

DWG. NO.
MMCX-P-C-XX-ST-CA2

BY: R MUSSER 02/06/2008 SHEET 1 OF 2

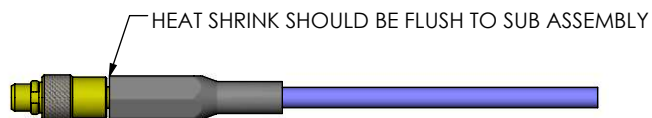
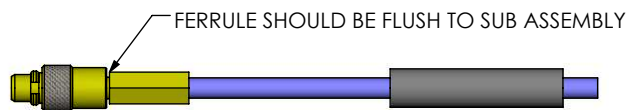
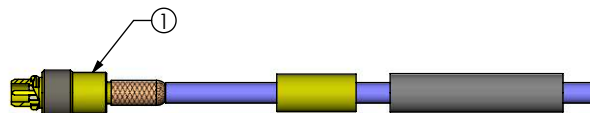
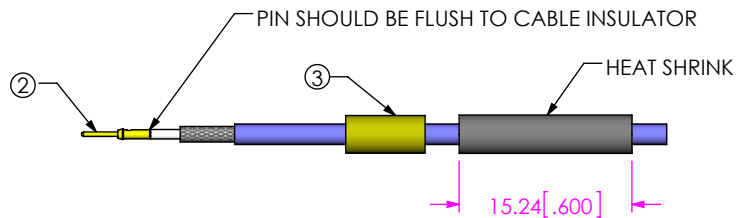
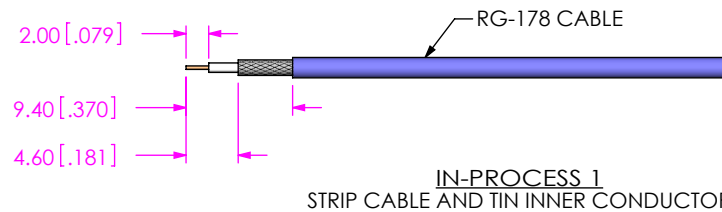

PROPRIETARY NOTE
THIS DOCUMENT CONTAINS CONFIDENTIAL AND PROPRIETARY INFORMATION AND ALL DESIGN, MANUFACTURING, REPRODUCTION, USE, PATENT RIGHTS AND SALES RIGHTS ARE EXPRESSLY RESERVED BY SAMTEC, INC. THIS DOCUMENT SHALL NOT BE DISCLOSED, IN WHOLE OR PART, TO ANY UNAUTHORIZED PERSON OR ENTITY NOR REPRODUCED, TRANSFERRED OR INCORPORATED IN ANY OTHER PROJECT IN ANY MANNER WITHOUT THE EXPRESS WRITTEN CONSENT OF SAMTEC, INC.

DO NOT SCALE DRAWING

SHEET SCALE: 1:0.666667



520 PARK EAST BLVD, NEW ALBANY, IN 47150
PHONE: 812-944-6733 FAX: 812-948-5047
e-Mail: info@SAMTEC.com code: 55322

DESCRIPTION:
MMCX STR CABLE PLUG, RG178- 50 OHM

DWG. NO.
MMCX-P-C-XX-ST-CA2

BY: R MUSSER 02/06/2008 SHEET 2 OF 2